

DESKAR

РИНКОМ



Содержание

О компании	4
Техническая информация	6
Твердосплавные пластины	11
Концевые фрезы	107
Державки	117
Расточные державки	155
Державки для обработки резьб	185
Канавочные резцы	193
Твердосплавные расточные минирезцы	215
Корпусные сверла	227



О компании

Lifeng является поставщиком высококачественного инструмента для оборудования с ЧПУ в Китае. Ловкий, агрессивный и парящий - это индивидуальность орла, его дух и сила.

Огромная территория Китая представляет собой отличный рынок и бесконечные возможности для бизнеса. Орел взмывает к небу, расправляет свои крылья и перед его глазами простирается необъятная земля.

Орел обладает духом стремления к новым высотам. В его основе — развитие технологий и инновации, предприимчивость в выборе новых целей, стремление к совершенству.

Lifeng подобен священному тотему, лежащему в основе предприятия. Он — ярко-красный флаг, развевающийся в сердце каждого сотрудника. Он — сила сотрудников Lifeng, бурлящая в их крови, вдохновляющая на развитие и стремление к мечте о решимости развивать бизнес и служить стране.



Производственная мощность

В распоряжении компании несколько современных производственных линий: по изготовлению осевого твердосплавного инструмента, токарных станков, покрытий PVD и CVD.

Маркетинговая и дилерская сеть

Офисы и представительства компании распространены по всей стране. Качество продукции получило высокую оценку клиентов и экспортируется по всему миру.

Тенденции к развитию

Понимание и осознание изменяющегося мира являются ключевыми элементами успеха в бизнесе. На стратегическом уровне планирования мы постоянно занимаемся оценкой рисков и прорабатываем пути решения потенциальных проблем.

Мощное предприятие

Компания Lifeng Precision Tools (Zhejiang) Co., Ltd. расположена в провинции Чжэцзян, городе Вэньлин, промышленном парке Цинъю, у подножия горы Яндан, национального живописного места уровня 5А.

Описание технических параметров режущего инструмента

Точение

Название параметра	Обозначение	Единица измерения
Скорость резания	V_c	м/мин
Подача на оборот	f	мм/об
Глубина резания	a_p	мм
Функциональная ширина	W	мм
Диаметр обрабатываемой детали	$\varnothing D$	мм
Мощность резания	P_c	кВт
Удельное сопротивление резанию	k_c	МПа
Теоретическая шероховатость поверхности	h	мкм
Радиус скругления режущей кромки	r_e	мм
Скорость вращения	n	мин ⁻¹

Фрезерование

Название параметра	Обозначение	Единица измерения
Скорость резания	V_c	м/мин
Минутная подача	V_f	мм/мин
Подача на зуб	f_z	мм/зуб
Подача на оборот	f	мм/об
Число зубьев	z	-
Глубина резания	a_p	мм
Ширина резания	a_e	мм
Циклическая подача	p_f	мм
Мощность резания	P_c	кВт
Удельное сопротивление резанию	k_c	МПа
Скорость съема материала	Q	см ³ /мин
Частота вращения	n	мин ⁻¹

Обработка отверстий

Название параметра	Обозначение	Единица измерения
Скорость резания	V_c	м/мин
Подача на оборот	f	мм/об
Минутная подача	V_f	мм/мин
Диаметр	$\varnothing D_c$	мм
Мощность	P_c	кВт
Крутящий момент	M_e	Н*м
Тяга	T_c	Н
Удельное сопротивление резанию	k_c	МПа
Глубина обработки отверстий	H	мм
Частота вращения	n	мин ⁻¹

Характеристики токарного инструмента

Резец токарный проходной

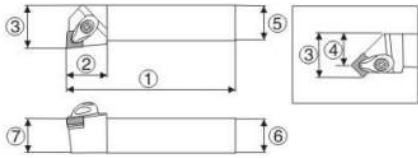

1. Общая длина
2. Функциональная длина
3. Функциональная ширина
4. Минимальный диаметр отверстия
5. Ширина державки
6. Высота державки
7. Функциональная высота

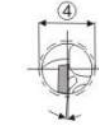

- L1**
L2
f
ØDm
b
h
h1

Резец токарный расточной

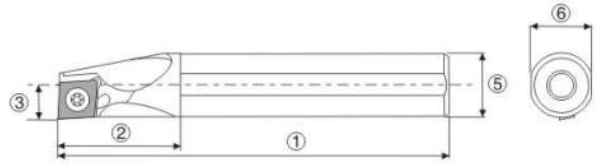

1. Общая длина
2. Функциональная длина
3. Функциональная ширина
4. Минимальный диаметр отверстия
5. Ширина державки
6. Высота державки

- L1**
L2
f
ØDm
b
h

Резец канавочный отрезной

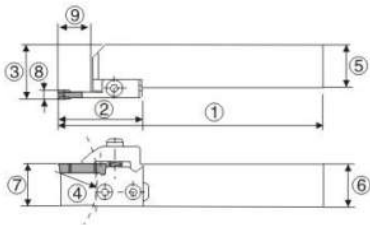

1. Общая длина
2. Функциональная длина
3. Функциональная ширина
4. Минимальный диаметр отверстия
5. Ширина державки
6. Высота державки
7. Функциональная высота
8. Ширина пластины
9. Максимальная глубина резания

- L1**
L2
f
ØDm
b
h
h1
W
ar

Резец токарный канавочный для внутренней обработки

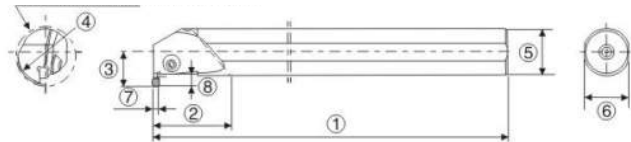

1. Общая длина
2. Функциональная длина
3. Функциональная ширина
4. Минимальный диаметр отверстия
5. Ширина державки
6. Высота державки
7. Функциональная высота
8. Ширина пластины

- L1**
L2
f
ØDm
b
h
h1
W

Резец канавочный для наружной обработки

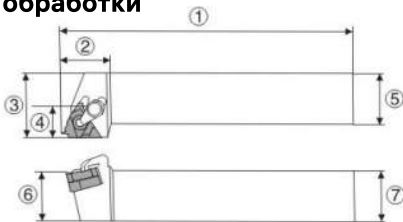

1. Общая длина
2. Функциональная длина
3. Функциональная ширина
4. Минимальный диаметр отверстия
5. Ширина державки
6. Высота державки
7. Функциональная высота

- L1**
L2
f
-
b
h
h1

Резец для токарной обработки внутренней резьбы

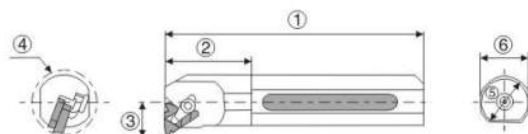

1. Общая длина
2. Функциональная длина
3. Функциональная ширина
4. Минимальный диаметр отверстия
5. Ширина державки
6. Высота державки

- L1**
L2
f
ØDm
b
h

Геометрические параметры фрез

Торцевая фреза

1. Высота лезвия
2. Наружный диаметр
3. Максимальный наружный диаметр
4. Максимальная глубина резания
5. Диаметр отверстия
6. Ширина шпоночной канавки на торце
7. Глубина шпоночной канавки на торце
8. Высота отверстия
9. Диаметр рукава
10. Основной угол наклона
11. Диаметр винтового седла
12. Диаметр резьбового отверстия
13. Высота резьбового отверстия

Lf
 $\varnothing Dc$
 $\varnothing D1$
 $\varnothing Dm$
 ap
 d
 a
 b
 l
 $\varnothing Db$
 k
 $\varnothing d1$
 $\varnothing d2$
 $l1$

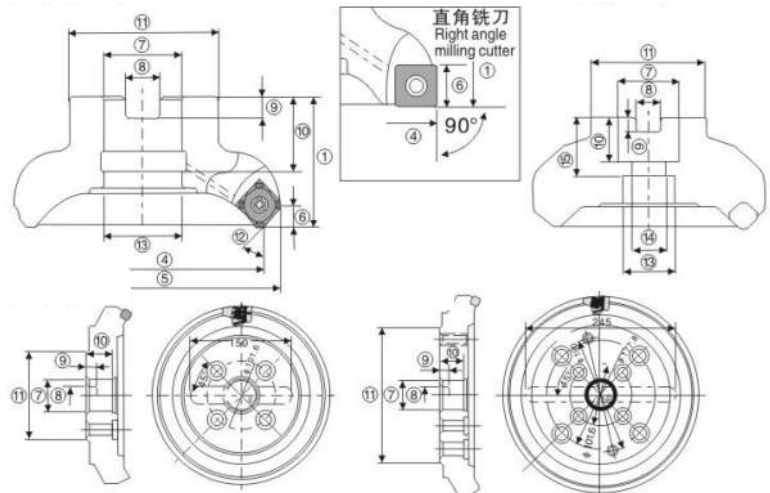

Торцевая фреза с прямым зубом

1. Общая длина корпуса
2. Длина хвостовика
3. Высота рабочей части корпуса
4. Максимальный диаметр резания
5. Диаметр резания
6. Диаметр соединения
7. Основной угол наклона

L
 l_s
 L_f
 $\varnothing Dc$
 $\varnothing D1$
 ap
 $\varnothing Ds$
 K

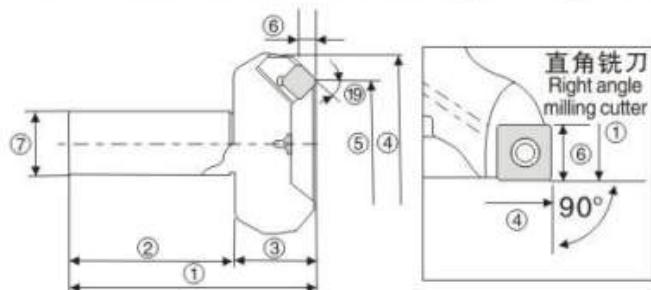

Концевая фреза

1. Общая длина
2. Длина хвостовика
3. Длина рабочей части
4. Высота стружечной канавки
5. Длина режущей стали
6. Радиус сферы
7. Радиус дуги режущей кромки
8. Наружный диаметр
9. Диаметр хвостовика
10. Угол конуса рабочей части
11. Угол конуса тела фрезы
12. Максимальный наружный диаметр
13. Угол интерференции
14. Угол спирали

L
 l_s
 l_2
 l_1
 l
 R
 r
 $\varnothing Dc$
 $\varnothing Ds$
 θn
 θc
 $\varnothing D1$
 θk
 λ

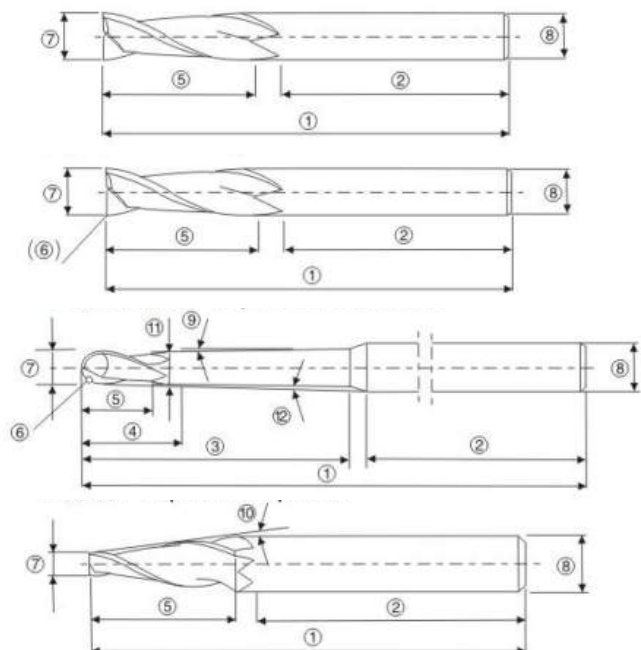

Геометрические параметры фрез

Дисковая фреза для отрезания и обработки канавок

1. Наружный диаметр
2. Внутренний диаметр
3. Диаметр режущей части
4. Диаметр хвостовика
5. Длина хвостовика
6. Угол
7. Радиус окружности наконечника
8. Ширина шпоночной канавки
9. Глубина шпоночной канавки
10. Число зубьев

$\varnothing D_c$
 $\varnothing d$
 l
 $\varnothing D_b$
 T
 α
 R
 a
 b
 z

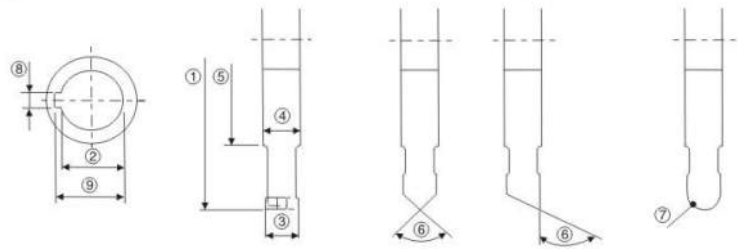

Геометрические параметры сверл

Цилиндрическое сверло

1. Общая длина
2. Длина режущей части
3. Длина хвостовика
4. Диаметр
5. Диаметр хвостовика
6. Высота режущей части

L
 l
 l_s
 $\varnothing D_c$
 $\varnothing D_s$
 L_p

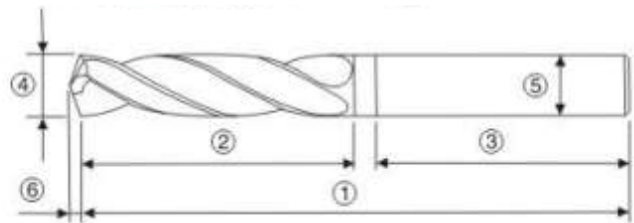

Ступенчатое сверло

1. Общая длина
2. Длина режущей части
3. Длина хвостовика
4. Диаметр
5. Диаметр хвостовика
6. Высота режущей части
7. Диаметр второй ступени
8. Длина первой ступени

L
 l
 l_s
 $\varnothing D_c$
 $\varnothing D_s$
 L_p
 $\varnothing D_{c2}$
 l_1

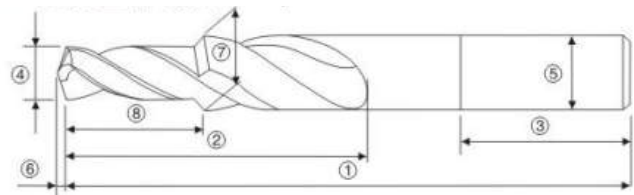

Твердосплавные пластины



Геометрические параметры токарных пластин

1 форма пластины	2 задний угол	3 класс точности	4 конструктивные особенности	5 размер																																																																																																																																																																																																
Шестигранная H - 120° Восьмигранная O - 135° Пятигранная P - 108° Круглая R Квадратная S - 90° Треугольная T - 60° Ромбовидная C - 80° D - 55° M - 86° E - 75° V - 35° Тригональная W - 80° Прямоугольная L - 90° A - 85° B - 82° K - 55°	A 3° B 5° C 7° D 15° E 20° F 25° G 30° N 0° P 11° O указано для других задних углов, требующих описания		N R F A M G W T Q U B H C J X специальная конструкция	<table border="1"> <thead> <tr> <th>D, мм</th> <th>C</th> <th>D</th> <th>R</th> <th>S</th> <th>T</th> <th>V</th> <th>W</th> </tr> </thead> <tbody> <tr> <td>3,97</td> <td>S4</td> <td>04</td> <td>03</td> <td>03</td> <td>06</td> <td>-</td> <td>-</td> </tr> <tr> <td>4,76</td> <td>04</td> <td>05</td> <td>04</td> <td>03</td> <td>08</td> <td>08</td> <td>S3</td> </tr> <tr> <td>5,56</td> <td>05</td> <td>06</td> <td>05</td> <td>05</td> <td>09</td> <td>09</td> <td>03</td> </tr> <tr> <td>6,00</td> <td>-</td> <td>-</td> <td>06</td> <td>-</td> <td>-</td> <td>-</td> <td>-</td> </tr> <tr> <td>6,35</td> <td>06</td> <td>07</td> <td>06</td> <td>06</td> <td>11</td> <td>11</td> <td>04</td> </tr> <tr> <td>7,94</td> <td>08</td> <td>09</td> <td>07</td> <td>07</td> <td>13</td> <td>13</td> <td>05</td> </tr> <tr> <td>8,00</td> <td>-</td> <td>-</td> <td>08</td> <td>-</td> <td>-</td> <td>-</td> <td>-</td> </tr> <tr> <td>9,52</td> <td>09</td> <td>11</td> <td>09</td> <td>09</td> <td>16</td> <td>16</td> <td>06</td> </tr> <tr> <td>10,00</td> <td>-</td> <td>-</td> <td>10</td> <td>-</td> <td>-</td> <td>-</td> <td>-</td> </tr> <tr> <td>11,11</td> <td>11</td> <td>13</td> <td>11</td> <td>11</td> <td>19</td> <td>19</td> <td>07</td> </tr> <tr> <td>12,00</td> <td>-</td> <td>-</td> <td>12</td> <td>-</td> <td>-</td> <td>-</td> <td>-</td> </tr> <tr> <td>12,70</td> <td>12</td> <td>15</td> <td>12</td> <td>12</td> <td>22</td> <td>22</td> <td>08</td> </tr> <tr> <td>14,29</td> <td>14</td> <td>17</td> <td>14</td> <td>14</td> <td>24</td> <td>24</td> <td>09</td> </tr> <tr> <td>15,88</td> <td>16</td> <td>19</td> <td>15</td> <td>15</td> <td>27</td> <td>27</td> <td>10</td> </tr> <tr> <td>16,00</td> <td>-</td> <td>-</td> <td>16</td> <td>-</td> <td>-</td> <td>-</td> <td>-</td> </tr> <tr> <td>17,46</td> <td>17</td> <td>21</td> <td>17</td> <td>17</td> <td>30</td> <td>30</td> <td>11</td> </tr> <tr> <td>19,05</td> <td>19</td> <td>23</td> <td>19</td> <td>19</td> <td>33</td> <td>33</td> <td>13</td> </tr> <tr> <td>20,00</td> <td>-</td> <td>-</td> <td>20</td> <td>-</td> <td>-</td> <td>-</td> <td>-</td> </tr> <tr> <td>22,22</td> <td>22</td> <td>27</td> <td>22</td> <td>22</td> <td>38</td> <td>38</td> <td>15</td> </tr> <tr> <td>25,00</td> <td>-</td> <td>-</td> <td>25</td> <td>-</td> <td>-</td> <td>-</td> <td>-</td> </tr> <tr> <td>25,40</td> <td>25</td> <td>31</td> <td>25</td> <td>25</td> <td>44</td> <td>44</td> <td>17</td> </tr> <tr> <td>31,75</td> <td>32</td> <td>38</td> <td>31</td> <td>31</td> <td>54</td> <td>54</td> <td>21</td> </tr> <tr> <td>32,00</td> <td>-</td> <td>-</td> <td>32</td> <td>-</td> <td>-</td> <td>-</td> <td>-</td> </tr> </tbody> </table>	D, мм	C	D	R	S	T	V	W	3,97	S4	04	03	03	06	-	-	4,76	04	05	04	03	08	08	S3	5,56	05	06	05	05	09	09	03	6,00	-	-	06	-	-	-	-	6,35	06	07	06	06	11	11	04	7,94	08	09	07	07	13	13	05	8,00	-	-	08	-	-	-	-	9,52	09	11	09	09	16	16	06	10,00	-	-	10	-	-	-	-	11,11	11	13	11	11	19	19	07	12,00	-	-	12	-	-	-	-	12,70	12	15	12	12	22	22	08	14,29	14	17	14	14	24	24	09	15,88	16	19	15	15	27	27	10	16,00	-	-	16	-	-	-	-	17,46	17	21	17	17	30	30	11	19,05	19	23	19	19	33	33	13	20,00	-	-	20	-	-	-	-	22,22	22	27	22	22	38	38	15	25,00	-	-	25	-	-	-	-	25,40	25	31	25	25	44	44	17	31,75	32	38	31	31	54	54	21	32,00	-	-	32	-	-	-	-
D, мм	C	D	R	S	T	V	W																																																																																																																																																																																													
3,97	S4	04	03	03	06	-	-																																																																																																																																																																																													
4,76	04	05	04	03	08	08	S3																																																																																																																																																																																													
5,56	05	06	05	05	09	09	03																																																																																																																																																																																													
6,00	-	-	06	-	-	-	-																																																																																																																																																																																													
6,35	06	07	06	06	11	11	04																																																																																																																																																																																													
7,94	08	09	07	07	13	13	05																																																																																																																																																																																													
8,00	-	-	08	-	-	-	-																																																																																																																																																																																													
9,52	09	11	09	09	16	16	06																																																																																																																																																																																													
10,00	-	-	10	-	-	-	-																																																																																																																																																																																													
11,11	11	13	11	11	19	19	07																																																																																																																																																																																													
12,00	-	-	12	-	-	-	-																																																																																																																																																																																													
12,70	12	15	12	12	22	22	08																																																																																																																																																																																													
14,29	14	17	14	14	24	24	09																																																																																																																																																																																													
15,88	16	19	15	15	27	27	10																																																																																																																																																																																													
16,00	-	-	16	-	-	-	-																																																																																																																																																																																													
17,46	17	21	17	17	30	30	11																																																																																																																																																																																													
19,05	19	23	19	19	33	33	13																																																																																																																																																																																													
20,00	-	-	20	-	-	-	-																																																																																																																																																																																													
22,22	22	27	22	22	38	38	15																																																																																																																																																																																													
25,00	-	-	25	-	-	-	-																																																																																																																																																																																													
25,40	25	31	25	25	44	44	17																																																																																																																																																																																													
31,75	32	38	31	31	54	54	21																																																																																																																																																																																													
32,00	-	-	32	-	-	-	-																																																																																																																																																																																													
				<table border="1"> <thead> <tr> <th>Класс</th> <th>d</th> <th>m</th> <th>t</th> </tr> </thead> <tbody> <tr> <td>A</td> <td>±0,025</td> <td>±0,006</td> <td>±0,025</td> </tr> <tr> <td>C</td> <td>±0,025</td> <td>±0,013</td> <td>±0,025</td> </tr> <tr> <td>H</td> <td>±0,013</td> <td>±0,013</td> <td>±0,025</td> </tr> <tr> <td>E</td> <td>±0,025</td> <td>±0,025</td> <td>±0,025</td> </tr> <tr> <td>G</td> <td>±0,025</td> <td>±0,025</td> <td>±0,13</td> </tr> <tr> <td>J</td> <td>±0,05≈±0,15</td> <td>±0,006</td> <td>±0,025</td> </tr> <tr> <td>K</td> <td>±0,05≈±0,15</td> <td>±0,013</td> <td>±0,025</td> </tr> <tr> <td>L</td> <td>±0,05≈±0,15</td> <td>±0,025</td> <td>±0,025</td> </tr> <tr> <td>M</td> <td>±0,05≈±0,15</td> <td>±0,08≈±0,20</td> <td>±0,13</td> </tr> <tr> <td>N</td> <td>±0,05≈±0,15</td> <td>±0,08≈±0,18</td> <td>±0,025</td> </tr> <tr> <td>U</td> <td>±0,08≈±0,25</td> <td>±0,13≈±0,38</td> <td>±0,13</td> </tr> </tbody> </table>	Класс	d	m	t	A	±0,025	±0,006	±0,025	C	±0,025	±0,013	±0,025	H	±0,013	±0,013	±0,025	E	±0,025	±0,025	±0,025	G	±0,025	±0,025	±0,13	J	±0,05≈±0,15	±0,006	±0,025	K	±0,05≈±0,15	±0,013	±0,025	L	±0,05≈±0,15	±0,025	±0,025	M	±0,05≈±0,15	±0,08≈±0,20	±0,13	N	±0,05≈±0,15	±0,08≈±0,18	±0,025	U	±0,08≈±0,25	±0,13≈±0,38	±0,13																																																																																																																																																
Класс	d	m	t																																																																																																																																																																																																	
A	±0,025	±0,006	±0,025																																																																																																																																																																																																	
C	±0,025	±0,013	±0,025																																																																																																																																																																																																	
H	±0,013	±0,013	±0,025																																																																																																																																																																																																	
E	±0,025	±0,025	±0,025																																																																																																																																																																																																	
G	±0,025	±0,025	±0,13																																																																																																																																																																																																	
J	±0,05≈±0,15	±0,006	±0,025																																																																																																																																																																																																	
K	±0,05≈±0,15	±0,013	±0,025																																																																																																																																																																																																	
L	±0,05≈±0,15	±0,025	±0,025																																																																																																																																																																																																	
M	±0,05≈±0,15	±0,08≈±0,20	±0,13																																																																																																																																																																																																	
N	±0,05≈±0,15	±0,08≈±0,18	±0,025																																																																																																																																																																																																	
U	±0,08≈±0,25	±0,13≈±0,38	±0,13																																																																																																																																																																																																	

04		08		-	MP	
6 толщина		7 радиус скругления			8 стружколом	
обозначение, мм	толщина, мм	обозначение, мм	радиус скругления	Режущая кромка (дополнительно)		
-	0,79	X0	0,04	F острая		TM Универсальная геометрия, широкая область применения
T0	1,00	01	0,1	E скругленная		HQ Чистовая и получистовая обработка
01	1,59	02	0,2	T с фаской		CQ Чистовая и получистовая обработка
T1	1,98	04	0,4	S с фаской и скруглением		GS Черновая и получистовая обработка нержавеющей стали
02	2,38	08	0,8	K с двойной фаской		HA Обработка легких сплавов и нержавеющей стали
03	3,18	12	1,2	P с двойной фаской и скруглением		HS Получистовая обработка, нержавеющая сталь
T3	3,97	16	1,6	Исполнение (дополнительно)		MQ Чистовая обработка
04	4,76	20	2,0	R правое		MA Легкая черновая, чистовая и получистовая обработка
05	5,56	24	2,4	L левое		MS Чистовая обработка нержавеющей сталей, мягких сталей и труднообрабатываемых материалов
06	6,35	28	2,8	N нейтральное		PM Получистовая обработка
07	7,94	32	3,2			PR Чистовая обработка
9	9,52	00	круглая режущая пластина			LS Получистовая обработка
11	11,11	M0				HF Получистовая геометрия. Острая режущая кромка
12	12,70	-				MM Получистовая геометрия. Хорошая ударопрочность режущей кромки
						ZM Черновая геометрия, обработка стали
						S Общая токарная обработка

допуск на C, H, R, T, W







d	допуск на d		допуск на m	
	J, K, L, M, N	U	M, N	U
6,35	±0,05	±0,08	±0,08	±0,13
9,525	±0,05	±0,08	±0,08	±0,13
12,7	±0,08	±0,13	±0,13	±0,20
15,875	±0,10	±0,18	±0,15	±0,27
19,05	±0,10	±0,18	±0,15	±0,27
25,4	±0,13	±0,25	±0,18	±0,38

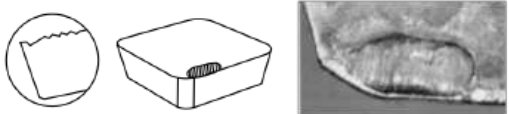
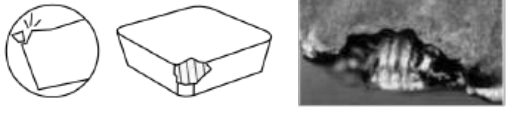

допуск на D

d	допуск на d	допуск на m
6,35	±0,05	±0,11
9,525	±0,05	±0,11
12,7	±0,08	±0,15
15,875	±0,10	±0,18
19,05	±0,10	±0,18

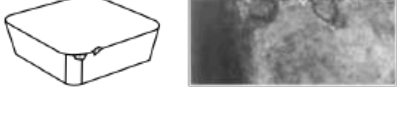
Допуски справедливы для пластин до подготовки кромки и нанесения покрытия

Точение: вопросы и ответы

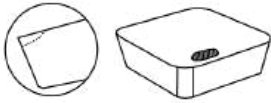
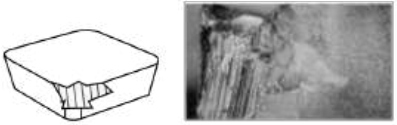
ПОВРЕЖДЕНИЕ ИНСТРУМЕНТА	ПРИЧИНА	РЕШЕНИЕ
<p>Износ передней поверхности пластины</p> 	<ol style="list-style-type: none"> 1. неподходящий материал пластины 2. Слишком большой объем материала 	<ol style="list-style-type: none"> 1. Выберите режущую пластину из другого материала 2. Уменьшите величину съема материала 3. Уменьшите скорость резания
	<ol style="list-style-type: none"> 1. неподходящий материал пластины 2. Слишком большая подача инструмента 3. Недостаточная прочность режущей кромки 4. Недостаточная жесткость державки 	<ol style="list-style-type: none"> 1. Выберите более прочный материал режущей пластины 2. Уменьшите подачу 3. Выберите державку большего размера
<p>Пластическая деформация</p> 	<ol style="list-style-type: none"> 1. неподходящий материал пластины 2. Слишком большой съем материала 3. Слишком высокая температура в зоне резания 	<ol style="list-style-type: none"> 1. Выберите более прочный материал режущей пластины 2. Уменьшите величину снимаемого припуска 3. Выберите материал режущей пластины с большей теплопроводностью
<p>Износ кромки (задняя поверхность пластины)</p> 	<ol style="list-style-type: none"> 1. Твердость заготовки слишком высока по отношению к инструменту 2. Обработка детали с закаленной поверхностью 3. неподходящий материал пластины 4. Слишком высокая скорость резания 5. Задний угол слишком мал 6. Слишком низкая подача инструмента 	<ol style="list-style-type: none"> 1. Выберите более твердый материал режущей пластины 2. Уменьшите скорость резания 3. Выберите режущую пластину с большим задним углом 4. Увеличьте подачу
<p>Термические повреждения</p> 	<ol style="list-style-type: none"> 1. Слишком высокая температура в зоне резания 2. неподходящий материал пластины 3. Особенности заточки 	<ol style="list-style-type: none"> 1. Не используйте СОЖ (если обработка без СОЖ невозможна, необходима обильная подача СОЖ) 2. Выберите материал режущей пластины с более высокой прочностью
<p>Сколы края</p> 	<ol style="list-style-type: none"> 1. неподходящий материал пластины 2. Слишком большая подача инструмента 3. Снижение прочности режущей кромки 4. Недостаточная жесткость державки 	<ol style="list-style-type: none"> 1. Выберите материал с более высокой прочностью 2. Уменьшите подачу 3. Выберите державку большего размера
<p>Износ пластины</p> 	<ol style="list-style-type: none"> 1. Заготовка с закаленным поверхностным слоем 2. Трение или вибрации из-за неверно выбранной геометрии пластины 	<ol style="list-style-type: none"> 1. Выберите более твердый материал режущей пластины 2. Выберите пластину с большим задним углом

ПОВРЕЖДЕНИЕ ИНСТРУМЕНТА	ПРИЧИНА	РЕШЕНИЕ
<p>Отслаивание</p> 	<ol style="list-style-type: none"> 1. Отсоединение насадок 2. Плохой контроль стружкообразования 	<ol style="list-style-type: none"> 1. Используйте пластину с большим передним углом 2. Выберите другую геометрию пластины
<p>Поломка</p> 	<ol style="list-style-type: none"> 1. Выкрашивание 	<ol style="list-style-type: none"> 1. Уменьшите подачу 2. Уменьшите глубину резания 3. Выберите материал пластины с более высокой прочностью 4. Выберите другой стружколом для улучшения стружкодробления 5. Выберите более толстую пластину
<p>Образование наклепа</p> 	<ol style="list-style-type: none"> 1. Скорость резания слишком низкая 	<ol style="list-style-type: none"> 1. Увеличьте скорость резания 2. Выберите пластину с большим задним углом 3. Выберите материал режущей пластины с большей прочностью

Химическое покрытие

ISO	P		M		K	
05	LF9011					
10		LF9018				LF3018
15				LF6011		
20						
25		NEW				NEW
30		LF9028				
35				LF6018		NEW
40						

Сплав CVD представляет собой покрытие $TiCN, A_2O_3$ и т.д. толщиной от 3 до 16 мкм. Сплав обладает лучшей износостойкостью, термостойкостью, стойкостью к окислению, химической стабильностью и другими характеристиками, чем цементированный карбид. Инструменты с покрытием CVD имеют более длительный срок службы и подходят для высокоскоростной обработки.

Новая технология сглаживания поверхности SHAOТЕС, реализованная в основных материалах для покрытий, может снизить коэффициент трения поверхности при одновременном уменьшении явления концентрации микроскопических напряжений, особенно в отношении антиадгезии, износостойкости, стойкости к сколам, что значительно улучшает эксплуатационные характеристики материала инструмента.

Сплавы CVD для токарной обработки стали серии LF9000













































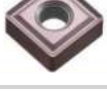

























Благодаря технологии увеличения плотности и стабилизации столбчатых кристаллов, новые инструментальные сплавы LF9011 и LF9018 могут существенно снизить стоимость обработки резанием. Основной причиной повреждения режущей кромки является появление микротрещин. Наши новые сплавы в сочетании с применением новой технологии финишной обработки пластин SHAOТЕС позволяют серьезно снизить вероятность их появления и тем самым максимально увеличить срок службы режущего инструмента.







Применение	Материал	Матрица			Покрытие		Особенности	
	Код классиф. ISO	Удельный вес	Твердость HRA	Прочность на изгиб ГПА	Основной ингредиент	Толщина мкм		
Сталь	LF9008	13.9	91	2.5	Изоотопный столбчатый кристалл TiCN+A ₂ O ₃	16	<p>Материалы для обработки стали. Благодаря внедрению новой технологии финишной обработки поверхности SHAOPEC производительность инструментального сплава сильно увеличилась. Благодаря применению технологии стабилизации столбчатых кристаллов, их размеры и ориентация максимально уравниваются. Таким образом снижается вероятность появления и дальнейшего увеличения трещин в покрытии. Вырастает сопротивляемость разрушению.</p> <p>Одновременно с этим плотность покрытия была также увеличена. Сплав LF9008 обеспечивает не только превосходную износостойкость, но и устойчивость к сколам при различных условиях резания.</p> <p>Сплав LF9018 является его модификацией, которая кроме еще большей устойчивости к образованию сколов обеспечивает стабильный прогнозируемый срок службы инструмента при получистовой и чистовой обработке даже в условиях прерывистого резания.</p>	
	P10-P20							
	LF9018	13.7	90.0	2.6		16		
	P20-P30							
	LF9028	13.5	89.0	2.6		14		<p>Материалы для обработки стали. Хорошая устойчивость к отслаиванию достигается благодаря эффекту двойного моста LF9028, обладая чрезвычайно высокой устойчивостью к сколам, больше подходит для обработки с большим съемом материала в условиях прерывистого резания.</p>
	P30-P40							







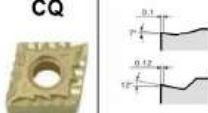



Базовые стружколомы

Стружколомы для токарной обработки (пластины с отрицательной геометрией)

Стружколом	C	D	S	T	W	V
Отрицательная геометрия	 Ромб 80°	 Ромб 55°	 Квадрат 90°	 Треугольник 60°	 Ломанный треугольник 80°	 Ромб 35°
TM						
HQ						
CQ						
GS						
MA						
MS						
HA						
HS						
PR						
PM						
MS						
-						

Стружколомы для токарной обработки

Форма	Геометрия передней поверхн.	Диапазон применения														Технические характеристики и рекомендации	
		Подача - мм/об															
		0.04	0.063	0.10	0.16	0.25	0.4	0.63	1.0	1.6	2.5	4.0	6.3				
		Глубина резания															
		0.1	0.16	0.25	0.4	0.63	1.0	1.6	2.5	4.0	6.3	10.0	11.6	13			
Для тонкой обработки	<p>MA</p> 						0.1 ~ 0.5			0.9 ~ 4							Стружколом рекомендован для обработки углеродистых и легированных сталей, чугуна.
Для тонкой обработки	<p>MS</p> 						0.1 ~ 0.5			0.9 ~ 4							Чистовая и получистовая обработка низкоуглеродистых и легированных сталей, нержавеющей стали
Чист. получист. обработка	<p>CQ</p> 						0.1 ~ 0.5			0.9 ~ 4							Отлично работает при переменной глубине резания с малыми подачами
Чист. обработка	<p>MQ</p> 						0.1 ~ 0.5			0.9 ~ 4							Большой передний угол Низкие усилия резания
Чист. получист. обработка	<p>MS</p> 						0.1 ~ 0.5			0.9 ~ 4							Положительная геометрия превосходна для чистовой обработки

Форма	Геометрия передней поверхн.	Диапазон применения													Технические характеристики и рекомендации
		Подача - мм/об													
		0.04	0.063	0.10	0.16	0.25	0.4	0.63	1.0	1.6	2.5	4.0	6.3		
		Глубина резания													
		0.1	0.16	0.25	0.4	0.63	1.0	1.6	2.5	4.0	6.3	10.0	11.6	13	
Серия H	 HA					0.03 ~ 0.3			0.5 ~ 2.5						Универсальная и чистовая обработка - острая режущая кромка обеспечивает небольшие усилия резания - особопрочная главная режущая кромка - обработка низкоуглерод. и нерж. сталей и алюминия
Серия H	 HS					0.1 ~ 0.4			1.0 ~ 4.0						Получистовая обработка нерж. стали - уникальная геометрия для обработки нерж. стали обеспечивает длительный срок работы пластины - большой передний угол и повышенная износостойкость пластины
Серия G	 GS					0.15 ~ 0.5			1.5 ~ 5.5						Получистовая черновая обработка нерж. стали - специальный стружколом для нерж. стали
Серия для обработки алюминиевых сплавов	 AL					0.03 ~ 0.4			0.1 ~ 4.0						Черновая и получистовая обработка алюминиевых сплавов - большой передний угол и низкое сопротивление резанию, долгий срок службы в условиях непрерывного резания - высокоскорост. обработка
Для обработки чугуна	 					0.1 ~ 0.5			0.9 ~ 4						Черновая обработка чугуна - высокая прочность режущей кромки - идеальна в условиях прерывистого резания

Инструментальные сплавы

МАТЕРИАЛ	ХАРАКТЕРИСТИКА
LF9008	Чистовая и получистовая обработка углеродистых и легированных сталей. Износостойкость выше, чем у LF9018
LF9018	Более широкий диапазон применения при обработке углеродистых и легированных сталей по сравнению с LF9008
LF9028	Черновая обработка легированных и углеродистых сталей
LF6011	Благодаря хорошей износостойкости покрытия идеален для алюминиевых и медных сплавов, получистовой и чистовой обработки чугуна, особенно при обработке канавок
LF6018	Сплав с превосходной ударной вязкостью и антиадгезионной износостойкостью разработан для аустенитной нержавеющей стали. Подходит для обработки жаропрочных легированных сталей на низких скоростях резания
LF6118	Подходит для всех типов стали и чугуна. Оптимален для обработки нержавеющей сталей
LF3018	Обладает хорошей износостойкостью и ударной вязкостью. Подходит для получистовой и чистовой обработки обычного и ковкого чугунов
LF90	Подходит для получистовой и чистовой обработки стали и чугуна. Высокая твердость и низкая способность к адгезии. Хорошая химическая стабильность, термостойкость и износостойкость.
K10	Обеспечивает низкие силы трения при резании в условиях непрерывной и прерывистой обработки алюминиевых сплавов.

CNMG 12 04 04 --

длина режущей кромки, l толщина, S радиус скругления режущей кромки, r код стружколома

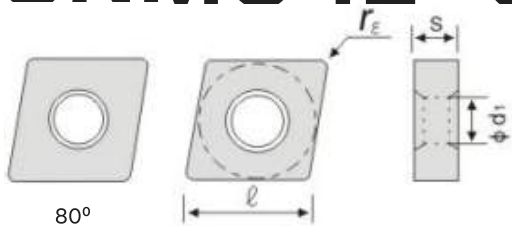

CN __	0903 __	1204 __	1606 __	1906 __	2509 __
$\varnothing d1$ (мм)	3.81	5.16	6.35	7.93	9.12

Отрицательная геометрия ● в наличии ○ под заказ

Форма СМП	Модель	Размеры					P			M			K						
		L	\varnothing l.C	S	\varnothing L1	r	LF9008	LF9018	LF9028	LF9218	LF9118	LF918	LF6008	LF6018	LF6028	LF6118	LF618	LF3018	LF3028
	CNMG120404-HQ	12.9	12.7	4.76	5.16	0.4	●	●											
	CNMG120408-HQ	12.9	12.7	4.76	5.16	0.8	●	●											
	CNMG120408-CQ	12.9	12.7	4.76	5.16	0.8	●	●											
	CNMG120412-CQ	12.9	12.7	4.76	5.16	1.2	○	○											
	CNMG120404-CQ	12.9	12.7	4.76	5.16	0.4				●									
	CNMG120408-CQ	12.9	12.7	4.76	5.16	0.8				●									
	CNMG120412-CQ	12.9	12.7	4.76	5.16	1.2				●									
	CNMG120408-CQ	12.9	12.7	4.76	5.16	0.8				●									
	CNMG120408-CQ	12.9	12.7	4.76	5.16	0.8				●									
	CNMG120404-TF	12.9	12.7	4.76	5.16	0.4					●								
	CNMG120408-TF	12.9	12.7	4.76	5.16	0.8					●								
	CNMG120404-TM	12.9	12.7	4.76	5.16	0.4	●	●											
	CNMG120408-TM	12.9	12.7	4.76	5.16	0.8	●	●											
	CNMG120412-TM	12.9	12.7	4.76	5.16	1.2	○	○											
	CNMG120404-TM	12.9	12.7	4.76	5.16	0.4				●									
	CNMG120408-TM	12.9	12.7	4.76	5.16	0.8				●									
	CNMG120412-TM	12.9	12.7	4.76	5.16	1.2				●									
	CNMG120404-TM	12.9	12.7	4.76	5.16	0.4				●									
	CNMG120408-TM	12.9	12.7	4.76	5.16	0.8				●									
	CNMG120408-TM	12.9	12.7	4.76	5.16	0.8				●									
	CNMG160608-ZS	16.1	15.875	6.35	6.35	0.8				●									
	CNMG120404-MQ	12.9	12.7	4.76	5.16	0.4												●	
	CNMG120408-MQ	12.9	12.7	4.76	5.16	0.8												●	

CNMG 12 04 04 --

длина режущей кромки, l толщина, S радиус скругления режущей кромки, r код стружколома

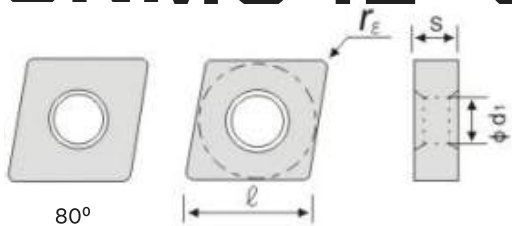

CN __	0903 __	1204 __	1606 __	1906 __	2509 __
$\varnothing d1$ (мм)	3.81	5.16	6.35	7.93	9.12

Отрицательная геометрия ● в наличии ○ под заказ

Форма СМП	Модель	Размеры					P		M			K								
		L	$\varnothing I.C$	S	$\varnothing L1$	r	LF9008	LF9018	LF9028	LF9218	LF9118	LF918	LF6008	LF6018	LF6028	LF6118	LF618	LF3018	LF3028	
	CNMG120404-MM	12.9	12.7	4.76	5.16	0.4														
	CNMG120408-MM	12.9	12.7	4.76	5.16	0.8														
	CNMG120404-HS	12.9	12.7	4.76	5.16	0.4						●	●							
	CNMG120408-HS	12.9	12.7	4.76	5.16	0.8						●	●							
	CNMG120412-HS	12.9	12.7	4.76	5.16	1.2						○	○							
	CNMG190612-HS	19.3	19.05	6.35	7.94	1.2						○	○							
	CNMG120404-HS	12.9	12.7	4.76	5.16	0.4														
	CNMG120408-HS	12.9	12.7	4.76	5.16	0.8														
	CNMG120404-MA	12.9	12.7	4.76	5.16	0.4						●	●							
	CNMG120408-MA	12.9	12.7	4.76	5.16	0.8						●	●							
	CNMG120412-MA	12.9	12.7	4.76	5.16	1.2						○	○							
	CNMG120404-MA	12.9	12.7	4.76	5.16	0.4														
	CNMG120408-MA	12.9	12.7	4.76	5.16	0.8														
	CNMG120408-MS	12.9	12.7	4.76	5.16	0.8														
	CNMG120404-MS	12.9	12.7	4.76	5.16	0.4						●	●							
	CNMG120408-MS	12.9	12.7	4.76	5.16	0.8						●	●							
	CNMG190612-MS	19.3	19.05	6.35	7.94	1.2						○	○							
	CNMG120404-MS	12.9	12.7	4.76	5.16	0.4														●
	CNMG120408-MS	12.9	12.7	4.76	5.16	0.8														●
	CNMG120412-MS	12.9	12.7	4.76	5.16	1.2														●

CNMG 12 04 04 --

длина режущей кромки, l толщина, S радиус скругления режущей кромки, r код стружколома

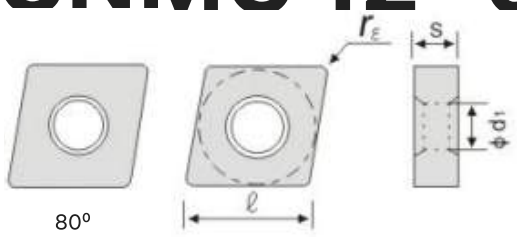

CN __	0903 __	1204 __	1606 __	1906 __	2509 __
$\varnothing d1$ (мм)	3.81	5.16	6.35	7.93	9.12

Отрицательная геометрия ● в наличии ○ под заказ

Форма СМП	Модель	Размеры					P					M		K					
		L	$\varnothing I.C$	S	$\varnothing L1$	r	LF9008	LF9018	LF9028	LF9218	LF9118	LF918	LF6008	LF6018	LF6028	LF6118	LF618	LF3018	LF3028
	CNMG120404	12.9	12.7	4.76	5.16	0.4													●
	CNMG120408	12.9	12.7	4.76	5.16	0.8													●
	CNMG120412	12.9	12.7	4.76	5.16	1.2													●



DNMG 15 04 04 --

длина режущей кромки, l толщина, S радиус скругления режущей кромки, r код стружколома



55°

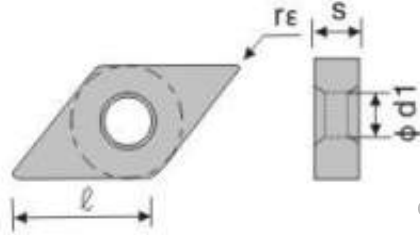

DN __	1104 __	1504 __	1506 __
Ø d1 (мм)	3.81	5.16	5.16

Отрицательная геометрия ● в наличии ○ под заказ

Форма СМП	Модель	Размеры					P			M			K						
		L	Ø I.C	S	Ø L1	r	LF9008	LF9018	LF9028	LF9218	LF9118	LF918	LF6008	LF6018	LF6028	LF6118	LF618	LF3018	LF3028
	DNMG150404-TM	15.5	12.7	4.76	5.16	0.4	●	●											
	DNMG150408-TM	15.5	12.7	4.76	5.16	0.8	●	●											
	DNMG150404-TM	15.5	12.7	4.76	5.16	0.4			●										
	DNMG150408-TM	15.5	12.7	4.76	5.16	0.8			●										
	DNMG150612-PM	15.5	12.7	6.35	5.16	1.2	○	○		○									
	DNMG150408-PM	15.5	12.7	4.76	5.16	0.8			●										
	DNMG150608-HS	15.5	12.7	6.35	5.16	0.8							○						
	DNMG150612-HS	15.5	12.7	6.35	5.16	1.2							○						

SNMG 12 04 04 - -

длина режущей кромки, l

толщина, S

радиус скругления режущей кромки, r

код стружколома



90°

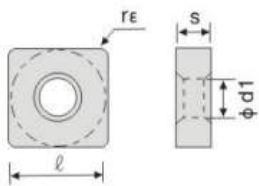

SN __	0903 __	1204 __	1506 __	1906 __	2507(09) __	3109 __
Ø d1 (мм)	3.81	5.16	6.35	7.93	9.12	8.80

Отрицательная геометрия ● в наличии ○ под заказ

Форма СМП	Модель	Размеры					P					M		K					
		L	Ø I.C	S	Ø L1	r	LF9008	LF9018	LF9028	LF9218	LF9118	LF918	LF6008	LF6018	LF6028	LF6118	LF618	LF3018	LF3028
	SNMG120404-TM	12.7	12.7	4.76	5.16	0.4	●	●											
	SNMG120408-TM	12.7	12.7	4.76	5.16	0.8	●	●											
	SNMG120412-TM	12.7	12.7	4.76	5.16	1.2	●	●											
	SNMG120408-TM	12.7	12.7	4.76	5.16	0.8				●									
	SNMG120408L-S	12.9	12.7	4.76	5.16	0.8				●									
	SNMG120408R-S	12.7	12.7	4.76	5.16	0.8				●									
	SNMG120408L-S	12.7	12.7	4.76	5.16	0.8					●								
	SNMG120408R-S	12.7	12.7	4.76	5.16	0.8						●							
	SNMG120404-HA	12.7	12.7	4.76	5.16	0.4						●	●						
	SNMG120408-HA	12.7	12.7	4.76	5.16	0.8						●	●						
	SNMG120404-HS	12.7	12.7	4.76	5.16	0.4						●	●						
	SNMG120408-HS	12.7	12.7	4.76	5.16	0.8						●	●						
	SNMG120404L-S	12.7	12.7	4.76	5.16	0.4						●	●						
	SNMG120408L-S	12.7	12.7	4.76	5.16	0.8						●	●						
	SNMG120408R-S	12.7	12.7	4.76	5.16	0.8						●	●						
	SNMG120404-MM	12.9	12.7	4.76	5.16	0.4												●	
	SNMG120408-MM	12.9	12.7	4.76	5.16	0.8												●	

SNMG 12 04 04 - -

длина режущей кромки, l

толщина, S

радиус скругления режущей кромки, r

код стружколома



90°

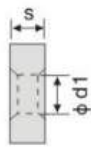

SN __	0903 __	1204 __	1506 __	1906 __	2507(09) __	3109 __
Ø d1 (мм)	3.81	5.16	6.35	7.93	9.12	8.80

Отрицательная геометрия ● в наличии ○ под заказ

Форма СМП	Модель	Размеры					P		M			K									
		L	Ø I.C	S	Ø L1	r	LF9008	LF9018	LF9028	LF9218	LF9118	LF918	LF6008	LF6018	LF6028	LF6118	LF618	LF3018	LF3028		
	SNMG120404-MA	12.7	12.7	4.76	5.16	0.4															
	SNMG120408-MA	12.7	12.7	4.76	5.16	0.8															
	SNMG120404-MA	12.7	12.7	4.76	5.16	0.4															
	SNMG120408-MA	12.7	12.7	4.76	5.16	0.8															
	SNMG120404-MA	12.7	12.7	4.76	5.16	0.4															
	SNMG120408-MA	12.7	12.7	4.76	5.16	0.8															
	SNMG120412-MA	12.7	12.7	4.76	5.16	1.2															
	SNMG120404-MS	12.7	12.7	4.76	5.16	0.4															
	SNMG120408-MS	12.7	12.7	4.76	5.16	0.8															
	SNMG120404-MS	12.7	12.7	4.76	5.16	0.4															
	SNMG120408-MS	12.7	12.7	4.76	5.16	0.8															
	SNMG120404-MS	12.7	12.7	4.76	5.16	0.4															
	SNMG120408-MS	12.7	12.7	4.76	5.16	0.8															
	SNMG120412-MS	12.7	12.7	4.76	5.16	1.2															
	SNMG120404-MS	12.7	12.7	4.76	5.16	0.4															
	SNMG120408-MS	12.7	12.7	4.76	5.16	0.8															
	SNMG120412-MS	12.7	12.7	4.76	5.16	1.2															
	SNMG120404	12.7	12.7	4.76	5.16	0.4															
	SNMG120408	12.7	12.7	4.76	5.16	0.8															
	SNMG120412	12.7	12.7	4.76	5.16	1.2															

TNMG 16 04 04 --

длина режущей кромки, l толщина, S радиус скругления режущей кромки, r код стружколома

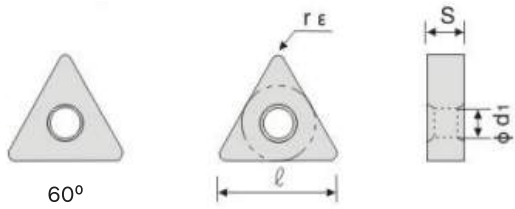

TN __	1103 __	1603 __	1604 __	2204 __
Ø d1 (мм)	2.26	3.81	3.81	5.16

Отрицательная геометрия ● в наличии ○ под заказ

Форма СМП	Модель	Размеры					P			M			K						
		L	Ø I.C	S	Ø L1	r	LF9008	LF9018	LF9028	LF9218	LF9118	LF918	LF6008	LF6018	LF6028	LF6118	LF618	LF3018	LF3028
	TNMG160404-HQ	16.5	9.525	4.76	3.81	0.4	●	●											
	TNMG160408-HQ	16.5	9.525	4.76	3.81	0.8	●	●											
	TNMG110404-HQ	11	6.35	4.76	2.26	0.4			●										
	TNMG110408-HQ	11	6.35	4.76	2.26	0.8			●										
	TNMG160404-HQ	16.5	9.525	4.76	3.81	0.4				●									
	TNMG160408-HQ	16.5	9.525	4.76	3.81	0.8				●									
	TNMG160404-CQ	16.5	9.525	4.76	3.81	0.4				●									
	TNMG160408-CQ	16.5	9.525	4.76	3.81	0.8				●									
	TNMG160412-CQ	16.5	9.525	4.76	3.81	1.2				○									
	TNMG160404-CQ	16.5	9.525	4.76	3.81	0.4	●	●											
	TNMG160408-CQ	16.5	9.525	4.76	3.81	0.8	●	●											
	TNMG160412-CQ	16.5	9.525	4.76	3.81	1.2	○	○											
	TNMG160404-CQ	16.5	9.525	4.76	3.81	0.4					●								
	TNMG160408-CQ	16.5	9.525	4.76	3.81	0.8					●								
	TNMG160404-TM	16.5	9.525	4.76	3.81	0.4	●	●											
	TNMG160408-TM	16.5	9.525	4.76	3.81	0.8	●	●											
	TNMG160412-TM	16.5	9.525	4.76	3.81	1.2	●	●											
	TNMG220416-TM	22	12.7	4.76	5.16	1.6	○	○											
	TNMG160404-TM	16.5	9.525	4.76	3.81	0.4						●							
	TNMG160408-TM	16.5	9.525	4.76	3.81	0.8						●							
	TNMG160408-CM	16.5	9.53	4.76	3.81	0.8	●	●											
	TNMG160412-CM	16.5	9.53	4.76	3.81	1.2	●	●											

TNMG 16 04 04 --

длина режущей кромки, l толщина, S радиус скругления режущей кромки, r код стружколома



60°

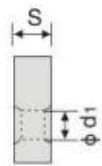

TN __	1103 __	1603 __	1604 __	2204 __
Ø d1 (мм)	2.26	3.81	3.81	5.16

Отрицательная геометрия ● в наличии ○ под заказ

Форма СМП	Модель	Размеры					P						M				K		
		L	Ø I.C	S	Ø L1	r	LF9008	LF9018	LF9028	LF9218	LF9118	LF918	LF6008	LF6018	LF6028	LF6118	LF618	LF3018	LF3028
	TNMG160408-CM	16.5	9.53	4.76	3.81	0.8													
	TNMG160412-CM	16.5	9.53	4.76	3.81	1.2													
	TNMG160404R-S	16.5	9.525	4.76	3.81	0.4	●	●											
	TNMG160404L-S	16.5	9.525	4.76	3.81	0.4	●	●											
	TNMG160408R-S	16.5	9.525	4.76	3.81	0.8	●	●											
	TNMG160408L-S	16.5	9.525	4.76	3.81	0.8	●	●											
	TNMG160404R-S	16.5	9.525	4.76	3.81	0.4													
	TNMG160408R-S	16.5	9.525	4.76	3.81	0.8													
	TNMG160408L-S	16.5	9.525	4.76	3.81	0.8													
	TNMG160408R-S	16.5	9.525	4.76	3.81	0.8													
	TNMG160404L-S	16.5	9.525	4.76	3.81	0.4													
	TNMG160408L-S	16.5	9.525	4.76	3.81	0.8													
	TNMG160408-PM	16.5	9.525	4.76	3.81	0.8													
	TNMG220418-PM	22	12.7	4.76	5.16	0.8													
	TNMG220412-PM	22	12.7	4.76	5.16	1.2													
	TNMG160412-PR	16.5	9.525	4.76	3.81	1.2	●	●											
	TNMG160404-MQ	16.5	9.53	4.76	3.81	0.4													
	TNMG160408-MQ	16.5	9.53	4.76	3.81	0.8													
	TNMG160412-MQ	16.5	9.53	4.76	3.81	1.2													

TNMG 16 04 04 --

длина режущей кромки, l

толщина, S

радиус скругления режущей кромки, r

код стружколома



60°

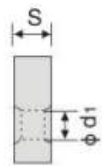

TN __	1103 __	1603 __	1604 __	2204 __
Ø d1 (мм)	2.26	3.81	3.81	5.16

Отрицательная геометрия ● в наличии ○ под заказ

Форма СМП	Модель	Размеры					P					M			K				
		L	Ø I.C	S	Ø L1	r	LF9008	LF9018	LF9028	LF9218	LF9118	LF918	LF6008	LF6018	LF6028	LF6118	LF618	LF3018	LF3028
	TNMG160404-MQ	16.5	9.53	4.76	3.81	0.4													●
	TNMG160408-MQ	16.5	9.53	4.76	3.81	0.8													●
	TNMG160404-HA	16.5	9.525	4.76	3.81	0.4						●	●						
	TNMG160408-HA	16.5	9.525	4.76	3.81	0.8						●	●						
	TNMG160404-HA	16.5	9.525	4.76	3.81	0.4													●
	TNMG160408-HA	16.5	9.525	4.76	3.81	0.8													●
	TNMG160404-HS	16.5	9.525	4.76	3.81	0.4						●	●						
	TNMG160408-HS	16.5	9.525	4.76	3.81	0.8						●	●						
	TNMG160404-HS	16.5	9.525	4.76	3.81	0.4													●
	TNMG160408-HS	16.5	9.525	4.76	3.81	0.8													●
	TNMG160404R-S	16.5	9.525	4.76	3.81	0.4													●
	TNMG160408R-S	16.5	9.525	4.76	3.81	0.8													●
	TNMG160404L-S	16.5	9.525	4.76	3.81	0.4													●
	TNMG160408L-S	16.5	9.525	4.76	3.81	0.8													●
	TNMG160404-MA	16.5	9.525	4.76	3.81	0.4						●	●						
	TNMG160408-MA	16.5	9.525	4.76	3.81	0.8						●	●						
	TNMG160408-MA	16.5	9.525	4.76	3.81	0.8													●
	TNMG160404-MA	16.5	9.525	4.76	3.81	0.4						●	●						
	TNMG160408-MA	16.5	9.525	4.76	3.81	0.8						●	●						
	TNMG160404-MA	16.5	9.525	4.76	3.81	0.4													●
	TNMG160408-MA	16.5	9.53	4.76	3.81	0.8													●

TNMG 16 04 04 --

длина режущей кромки, l толщина, S радиус скругления режущей кромки, r код стружколома



60°

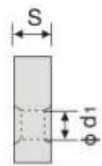

TN __	1103 __	1603 __	1604 __	2204 __
Ø d1 (мм)	2.26	3.81	3.81	5.16

Отрицательная геометрия ● в наличии ○ под заказ

Форма СМП	Модель	Размеры					P						M		K				
		L	Ø l.c	S	Ø L1	r	LF9008	LF9018	LF9028	LF9218	LF9118	LF918	LF6008	LF6018	LF6028	LF6118	LF618	LF3018	LF3028
	TNMG160404-MS	16.5	9.525	4.76	3.81	0.4													
	TNMG160408-MS	16.5	9.525	4.76	3.81	0.8													
	TNMG160404-MS	16.5	9.525	4.76	3.81	0.4													
	TNMG160408-MS	16.5	9.525	4.76	3.81	0.8													
	TNMG160404-MS	16.5	9.525	4.76	3.81	0.4													
	TNMG160408-MS	16.5	9.525	4.76	3.81	0.8													
	TNMG160404-MS	16.5	9.525	4.76	3.81	1.2													
	TNMG160408-JMS	16.5	9.53	4.76	3.81	0.8													
	TNMG160404-JMS	16.5	9.53	4.76	3.81	0.4													
	TNMG160408-JMS	16.5	9.53	4.76	3.81	0.8													
	TNMG160404-MS	16.5	9.525	4.76	3.81	0.4													
	TNMG160408-MS	16.5	9.525	4.76	3.81	0.8													
	TNMG160404	16.5	9.525	4.76	3.81	0.4													
	TNMG160408	16.5	9.525	4.76	3.81	0.8													

WNMG 08 04 04 --

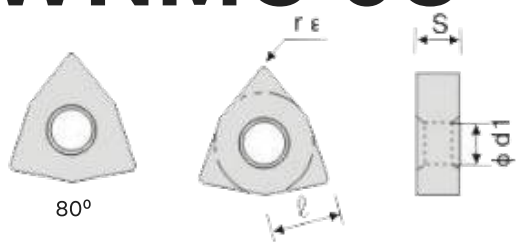

WN__	0604__	0804__	1006__	1306__
$\varnothing d1$ (мм)	3.81	5.16	6.35	7.93

Отрицательная геометрия ● в наличии ○ под заказ

Форма СМП	Модель	Размеры					P			M			K						
		L	$\varnothing I.C$	S	$\varnothing L1$	r	LF9008	LF9018	LF9028	LF9218	LF9118	LF918	LF6008	LF6018	LF6028	LF6118	LF618	LF3018	LF3028
	WNMG060404-TM	6.5	9.525	4.76	3.81	0.4	○	○											
	WNMG060408-TM	6.5	9.525	4.76	3.81	0.8	○	○											
	WNMG080404-TM	8.7	12.7	4.76	5.16	0.4	●	●											
	WNMG080408-TM	8.7	12.7	4.76	5.16	0.8	●	●											
	WNMG080412-TM	8.7	12.7	4.76	5.16	1.2	●	●											
	WNMG080404-TM	8.7	12.7	4.76	5.16	0.4	○	○	●										
	WNMG080408-TM	8.7	12.7	4.76	5.16	0.8	○	○	●										
	WNMG080412-TM	8.7	12.7	4.76	5.16	1.2	●	●	●										
	WNMG080404-TM	8.7	12.7	4.76	5.16	0.4				●									
	WNMG080408-TM	8.7	12.7	4.76	5.16	0.8				●									
	WNMG080404-HQ	8.7	12.7	4.76	5.16	0.4	●	●											
	WNMG080408-HQ	8.7	12.7	4.76	5.16	0.8	●	●											
	WNMG080404-HQ	8.7	12.7	4.76	5.16	0.4				●									
	WNMG080408-HQ	8.7	12.7	4.76	5.16	0.8				●									
	WNMG080404-HQ	8.7	12.7	4.76	5.16	0.4				●									
	WNMG080408-HQ	8.7	12.7	4.76	5.16	0.8				●									
	WNMG080412-HQ	8.7	12.7	4.76	5.16	1.2				●									
	WNMG080404-CQ	8.7	12.7	4.76	5.16	0.4	●	●											
	WNMG080408-CQ	8.7	12.7	4.76	5.16	0.8	●	●											
	WNMG080412-CQ	8.7	12.7	4.76	5.16	1.2	●	●											
	WNMG080404-CQ	8.7	12.7	4.76	5.16	0.4				●									
	WNMG080408-CQ	8.7	12.7	4.76	5.16	0.8				●									
	WNMG080412-CQ	8.7	12.7	4.76	5.16	1.2				●									

WNMG 08 04 04 --

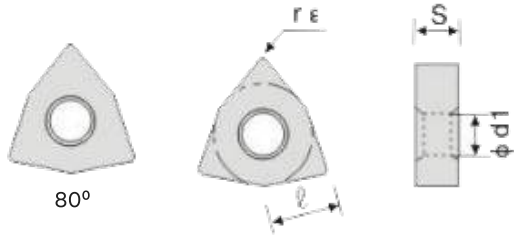

WN__	0604__	0804__	1006__	1306__
Ø d1 (мм)	3.81	5.16	6.35	7.93

Отрицательная геометрия ● в наличии ○ под заказ

Форма СМП	Модель	Размеры					P					M			K				
		L	Ø I.C	S	Ø L1	r	LF9008	LF9018	LF9028	LF9218	LF9118	LF918	LF6008	LF6018	LF6028	LF6118	LF618	LF3018	LF3028
	WNMG080404-CM	8.7	12.7	4.76	3.81	0.4	●	●											
	WNMG080408-CM	8.7	12.7	4.76	3.81	0.8	●	●											
	WNMG080408-CM	8.7	12.7	4.76	5.16	0.8				●									
	WNMG080408L-S	8.7	12.7	4.76	5.16	0.8		●	●										
	WNMG080408R-S	8.7	12.7	4.76	5.16	0.8		●	●										
	WNMG060404L-S	8.7	12.7	4.76	5.16	0.4				●									
	WNMG060408L-S	8.7	12.7	4.76	5.16	0.8				●									
	WNMG080408R-S	8.7	12.7	4.76	5.16	0.8				●									
	WNMG080408L-S	8.7	12.7	4.76	5.16	0.8					●								
	WNMG080404R-S	8.7	12.7	4.76	5.16	0.4					●								
	WNMG080408R-S	8.7	12.7	4.76	5.16	0.8					●								
	WNMG080404-MT	8.7	12.7	4.76	5.16	0.4					●								
	WNMG080408-MT	8.7	12.7	4.76	5.16	0.8					●								
	WNMG080404-PM	8.7	12.7	4.76	5.16	0.4					●								
	WNMG080408-PM	8.7	12.7	4.76	5.16	0.8					●								
	WNMG080408-PM	8.7	12.7	4.76	5.16	0.4						●							
	WNMG080408-PR	8.7	12.7	4.76	5.16	0.8	●	●											
	WNMG080412-PR	8.7	12.7	4.76	5.16	1.2	●	●											

WNMG 08 04 04 --

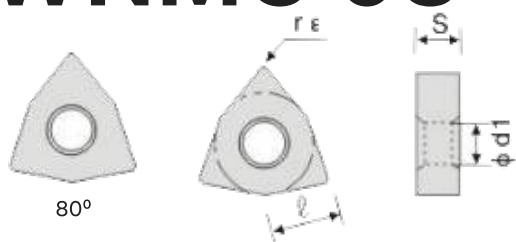

WN __	0604 __	0804 __	1006 __	1306 __
∅ d1 (мм)	3.81	5.16	6.35	7.93

Отрицательная геометрия ● в наличии ○ под заказ

Форма СМП	Модель	Размеры					P			M			K						
		L	∅ I.C	S	∅ L1	r	LF9008	LF9018	LF9028	LF9218	LF9118	LF918	LF6008	LF6018	LF6028	LF6118	LF618	LF3018	LF3028
	WNMG080408-PR	6.5	9.525	4.76	3.81	0.8		●											
	WNMG080412-PR	6.5	9.525	4.76	3.81	1.2		●											
	WNMG080412-ZM	8.7	12.7	4.76	5.16	1.2		●											
	WNMG080404-TF	8.7	12.7	4.76	5.16	0.4					●								
	WNMG080408-TF	8.7	12.7	4.76	5.16	0.8					●								
	WNMG080404-MQ	8.7	12.7	4.76	5.16	0.4						●							
	WNMG080408-MQ	8.7	12.7	4.76	5.16	0.8						●							
	WNMG080404-MQ	8.7	12.7	4.76	5.16	0.4							●						
	WNMG080408-MQ	8.7	12.7	4.76	5.16	0.8							●						
	WNMG060404-HA	6.5	9.525	4.76	3.81	0.4						○	○						
	WNMG060408-HA	6.5	9.525	4.76	3.81	0.8						○	○						
	WNMG080404-HA	8.7	12.7	4.76	5.16	0.4						●	●						
	WNMG080408-HA	8.7	12.7	4.76	5.16	0.8						●	●						
	WNMG080404-HA	8.7	12.7	4.76	5.16	0.4										●			
	WNMG080408-HA	8.7	12.7	4.76	5.16	0.8										●			
	WNMG080404L-S	8.7	12.7	4.76	5.16	0.4										●			
	WNMG080408L-S	8.7	12.7	4.76	5.16	0.8										●			
	WNMG080404R-S	8.7	12.7	4.76	5.16	0.4										●			
	WNMG080408R-S	8.7	12.7	4.76	5.16	0.8										●			
	WNMG080404-HS	8.7	12.7	4.76	5.16	0.4						●	●						
	WNMG080408-HS	8.7	12.7	4.76	5.16	0.8						●	●						

WNUMG 08 04 04 --



80°

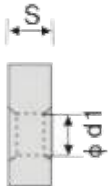

длина режущей кромки, l

толщина, S

радиус скругления режущей кромки, r

код стружколома

WN __	0604 __	0804 __	1006 __	1306 __
Ø d1 (мм)	3.81	5.16	6.35	7.93

Отрицательная геометрия ● в наличии ○ под заказ

Форма СМП	Модель	Размеры					P					M			K					
		L	Ø I.C	S	Ø L1	r	LF9008	LF9018	LF9028	LF9218	LF9118	LF918	LF6008	LF6018	LF6028	LF6118	LF618	LF3018	LF3028	
	WNUMG080408-HS	8.7	12.7	4.76	5.16	0.8														
	WNUMG080404-MT	8.7	12.7	4.76	3.81	0.4														
	WNUMG080408-MT	8.7	12.7	4.76	3.81	0.8														
	WNUMG080412-MT	8.7	12.7	4.76	5.16	1.2														
	WNUMG080404-MA	8.7	12.7	4.76	5.16	0.4						●	●							
	WNUMG080408-MA	8.7	12.7	4.76	5.16	0.8						●	●							
	WNUMG080412-MA	8.7	12.7	4.76	5.16	1.2						●	●							
	WNUMG080404-MA	8.7	12.7	4.76	5.16	0.4													●	
	WNUMG080408-MA	8.7	12.7	4.76	5.16	0.8													●	
	WNUMG080404-MA	8.7	12.7	4.76	5.16	0.4														●
	WNUMG080408-MA	8.7	12.7	4.76	5.16	0.8														●
	WNUMG080404-MM	8.7	12.7	4.76	5.16	0.4														●
	WNUMG080408-MM	8.7	12.7	4.76	5.16	0.8														●
	WNUMG080404-MM	8.7	12.7	4.76	5.16	0.4														●
	WNUMG080408-MM	8.7	12.7	4.76	5.16	0.8														●
	WNUMG080404-MS	8.7	12.7	4.76	5.16	0.4						●	●							
	WNUMG080408-MS	8.7	12.7	4.76	5.16	0.8						●	●							
	WNUMG080412-MS	8.7	12.7	4.76	5.16	1.2						●	●							
	WNUMG080404-MS	8.7	12.7	4.76	5.16	0.4														●
	WNUMG080404-MS	8.7	12.7	4.76	5.16	0.8														●

WNMG 08 04 04 --

длина режущей кромки, l толщина, S радиус скругления режущей кромки, r код стружколома

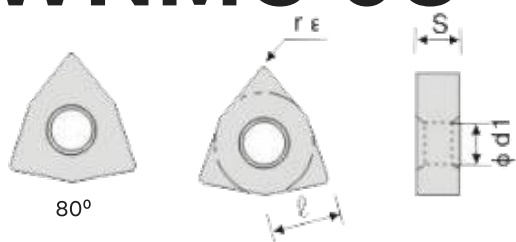

WN__	0604__	0804__	1006__	1306__
Ø d1 (мм)	3.81	5.16	6.35	7.93

Отрицательная геометрия ● в наличии ○ под заказ

Форма СМП	Модель	Размеры					P		M		K										
		L	Ø I.C	S	Ø L1	r	LF9008	LF9018	LF9028	LF9218	LF9118	LF918	LF6008	LF6018	LF6028	LF6118	LF618	LF3018	LF3028		
	WNMG080404-MS	8.7	9.525	4.76	3.81	0.4														●	
	WNMG080408-MS	8.7	9.525	4.76	3.81	0.8														●	
	WNMG080404-JMS	8.7	12.7	4.76	5.16	0.4														●	
	WNMG080408-JMS	8.7	12.7	4.76	5.16	0.8														●	
	WNMG080404-JMS	8.7	12.7	4.76	5.16	0.4														●	
	WNMG080408-JMS	8.7	12.7	4.76	5.16	0.8														●	
	WNMG080404-MS	8.7	12.7	4.76	5.16	0.4														●	
	WNMG080408-MS	8.7	12.7	4.76	5.16	0.8														●	
	WNMG060412-MS	8.7	12.7	4.76	5.16	1.2														●	
	WNMG060404	8.7	12.7	4.76	5.16	0.4														●	
	WNMG080408	8.7	12.7	4.76	5.16	0.8														●	
	WNMG080412	8.7	12.7	4.76	5.16	1.2														●	

VNMG 16 04 04 --

длина режущей кромки, l толщина, S радиус скругления режущей кромки, r код стружколома

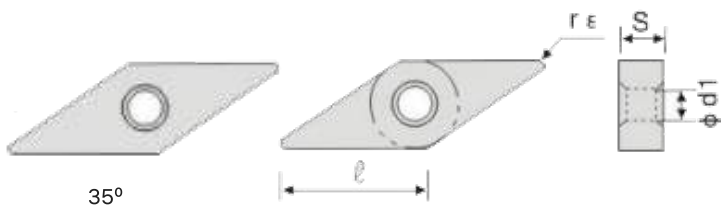

35°

VN __	1604 __
Ø d1 (мм)	3.81

Отрицательная геометрия ● в наличии ○ под заказ

Форма СМП	Модель	Размеры					P						M			K			
		L	Ø I.C	S	Ø L1	r	LF9008	LF9018	LF9028	LF9218	LF9118	LF918	LF6008	LF6018	LF6028	LF6118	LF618	LF3018	LF3028
	VNMG160404-TM	16.6	9.525	4.76	3.81	0.4	●	●											
	VNMG160408-TM	16.6	9.525	4.76	3.81	0.8	●	●											
	VNMG160412-TM	16.6	9.525	4.76	3.81	1.2	○	○											
	VNMG160404-TM	16.6	9.525	4.76	3.81	0.4				●									
	VNMG160408-TM	16.6	9.525	4.76	3.81	0.8				●									
	VNMG160412-TM	16.6	9.525	4.76	3.81	1.2				○									
	VNMG160404-MS	16.6	9.525	4.76	3.81	0.4						●	●						
	VNMG160408-MS	16.6	9.525	4.76	3.81	0.8						●	●						
	VNMG160404-HA	16.6	9.525	4.76	3.81	0.4						●	●						
	VNMG160408-HA	16.6	9.525	4.76	3.81	0.8						●	●						
	VNMG160404-HS	16.6	9.525	4.76	3.81	0.4						●	●						
	VNMG160408-HS	16.6	9.525	4.76	3.81	0.8						●	●						
	VNMG160404-MS	16.6	9.525	4.76	3.81	0.4													●
	VNMG160408-MS	16.6	9.525	4.76	3.81	0.8													●
	VNMG160404	16.6	9.525	4.76	3.81	0.4													●
	VNMG160408	16.6	9.525	4.76	3.81	0.8													●

длина режущей кромки, l толщина, S радиус скругления режущей кромки, r код стружколома

CNGA 12 04 04 --

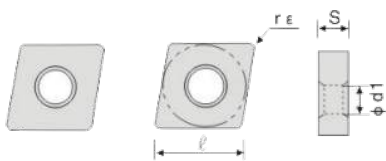

80°

CN __	0903 __	1204 __	1606 __	1906 __	2509 __
∅ d1 (мм)	3.81	5.16	6.35	7.93	9.12

Отрицательная геометрия ● в наличии ○ под заказ

Форма СМП	Модель	Размеры					Керметы	
		L	∅ I.C	S	∅ d	r	LF80	LF70
	CNGA120404	12.7	12.7	4.76	5.16	0.4		●
	CNGA120408	12.7	12.7	4.76	5.16	0.8		●
	CNGA120412	12.7	12.7	4.76	5.16	1.2		
	CNGA120404	12.7	12.7	4.76	5.16	0.4	●	
	CNGA120408	12.7	12.7	4.76	5.16	0.8	●	
	CNGA120412	12.7	12.7	4.76	5.16	1.2		

длина режущей кромки, l толщина, S радиус скругления режущей кромки, r код стружколома

TNGA 16 04 04 --

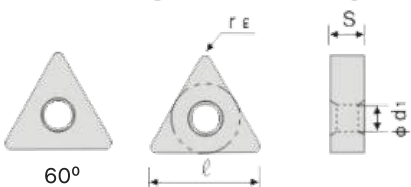

60°

TN __	1103 __	1603 __	1604 __	2204 __
∅ d1 (мм)	2.26	3.81	3.81	5.16

Отрицательная геометрия ● в наличии ○ под заказ

Форма СМП	Модель	Размеры					Керметы	
		L	∅ I.C	S	∅ d	r	LF80	LF70
	TNGA160402	16.5	9.525	4.76	3.81	0.2		
	TNGA160404	16.5	9.525	4.76	3.81	0.4		●
	TNGA160408	16.5	9.525	4.76	3.81	0.8		●
	TNGA160402	16.5	9.525	4.76	3.81	0.2		
	TNGA160404	16.5	9.525	4.76	3.81	0.4	●	
	TNGA160408	16.5	9.525	4.76	3.81	0.8	●	

VNGA 16 04 04 --

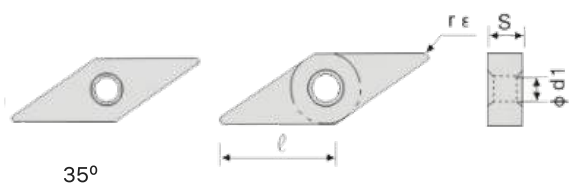

VN __	1604 __
Ø d1 (мм)	3.81

Отрицательная геометрия ● в наличии ○ под заказ

Форма СМП	Модель	Размеры					Керметы	
		L	Ø I.C	S	Ø d	r	LF80	LF70
	VNGA160402	16.6	9.525	4.76	3.81	0.2		
	VNGA160404	16.6	9.525	4.76	3.81	0.4	●	
	VNGA160408	16.6	9.525	4.76	3.81	0.8	●	
	VNGA160402	16.6	9.525	4.76	3.81	0.2		
	VNGA160404	16.6	9.525	4.76	3.81	0.4		●
	VNGA160408	16.6	9.525	4.76	3.81	0.8		●

WNGA 08 04 04 --

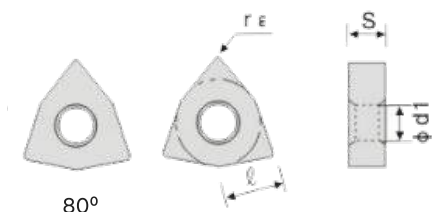

WN __	0604 __	0804 __	1006 __	1306 __
Ø d1 (мм)	3.81	5.16	6.35	7.93

Отрицательная геометрия ● в наличии ○ под заказ

Форма СМП	Модель	Размеры					Керметы	
		L	Ø I.C	S	Ø d	r	LF80	LF70
	WNGA080404	8.7	12.7	4.76	5.16	0.4		●
	WNGA080408	8.7	12.7	4.76	5.16	0.8		●
	WNGA080412	8.7	12.7	4.76	5.16	1.2		
	WNGA080404	8.7	12.7	4.76	5.16	0.4	●	
	WNGA080408	8.7	12.7	4.76	5.16	0.8	●	
	WNGA080412	8.7	12.7	4.76	5.16	1.2		

CCMT 06 02 02 --

длина режущей кромки, l толщина, S радиус скругления режущей кромки, r код стружколома

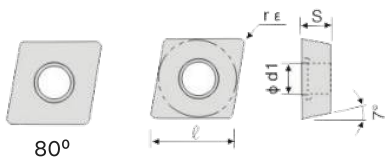

CC_T(W)	09T3__	1204__	1606__	1906__	2509__
∅ d1 (мм)	3.81	5.16	6.35	7.93	9.12

Положительная геометрия ● в наличии ○ под заказ

Форма СМП	Модель	Размеры					P			M			K						
		L	∅ l.c	S	∅ d	r	LF9008	LF9018	LF9028	LF9218	LF9118	LF918	LF6008	LF6018	LF6028	LF6118	LF618	LF3018	LF3028
	CCMT060202	6.4	6.35	2.38	2.8	0.2							●	●					
	CCMT060204	6.4	6.35	2.38	2.8	0.4							●	●					
	CCMT060208	6.4	6.35	2.38	2.8	0.8							●	●					
	CCMT09T302	9.7	9.525	3.97	4.4	0.2							●	●					
	CCMT09T304	9.7	9.525	3.97	4.4	0.4							●	●					
	CCMT09T308	9.7	9.525	3.97	4.4	0.8							●	●					
	CCMT120404	12.9	12.7	4.76	5.56	0.4							●	●					
	CCMT120408	12.9	12.7	4.76	5.56	0.8							●	●					

DCMT 07 02 02 --

длина режущей кромки, l толщина, S радиус скругления режущей кромки, r код стружколома

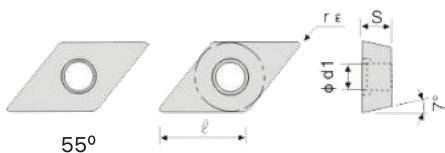

DC_T(W)	0702__	11T3__
∅ d1 (мм)	2.8	4.4

Положительная геометрия ● в наличии ○ под заказ

Форма СМП	Модель	Размеры					P			M			K						
		L	∅ l.c	S	∅ d	r	LF9008	LF9018	LF9028	LF9218	LF9118	LF918	LF6008	LF6018	LF6028	LF6118	LF618	LF3018	LF3028
	DCMT070202-HMP	7.8	6.35	2.38	2.8	0.2							●	●					
	DCMT070204-HMP	7.8	6.35	2.38	2.8	0.4							●	●					
	DCMT070208-HMP	7.8	6.35	2.38	2.8	0.8							●	●					
	DCMT11T302-HMP	11.6	9.525	3.97	4.4	0.2							●	●					
	DCMT11T304-HMP	11.6	9.525	3.97	4.4	0.4							●	●					
	DCMT11T308-HMP	11.6	9.525	3.97	4.4	0.8							●	●					

длина режущей кромки, l толщина, S радиус скругления режущей кромки, r код стружколома

SCMT 12 04 04 --

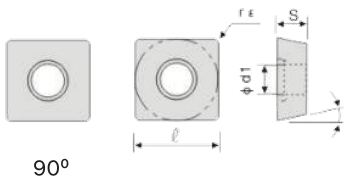

SC_T(W)	0702__	09T3__	1204__
Ø d1 (мм)	3.81	5.16	6.35

Положительная геометрия ● в наличии ○ под заказ

Форма СМП	Модель	Размеры					P			M			K							
		L	Ø I.C	S	Ø d	r	LF9008	LF9018	LF9028	LF9218	LF9118	LF918	LF6008	LF6018	LF6028	LF6118	LF618	LF3018	LF3028	
	SCMT09T304-HMP	9.525	9.525	3.97	4.4	0.4														
	SCMT09T308-HMP	9.525	9.525	3.97	4.4	0.8														

длина режущей кромки, l толщина, S радиус скругления режущей кромки, r код стружколома

TCMT 09 02 02 --

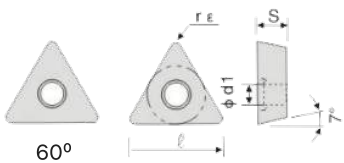

TC_T	0801__	0802__J08	0902__	1102__	16T3__
Ø d1 (мм)	2.7	2.3	2.5	2.8	4.4

Положительная геометрия ● в наличии ○ под заказ

Форма СМП	Модель	Размеры					P			M			K							
		L	Ø I.C	S	Ø d	r	LF9008	LF9018	LF9028	LF9218	LF9118	LF918	LF6008	LF6018	LF6028	LF6118	LF618	LF3018	LF3028	
	TCMT090204	9.6	5.56	2.38	2.5	0.4														
	TCMT090208	9.6	5.56	2.38	2.5	0.8														
	TCMT110202	11	6.35	2.38	2.8	0.2														
	TCMT110204	11	6.35	2.38	2.8	0.4														
	TCMT110208	11	6.35	2.38	2.8	0.8														
	TCMT16T304	16.5	9.525	3.97	4.4	0.4														
	TCMT16T308	16.5	9.525	3.97	4.4	0.8														

TPGH___-F

Положительная геометрия ● в наличии ○ под заказ

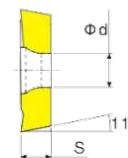
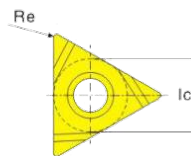
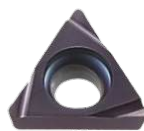

Модель	Размеры				P			M			K		Без покрытия					
	I.C	S	d	r	LF9008	LF9018	LF9028	LF9218	LF9118	LF918	LF6008	LF6018		LF6028	LF6118	LF618	LF3018	LF3028
TPGH080201L-F	4.76	2.38	2.3	0.1							●							
TPGH080202L-F	4.76	2.38	2.3	0.2							●							
TPGH080204L-F	4.76	2.38	2.3	0.4							●							
TPGH090201L-F	5.56	2.38	3.2	0.1							●							
TPGH090202L-F	5.56	2.38	3.2	0.2							●							
TPGH090204L-F	5.56	2.38	3.2	0.4							●							
TPGH110202L-F	6.35	3.18	3.3	0.2							●							
TPGH110204L-F	6.35	3.18	3.3	0.4							●							

TBMT___-DP

Положительная геометрия ● в наличии ○ под заказ

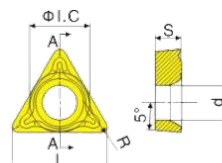

Модель	Размеры					P			M			K		Без покрытия					
	L	I.C	S	d	r	LF9008	LF9018	LF9028	LF9218	LF9118	LF918	LF6008	LF6018		LF6028	LF6118	LF618	LF3018	LF3028
TBMT060104-DP	6.0	3.97	1.58	2.3	0.4							●							

WBMT___-DP

Положительная геометрия ● в наличии ○ под заказ

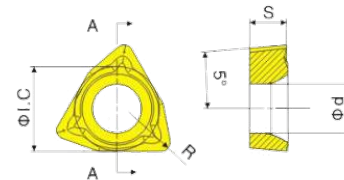

Модель	Размеры					P			M			K		Без покрытия					
	L	I.C	S	d	r	LF9008	LF9018	LF9028	LF9218	LF9118	LF918	LF6008	LF6018		LF6028	LF6118	LF618	LF3018	LF3028
WBMT060104L-DP	6	3.97	1.62	2.35	0.4							●							

VBMT 11 03 02 --

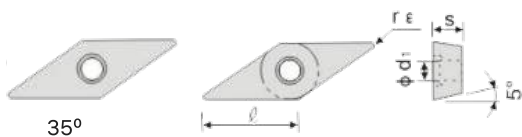

VB_T	1103 __	1604 __
∅ d1 (мм)	2.8	4.4

Положительная геометрия ● в наличии ○ под заказ

Форма СМП	Модель	Размеры					P		M		K									
		L	∅ I.C	S	∅ d	r	LF9008	LF9018	LF9028	LF9218	LF9118	LF918	LF6008	LF6018	LF6028	LF6118	LF618	LF3018	LF3028	
	VBMT110302-MV	11	6.35	3.18	2.8	0.2														
	VBMT110304-MV	11	6.35	3.18	2.8	0.4														
	VBMT110308-MV	11	6.35	3.18	2.8	0.8														
	VBMT160404-MV	16.5	9.525	4.76	4.4	0.4														
	VBMT160408-MV	16.5	9.525	4.76	4.4	0.8														

VCMT 11 03 02 --



VC_T	0802 __	1103 __	1604 __	2205 __
∅ d1 (мм)	2.3	2.8	4.4	5.5









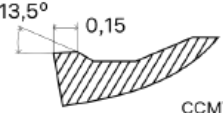

Положительная геометрия ● в наличии ○ под заказ

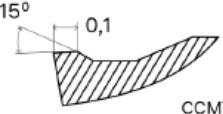
Форма СМП	Модель	Размеры					P		M		K									
		L	∅ I.C	S	∅ d	r	LF9008	LF9018	LF9028	LF9218	LF9118	LF918	LF6008	LF6018	LF6028	LF6118	LF618	LF3018	LF3028	
	VCMT110304-MV	11	6.35	3.18	2.8	0.4														
	VCMT160404-MV	16	9.525	4.76	4.4	0.4														
	VCMT160408-MV	16	9.525	4.76	4.4	0.8														

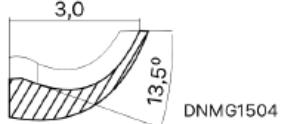
Пластины для токарной обработки

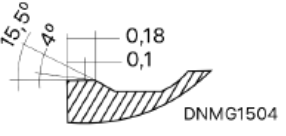
Класс	Основной компонент	Плотность (г/см ³)	Твердость (HRA)	Прочность на изгиб(МПа)	Упругость (МПа × м ^{0,5})	Область применения
LF90	TiCN+NbC	6,65	92,5	1 800	7.30	Чистовая и получистовая обработка углеродистой, легированной, низкоуглеродистой стали и чугуна. Прецизионная обработка. Общая токарная и фрезерная обработка.

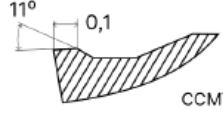
Геометрия пластин для токарной обработки

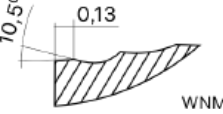
Название и геометрический угол			Применение и характеристики
MT		 CCMT09T3	<ul style="list-style-type: none"> - Получистовая обработка - Сталь, нержавеющая сталь и чугун - Универсальный передний угол
FG		 CCMT09T3	<ul style="list-style-type: none"> - Чистовая обработка - Сталь, нержавеющая сталь и чугун - Низкая сила резания
R-VF		 DNMG1504	<ul style="list-style-type: none"> - Черновая и тяжелая черновая обработка - Сталь и нержавеющая сталь - Большой передний угол
R-S		 DNMG1504	<ul style="list-style-type: none"> - Получистовая обработка - Сталь и нержавеющая сталь - Большой передний угол
TC		 CCMT09T3	<ul style="list-style-type: none"> - Универсальное применение - Сталь и нержавеющая сталь - Хорошее удаление стружки
TS		 WNMG0804	<ul style="list-style-type: none"> • Чистовая обработка • Сталь • Острая режущая кромка



CN _ _

Отрицательная геометрия

Форма СМП	Модель	Размеры					Класс
		L	D	S	d1	R	LF90
	CNMG120404-MT	12.9	12.7	4.76	5.16	0.4	
	CNMG120408-MT	12.9	12.7	4.76	5.16	0.8	

CC _ _

Положительная геометрия

Форма СМП	Модель	Размеры					Класс
		L	D	S	d1	R	LF90
	CCMT060204-FG	6.5	6.35	2.38	2.8	0.4	
	CCMT09T304-FG	9.7	9.525	3.97	4.4	0.4	
	CCMT09T308-FG	9.7	9.525	3.97	4.4	0.8	
	CCMT060204-MT	6.5	6.35	2.38	2.8	0.4	
	CCMT09T304-MT	9.7	9.525	3.97	4.4	0.4	
	CCMT09T308-MT	9.7	9.525	3.97	4.4	0.8	
	CCMT09T304-TC	9.7	9.525	3.97	4.4	0.4	
	CCMT09T308-TC	9.7	9.525	3.97	4.4	0.8	

DN _ _

Отрицательная геометрия

Форма СМП	Модель	Размеры					Класс
		L	D	S	d1	R	LF90
	DNMG150404-MT	15.5	12.7	4.76	5.16	0.4	
	DNMG150408-MT	15.5	12.7	4.76	5.16	0.8	
	DNMG150404L/R-VF	15.5	12.7	4.76	5.16	0.4	
	DNMG150404L/R-VF	15.5	12.7	4.76	5.16	0.8	

DC

Положительная геометрия

Форма СМП	Модель	Размеры					Класс
		L	D	S	d1	R	LF90
	DCMT070204-FG	7.8	6.35	2.38	2.8	0.4	
	DCMT11T304-FG	11.6	9.525	3.97	4.4	0.4	
	DCMT11T308-FG	11.6	9.525	3.97	4.4	0.8	
	DCMT11T304-MT	11.6	9.525	3.97	4.4	0.4	
	DCMT11T308-MT	11.6	9.525	3.97	4.4	0.8	

SC

Положительная геометрия

Форма СМП	Модель	Размеры					Класс
		L	D	S	d1	R	LF90
	SCMT09T304-MT	9.525	9.525	3.97	4.4	0.4	

TC

Положительная геометрия

Форма СМП	Модель	Размеры					Класс
		L	D	S	d1	R	LF90
	TCMT090204-MT	9.6	5.56	2.38	2.5	0.4	
	TCMT110202-MT	11	6.35	2.38	2.8	0.2	
	TCMT110204-MT	11	6.35	2.38	2.8	0.4	







TP

Положительная геометрия

Форма СМП	Модель	Размеры					Класс
		L	D	S	d1	R	LF90
	TPMT110304-FG	11	6.35	2.38	2.8	0.4	

TN

Отрицательная геометрия

Форма СМП	Модель	Размеры					Класс
		L	D	S	d1	R	LF90
	TNGG160402R-F	16.5	9.525	4.76	3.81	0.2	●
	TNGG160404R-F	16.5	9.525	4.76	3.81	0.4	●
	TNGG160408R-F	16.5	9.525	4.76	3.81	0.8	●
	TNGG160402L-F	16.5	9.525	4.76	3.81	0.2	●
	TNGG160404L-F	16.5	9.525	4.76	3.81	0.4	●
	TNGG160408L-F	16.5	9.525	4.76	3.81	0.8	●
	TNGG160402R-C	16.5	9.525	4.76	3.81	0.2	●
	TNGG160404R-C	16.5	9.525	4.76	3.81	0.4	●
	TNGG160408R-C	16.5	9.525	4.76	3.81	0.8	●
	TNGG160402L-C	16.5	9.525	4.76	3.81	0.2	●
	TNGG160404L-C	16.5	9.525	4.76	3.81	0.4	●
	TNGG160408L-C	16.5	9.525	4.76	3.81	0.8	●
	TNGG160402R-P	16.5	9.525	4.76	3.81	0.2	●
	TNGG160404R-P	16.5	9.525	4.76	3.81	0.4	●
	TNGG160408R-P	16.5	9.525	4.76	3.81	0.8	●
	TNGG160402L-P	16.5	9.525	4.76	3.81	0.2	●
	TNGG160404L-P	16.5	9.525	4.76	3.81	0.4	●
	TNGG160408L-P	16.5	9.525	4.76	3.81	0.8	●



VN

Отрицательная геометрия

Форма СМП	Модель	Размеры					Класс
		L	D	S	d1	R	LF90
	VNMG160404-MT	16.6	9.525	4.76	3.81	0.4	
	VNMG160408-MT	16.6	9.525	4.76	3.81	0.8	



TN _ _

Положительная геометрия

Форма СМП	Модель	Размеры					Класс
		L	D	S	d1	R	LF90
	TNMG160404-MT	16.5	9.525	4.76	3.81	0.4	
	TNMG160408-MT	16.5	9.525	4.76	3.81	0.8	
	TNMG160404L-VF	16.5	9.525	4.76	3.81	0.4	
	TNMG160404R-VF	16.5	9.525	4.76	3.81	0.4	
	TNMG160408L-VF	16.5	9.525	4.76	3.81	0.8	
	TNMG160408R-VF	16.5	9.525	4.76	3.81	0.8	
	TNMG160404L-S	16.5	9.525	4.76	3.81	0.4	
	TNMG160404R-S	16.5	9.525	4.76	3.81	0.4	
	TNMG160408L-S	16.5	9.525	4.76	3.81	0.8	
	TNMG160408R-S	16.5	9.525	4.76	3.81	0.8	

WN _ _

Отрицательная геометрия

Форма СМП	Модель	Размеры					Класс
		L	D	S	d1	R	LF90
	WNMG080404-MT	8.7	12.7	4.76	5.16	0.4	
	WNMG080408-MT	8.7	12.7	4.76	5.16	0.8	
	WNMG080404-TS	8.7	12.7	4.76	5.16	0.4	
	WNMG080404-TC	8.7	12.7	4.76	5.16	0.4	

Пластины для токарной обработки

Рекомендованные параметры обработки

Модель		Рекомендуемые параметры резания		Скорость резания
		Подача (мм/об)	Глубина резания (мм)	LF90
CNMG	120404 MT	0.15-0.40	1.0-4.0	280 220
	120408 MT	0.17-0.55	1.2-4.5	
	120404 TC	0.15-0.40	0.5-3.5	310 140
DNMG	150404 MT	0.15-0.40	0.8-3.5	280 220
	150404 R-VF	0.10-0.35	0.7-4.0	310
	150404 R-S	0.20-0.40	1.5-4.0	
TNMG	160404 MT	0.17-0.35	1.0-3.0	280 220
	160408 MT	0.17-0.35	1.2-3.5	
	160404 R-VF	0.10-0.30	0.7-3.0	
	160404 R-S	0.15-0.30	1.0-3.0	310
	160404 L-S	0.15-0.30	0.8-3.0	
	160404 TC	0.15-0.40	1.5-3.5	310 140
VNMG	160404 MT	0.15-0.36	0.8-2.5	
	160408 MT	0.17-0.36	1.0-2.5	280 220
WNMG	060404 FG	0.07-0.20	0.5-2.0	310 230
	080404 MT	0.12-0.40	1.0-3.5	280 220
	080408 MT	0.17-0.55	1.2-3.5	
	080404 TS	0.08-0.20	0.3-1.5	280
	080404 TC	0.15-0.30	1.5-3.5	310 140
CCMT	060202 FG	0.10-0.25	0.6-2.4	320
	060204 FG	0.05-0.15	0.3-1.5	310 230
	060204 MT	0.07-0.20	0.5-2.0	280 210
	09T304 MT	0.10-0.25	0.7-3.0	
	09T304 FG	0.07-0.20	0.4-2.0	310 230
	09T304 TC	0.08-0.3	0.5-3.0	280
DCMT	070204 FG	0.08-0.20	0.4-1.5	
	11T304 FG	0.10-0.25	0.6-1.5	310 240
	11T304 MT	0.10-0.25	0.7-3.0	
SCMT	09T304 MT	0.10-0.25	0.7-3.0	280 210
TCMT	090204 MT	0.10-0.25	0.6-2.0	280 210
	110204 MT	0.10-0.25	0.6-2.5	
TPMT	110304 FG	0.07-0.20	0.4-1.5	310 230

Геометрия стружколома

MGM (G)N - M



Специально разработанный стружколом обеспечивает более плавный отвод стружки по сравнению с обычной геометрией с плоским верхом благодаря использованию центрального стружколома

Специальные выступы способствуют плавному отводу стружки при наружной обработке

Стружколом предназначен для точения и обработки канавок

MGMN - G



Специально разработанный стружколом позволяет дробить стружку на узкие элементы, улучшая тем самым отвод стружки

Высокая эффективность применения при точении канавок

MRMN - M



Геометрия с полным радиусом для профилирования

Специальная геометрия для обработки фасонных профилей

Точение и обработка канавок

ВЫБОР ПЛАСТИНЫ

Скорость подачи - величина, определяющая максимальную скорость подачи, должна учитывать характеристики пластины и производительность станка.

$$(F_{\max} = W \times 0,075)$$

Максимальная скорость подачи не может превышать радиус R угла пластины

При обработке канавок проблема удаления стружки может быть решена поэтапной обработкой с малой глубиной резания.

ГЛУБИНА РЕЗАНИЯ - минимальная глубина резания не должна быть меньше радиуса вершины пластины.

Максимальная глубина резания зависит от режущей нагрузки станка.

Использование различных форм пластин может улучшить отклонение и задний угол обрабатываемых деталей.

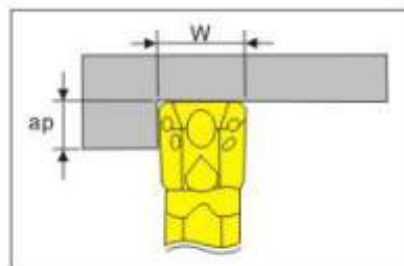
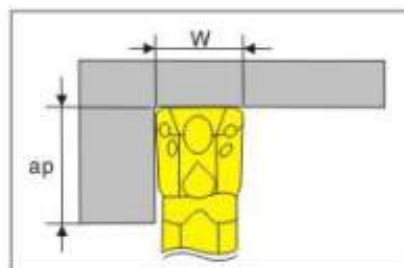

ОСОБЫЕ УКАЗАНИЯ ПРИ ТОЧЕНИИ

Конструкция инструмента MGT позволяет ему создавать боковое усилие резания за счет заднего угла между пластинами, что делает его более выгодным по сравнению со стандартными лезвиями ISO.

Стандартные пластины MGT обладают сглаживающим эффектом для улучшения шероховатости поверхности.

Особые указания при обработке

ОСОБЫЕ УКАЗАНИЯ ПРИ ЧИСТОВОЙ ОБРАБОТКЕ

После обработки канавки в радиальном направлении до окончательного диаметра, поперечное перемещение режущего инструмента в осевом направлении может привести к фактическому отклонению размера канавки по сравнению с заданным по чертежу. В этом случае сместите траекторию обработки в соответствии с формулой

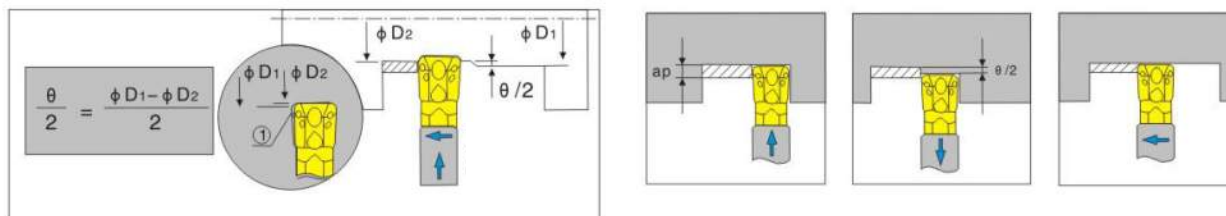

Используйте задний угол, чтобы устранить отклонение обрабатываемой заготовки (обычно возникающее после чистового прохода), в направлении, показанном на рисунке выше. Чтобы получить отличную шероховатость поверхности и отсутствие отклонений, перемещайте инструмент следующих направлениях:

1. Нарезание канавок до конечного диаметра
2. Расстояние отвода инструмента составляет $\theta/2$
3. Непрерывное боковое точение до конечного диаметра

ОСОБЫЕ УКАЗАНИЯ ПО ПРИМЕНЕНИЮ МНОГОФУНКЦИОНАЛЬНОГО ИНСТРУМЕНТА MGT

Как многофункциональный инструмент MGT можно использоваться для обработки канавок и точения. При использовании инструмента имейте ввиду, что он имитирует применение стандартной обработки ISO, в которой используется положительный задний угол, поэтому сила и глубина резания реализуются одновременно.

Это приведет к определенному износу пластины, и после точения процесс нарезания канавок не достигнет конечного требуемого диаметра. Для устранения отклонения диаметра инструмент перемещается вправо на 0,1 мм, а затем возвращается в исходное положение для нарезания канавок.

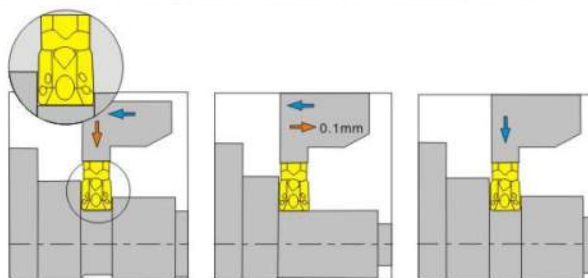

РАДИУС ЗАКРУГЛЕНИЯ УГЛОВ ОБРАБАТЫВАЕМОЙ ДЕТАЛИ МЕНЬШЕ РАДИУСА ВЕРШИНЫ ПЛАСТИНЫ

При нарезании канавки, если радиус закругленных углов обрабатываемой детали больше, чем радиус вершины пластины, при стабильном сопротивлении резанию инструмент создаст синтетическую нагрузку (как показано на рисунке).

Несбалансированное резание в направлении радиальной глубины резания и осевой глубины резания, нагрузка приведет к повреждению лезвия и держателя инструмента.

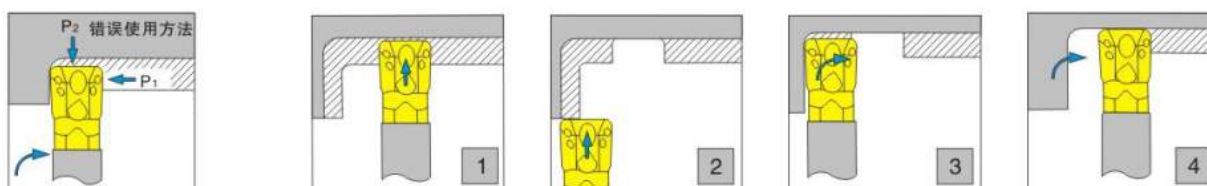

Отрезание и поперечное точение канавок

ПЛАСТИНА

Выбор угла μ

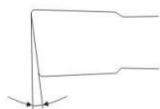

- 4° - трубы, полые заготовки
- 6° - трубы и прутки
- 8° - прутки
- 15° - прутки малого диаметра

Отрезание прутков



- Отрезание прутков
- Удаление остаточного стержня
- Уменьшение вероятности увода инструмента
- Возможность отрезания больших диаметров заготовки

$\mu = 4^\circ \sim 8^\circ$



- Уменьшение размера остаточного стержня при разрезании прутков
- Уменьшение вибраций при разрезании труб и полых заготовок

$\mu = 8^\circ \sim 15^\circ$



- Применяется для обработки малых диаметров прутков и пустотелых заготовок
- Способствует снижению вибрации

ВЫБОР ПЛАСТИНЫ

Для оптимального выбора пластины необходимо, чтобы все ее параметры строго соответствовали условиям обработки.

Необходимо учесть:

1. Ширину пластины
2. Стружколом
3. Радиус при вершине

Соотношение между шириной пластины и глубиной канавки.

Для глубоких канавок, как правило, выбирают пластину с $\alpha = 0^\circ$. Для обработки углеродистых сталей глубина канавки = $W \cdot 0,8$.

Выбор угла ρ .

Для уменьшения заусенцев мы рекомендуем использовать пластину с углом в плане. Пластины с более высокими углами в плане снижают образование заусенцев и срок службы инструмента. В тех случаях, когда заусенцы допустимы, мы рекомендуем использовать нейтральную пластину.



ТОЧНОСТЬ ПОЗИЦИОНИРОВАНИЯ ДЕРЖАВКИ

Для повышения эффективности работы, снижения вероятности поломки инструмента и уменьшения вибраций, необходимо, чтобы направление подачи было строго перпендикулярно оси заготовки.

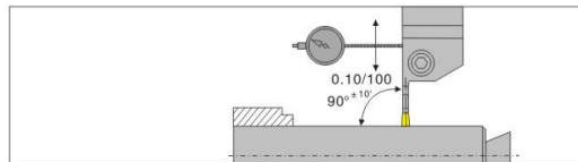

УСТАНОВКА ИНСТРУМЕНТА ОТНОСИТЕЛЬНО ВЫСОТЫ ЦЕНТРА ЗАГОТОВКИ

Высота режущей кромки пластины при отрезании должна совпадать с осью заготовки с точностью $\pm 0,1$ мм. Для уменьшения вибрации необходимо закреплять заготовку как можно ближе к зажимному патрону или цанге.

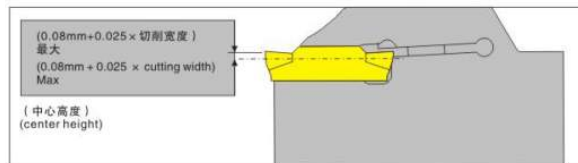

ОБЩИЕ РЕКОМЕНДАЦИИ ДЛЯ ОТРЕЗНЫХ ОПЕРАЦИЙ

Применяйте оптимальную подачу и скорость резания. Используйте обильную подачу СОЖ. Перед очередной заменой пластины (грани) тщательно очистите от стружки и грязи посадочное гнездо.

ПРЕДОСТРЕЖЕНИЯ

Запрещается работать пластинами, достигшими критического износа, так как можно при этом испортить заготовку. При значительном износе посадочного места, державку следует заменить на новую. Посадочные места под пластины на державках не ремонтируются.

ВЫБОР СТРУЖКОЛОМА

Все стружколомы выпускаемые нами предусматривают дробление стружки на узкие элементы, что обеспечивает следующие преимущества:

Уменьшается вероятность контакта стружки и обработанной поверхности, что улучшает качество обработанной поверхности. Повышение производительности обработки за счет возможности увеличения подач при незначительном возрастании силы резания. Это обусловлено положительной геометрией режущей кромки ведущей к уменьшению нагрузки.

MGMN __ -G

● в наличии ○ под заказ

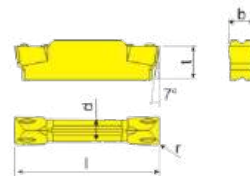

Твердый сплав с покрытием

Модель	Размеры					Твердый сплав с покрытием													
	b	r	l	d	t	P			M			K	LDA						
						LF9008	LF9018	LF9028	LF9218	LF9118	LF918	LF6008	LF6018	LF6028	LF6118	LF618	LF3018	LF3028	
MGMN150-G	1.5	0.15	16	1.2	3.5	●						●							●
MGMN200-G	2	0.2	16	1.6	3.5	●						●							●
MGMN250-G	2.5	0.2	18.5	2	3.85	●						●							●

MGMN __ -M

● в наличии ○ под заказ

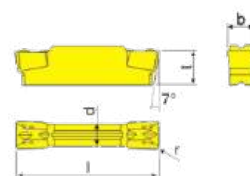

Твердый сплав с покрытием

Модель	Размеры					Твердый сплав с покрытием													
	b	r	l	d	t	P			M			K	LDA						
						LF9008	LF9018	LF9028	LF9218	LF9118	LF918	LF6008	LF6018	LF6028	LF6118	LF618	LF3018	LF3028	
MGMN300-M	3	0.4	21	2.35	4.8	●						●	●						●
MGMN400-M	4	0.4	21	3.3	4.8	●						●	●						●
MGMN500-M	5	0.4	26	4.1	5.8	●						●	●						●
MGMN600-M	6	0.8	26	5	5.8	○						○	○						○

MGMN __ -T

● в наличии ○ под заказ

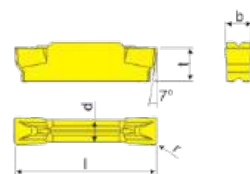

Твердый сплав с покрытием

Модель	Размеры					Твердый сплав с покрытием													
	b	r	l	d	t	P			M			K	LDA						
						LF9008	LF9018	LF9028	LF9218	LF9118	LF918	LF6008	LF6018	LF6028	LF6118	LF618	LF3018	LF3028	
MGMN200-T	2	0.2	16	1.6	3.5	●						●							●
MGMN300-T	3	0.4	21	2.35	4.8	●						●							●
MGMN400-T	4	0.4	21	3.3	4.8	●						●							●

MGMN __-H

● в наличии ○ под заказ

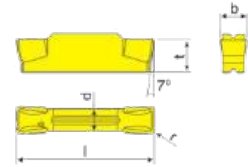

Твердый сплав с покрытием

Модель	Размеры					P			M			K		LDA					
	b	r	l	d	t	LF9008	LF9018	LF9028	LF9218	LF9118	LF918	LF6008	LF6018		LF6028	LF6118	LF618	LF3018	LF3028
MGMN400-H	4	0.4	21	3.3	4.8	●						●							●

MGGN ___-JH

● в наличии ○ под заказ

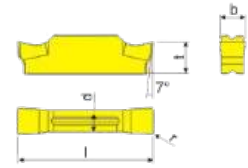

Твердый сплав с покрытием

Модель	Размеры					P			M			K		LDA					
	b	r	l	d	t	LF9008	LF9018	LF9028	LF9218	LF9118	LF918	LF6008	LF6018		LF6028	LF6118	LF618	LF3018	LF3028
MGGN150-JH	1.5	0.15	16	1.2	3.5									●					
MGGN200-JH	2	0.2	16	1.6	3.5									●					
MGGN250-JH	2.5	0.2	18.5	2	3.85									●					
MGGN300-JH	3	0.4	21	2.35	4.8									●					
MGGN400-JH	4	0.4	21	3.3	4.8									●					
MGGN500-JH	5	0.4	26	4.1	5.8									●					
MGGN600-JH	6	0.4	26	4.1	5.8									●					

MRMN __-M

● в наличии ○ под заказ

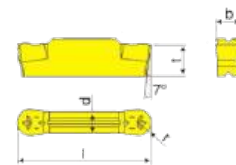

Твердый сплав с покрытием

Модель	Размеры					P			M			K		LDA					
	b	r	l	d	t	LF9008	LF9018	LF9028	LF9218	LF9118	LF918	LF6008	LF6018		LF6028	LF6118	LF618	LF3018	LF3028
MRMN200-M	2	1	16	1.6	3.5	●								●					●
MRMN300-M	3	1.5	21	2.35	4.8	●								●					●
MRMN400-M	4	2	21	3.3	4.8	●								●					●

MGGN __ -JM

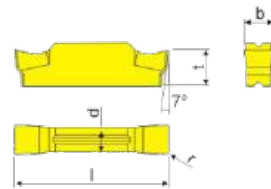

● в наличии ○ под заказ

Твердый сплав с покрытием

Модель	Размеры					P		M			K		LDA						
	b	r	l	d	t	LF9008	LF9018	LF9028	LF9218	LF9118	LF918	LF6008		LF6018	LF6028	LF6118	LF618	LF3018	LF3028
MGGN150-JM	1.5	0.15	16	1.2	3.5	●						●	●						●
MGGN200-JM	2	0.2	16	1.6	3.5	●						●	●						●
MGGN250-JM	2.5	0.2	18.5	2	3.85	●						●	●						●
MGGN300-JM	3	0.4	21	2.35	4.8	●						●	●						●
MGGN400-JM	4	0.4	21	3.3	4.8	●						●	●						●
MGGN500-JM	5	0.4	26	4.1	5.8	○						○	○						○

MGGN __ -8

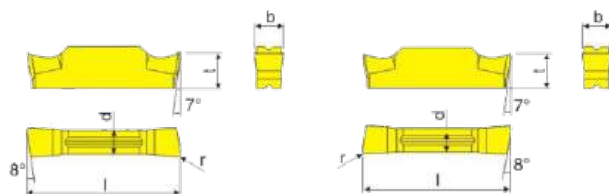

● в наличии ○ под заказ

Твердый сплав с покрытием

Модель	Размеры					P		M			K		LDA						
	b	r	l	d	t	LF9008	LF9018	LF9028	LF9218	LF9118	LF918	LF6008		LF6018	LF6028	LF6118	LF618	LF3018	LF3028
MGGN150L-8	1.5	-	16	1.2	3.5	●						●	●						●
MGGN150R-8	1.5	-	16	1.2	3.5	●						●	●						●
MGGN200L-8	2	-	16	1.6	3.5	●						●	●						●
MGGN200R-8	2	-	16	1.6	3.5	●						●	●						●
MGGN250L-8	2.5	-	18.5	2	3.85	●						●	●						●
MGGN250R-8	2.5	-	18.5	2	3.85	●						●	●						●
MGGN300L-8	3	-	21	2.35	4.8	●						●	●						●
MGGN300R-8	3	-	21	2.35	4.8	●						●	●						●
MGGN400L-8	4	-	21	3.3	4.8	●						●	●						●
MGGN400R-8	4	-	21	3.3	4.8	●						●	●						●
MGGN500L-8	5	-	26	4.1	5.8	○						○	○						○
MGGN500R-8	5	-	26	4.1	5.8	○						○	○						○

MGMN __ -G-AL

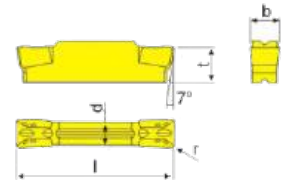

● в наличии ○ под заказ

Твердый сплав с покрытием

Модель	Размеры					P			M			K		HO1					
	b	r	l	d	t	LF9008	LF9018	LF9028	LF9218	LF9118	LF918	LF6008	LF6018		LF6028	LF6118	LF618	LF3018	LF3028
MGMN150-G-AL	1.5	0.15	16	1.2	3.5														●
MGMN200-G-AL	2	0.2	16	1.6	3.5														●
MGMN250-G-AL	2.5	0.2	18.5	2	3.85														●

MRMN __ -M-AL

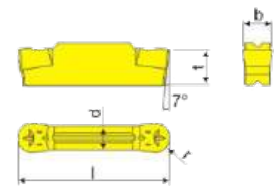

● в наличии ○ под заказ

Твердый сплав с покрытием

Модель	Размеры					P			M			K		HO1					
	b	r	l	d	t	LF9008	LF9018	LF9028	LF9218	LF9118	LF918	LF6008	LF6018		LF6028	LF6118	LF618	LF3018	LF3028
MRMN200-M-AL	2	1	16	1.6	3.5														●
MRMN300-M-AL	3	1.5	21	2.35	4.8														●
MRMN400-M-AL	4	2	21	3.3	4.8														●

СТ --- • ---

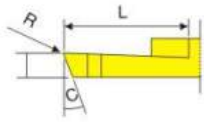
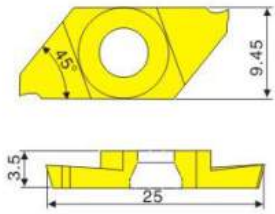

Модель	Размеры					Материал		
	R	W	L	C	max D	LF6018	LF90	LDA
СТРА0.7FR	0.05	0.7	6.5	16°	12	●		●
СТРА1.0FR		1	6.5	16°	12	●		●
СТРА1.5FR		1.5	7.5	16°	14	●		●
СТРА2.0FR		2	7.5	16°	4	●		●
СТРА0.7FRN		0.7	6.5	0	12	●		●
СТРА1.0FRN		1	6.5	0	12	●		●
СТРА1.5FRN		1.5	7.5	0	14	●		●
СТРА2.0FRN		2	7.5	0	14	●		●
СТРА0.7FL		0.7	6.5	16°	12	●		●
СТРА1.0FL		1	6.5	16°	12	●		●
СТРА1.5FL		1.5	7.5	16°	14	●		●
СТРА2.0FL		2	7.5	16°	14	●		●
СТРА0.7FLN		0.7	6.5	0	12	●		●
СТРА1.0FLN		1	6.5	0	12	●		●
СТРА1.5FLN		1.5	7.5	0	14	●		●
СТРА2.0FLN		2	7.5	0	14	●		●

СТ

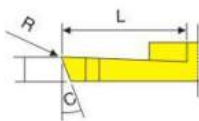
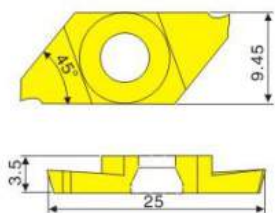

Модель	Размеры					Материал		
	R	W	L	C	max D	LF6018	LF90	LDA
СТP0.7FR	0.05	0.7	4.5	16°	8	●		●
СТP1.0FR		1	6.5	16°	12	●		●
СТP1.5FR		1.5	6.5	16°	12	●		●
СТP2.0FR		2	6.5	16°	12	●		●
СТP0.7FRN		0.7	4.5	0	8	●		●
СТP1.0FRN		1	6.5	0	12	●		●
СТP1.5FRN		1.5	6.5	0	12	●		●
СТP2.0FRN		2	6.5	0	12	●		●
СТP0.7FL		0.7	4.5	16°	8	●		●
СТP1.0FL		1	6.5	16°	12	●		●
СТP1.5FL		1.5	6.5	16°	12	●		●
СТP2.0FL		2	6.5	16°	12	●		●
СТP0.7FLN		0.7	4.5	0	8	●		●
СТP1.0FLN		1	6.5	0	12	●		●
СТP1.5FLN		1.5	6.5	0	12	●		●
СТP2.0FLN		2	6.5	0	12	●		●

GR

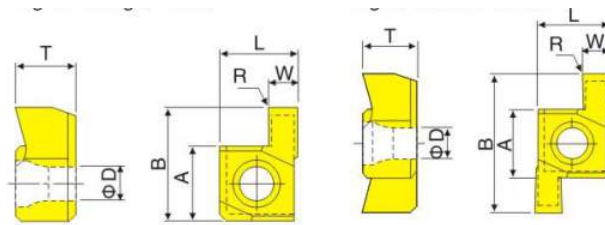

Модель	Размеры							Материал		
	W	A	B	T	ØD	L	R	LF6018	LF90	LDA
6GR/L 100	1.0	4.76	6.4	2.34	2.3	5.56	0.2	●		●
6GR/L 110	1.1							●		●
6GR/L 120	1.2							●		●
6GR/L 130	1.3							●		●
6GR/L 140	1.4							●		●
6GR/L 150	1.5							●		●
6GR/L 160	1.6							●		●
6GR/L 170	1.7							●		●
6GR/L 180	1.8							●		●
6GR/L 190	1.9							●		●
6GR/L 200	2.0							●		●
7GR/L 100	1.0	5.56	7.36	3.08	2.58	5.56		●		●
7GR/L 110	1.1							●		●
7GR/L 120	1.2							●		●
7GR/L 130	1.3							●		●
7GR/L 140	1.4							●		●
7GR/L 150	1.5							●		●
7GR/L 160	1.6							●		●
7GR/L 170	1.7							●		●
7GR/L 180	1.8							●		●
7GR/L 190	1.9							●		●
7GR/L 200	2.0						●		●	
8GR/L 100	1.0	5.56	10.16	3.87	2.58	6.15	●		●	
8GR/L 110	1.1						●		●	
8GR/L 120	1.2						●		●	
8GR/L 130	1.3						●		●	
8GR/L 140	1.4						●		●	
8GR/L 150	1.5						●		●	
8GR/L 160	1.6						●		●	
8GR/L 170	1.7						●		●	
8GR/L 180	1.8						●		●	
8GR/L 190	1.9						●		●	
8GR/L 200	2.0						●		●	
8GR/L 210	2.1						●		●	
8GR/L 220	2.2						●		●	
8GR/L 230	2.3						●		●	
8GR/L 240	2.4						●		●	
8GR/L 250	2.5						●		●	
8GR/L 260	2.6						●		●	
8GR/L 270	2.7	●		●						

GR

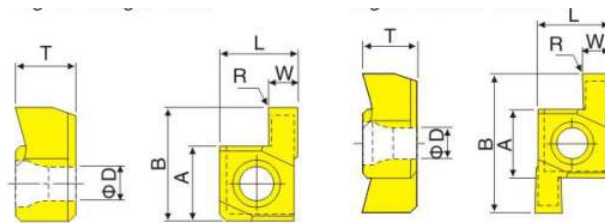

Модель	Размеры							Материал		
	W	A	B	T	ØD	L	R	LF6018	LF90	LDA
8GR/L 280	2.8	5.56	10.16	3.87	2.58	6.15		●		●
8GR/L 290	2.9							●	●	
8GR/L 300	3							●	●	
8GR/L 310	3.1							●	●	
8GR/L 320	3.2							●	●	
8GR/L 330	3.3							●	●	
8GR/L 340	3.4							●	●	
8GR/L 350	3.5							●	●	
9GR/L 100	1.0	6.35	12.95	4.66	2.86	7.74	0.2	●		●
9GR/L 110	1.0							●	●	
9GR/L 120	1.2							●	●	
9GR/L 130	1.3							●	●	
9GR/L 140	1.4							●	●	
9GR/L 150	1.5							●	●	
9GR/L 160	1.6							●	●	
9GR/L 170	1.7							●	●	
9GR/L 180	1.8							●	●	
9GR/L 190	1.9							●	●	
9GR/L 200	2.0							●	●	
9GR/L 210	2.1							●	●	
9GR/L 220	2.2							●	●	
9GR/L 230	2.3							●	●	
9GR/L 240	2.4							●	●	
9GR/L 250	2.5							●	●	
9GR/L 260	2.6							●	●	
9GR/L 270	2.7							●	●	
9GR/L 280	2.8							●	●	
9GR/L 290	2.9							●	●	
9GR/L 300	3.0							●	●	
9GR/L 310	3.1							●	●	
9GR/L 320	3.2							●	●	
9GR/L 330	3.3							●	●	
9GR/L 340	3.4							●	●	
9GR/L 350	3.5							●	●	
9GR/L 360	3.6							●	●	
9GR/L 370	3.7							●	●	
9GR/L 380	3.8							●	●	
9GR/L 390	3.9							●	●	
9GR/L 400	4.0							●	●	



TGF__R/L

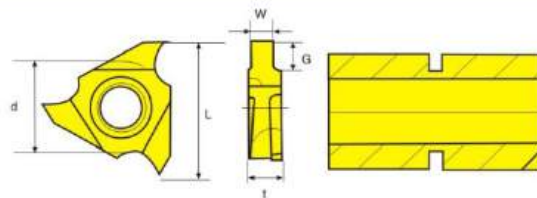

Модель	Размеры					Материал		
	L	W	G	d	t	LF6018	LF6118	LDA
TGF32R/L 030	16	0.30	0.9	3/8	3.18	●	●	●
TGF32R/L 040		0.40	1.3			●	●	●
TGF32R/L 050		0.50	1.3			●	●	●
TGF32R/L 060		0.60	1.9			●	●	●
TGF32R/L 065		0.65	1.9			●	●	●
TGF32R/L 070		0.70	1.9			●	●	●
TGF32R/L 075		0.75	1.9			●	●	●
TGF32R/L 080		0.80	1.9			●	●	●
TGF32R/L 085		0.85	1.9			●	●	●
TGF32R/L 090	16	0.90	1.9	3/8	3.18	●	●	●
TGF32R/L 095		0.95	1.9			●	●	●
TGF32R/L 100		1.00	2.3			●	●	●
TGF32R/L 110	16	1.10	2.3	3/8	3.18	●	●	●
TGF32R/L 115		1.15	2.3			●	●	●
TGF32R/L 120		1.20	2.3			●	●	●
TGF32R/L 125		1.25	2.3			●	●	●
TGF32R/L 130		1.30	2.3			●	●	●
TGF32R/L 135		1.35	2.3			●	●	●
TGF32R/L 140		1.40	2.3			●	●	●
TGF32R/L 145		1.45	2.3			●	●	●
TGF32R/L 150		1.50	2.3			●	●	●
TGF32R/L 155		1.55	2.3			●	●	●
TGF32R/L 160		1.60	2.3			●	●	●
TGF32R/L 165		1.65	2.3			●	●	●
TGF32R/L 170		1.70	2.3			●	●	●
TGF32R/L 175		1.75	2.3			●	●	●
TGF32R/L 180		1.80	2.3			●	●	●

TGF__R/L

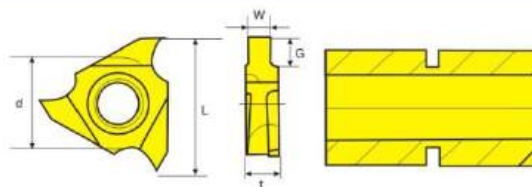
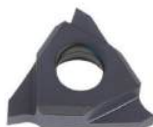

Модель	Размеры					Материал		
	L	W	G	d	t	LF6018	LF6118	LDA
TGF32R/L 190	16	1.90	2.8	3/8	3.18	●	●	●
TGF32R/L 195		1.95	2.8			●	●	●
TGF32R/L 200		2.00	2.8			●	●	●
TGF32R/L 210		2.10	2.8			●	●	●
TGF32R/L 215		2.15	2.8			●	●	●
TGF32R/L 220		2.20	2.8			●	●	●
TGF32R/L 225		2.25	2.8			●	●	●
TGF32R/L 230		2.30	2.8			●	●	●
TGF32R/L 240		2.40	2.8			●	●	●
TGF32R/L 245		2.45	2.8			●	●	●
TGF32R/L 250		2.50	2.8			●	●	●
TGF32R/L 260		2.60	2.8			●	●	●
TGF32R/L 270		2.70	2.8			●	●	●
TGF32R/L 275		2.75	2.8			●	●	●
TGF32R/L 280		2.80	2.8			●	●	●
TGF32R/L 290		2.90	2.8			●	●	●
TGF32R/L 300	3.00	2.8	●	●	●			

ER(IR)/IL(EL)

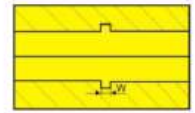
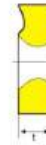
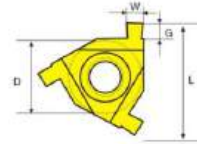

Модель	Размеры					Материал		
	L	W	G	d	t	LF6018	LF6118	LDA
ER/IL (IR/EL) 0.75	08	0.75	0.8	3/16	2.2	●	●	●
ER/IL (IR/EL) 0.80		0.80	0.8			●	●	●
ER/IL (IR/EL) 0.85		0.85	0.8			●	●	●
ER/IL (IR/EL) 0.90		0.90	0.8			●	●	●
ER/IL (IR/EL) 1.00		1.00	0.8			●	●	●
ER/IL (IR/EL) 0.80	11	0.80	0.8	1/4	3.2	●	●	●
ER/IL (IR/EL) 0.85		0.85	0.8			●	●	●
ER/IL (IR/EL) 0.90		0.90	0.8			●	●	●
ER/IL (IR/EL) 1.00		1.00	0.8			●	●	●
ER/IL (IR/EL) 1.10		1.10	0.8			●	●	●
ER/IL (IR/EL) 1.20		1.20	0.8			●	●	●
ER/IL (IR/EL) 1.25		1.25	0.8			●	●	●
ER/IL (IR/EL) 1.30		1.30	0.8			●	●	●
ER/IL (IR/EL) 1.40		1.40	0.8			●	●	●
ER/IL (IR/EL) 1.50		1.50	0.8			●	●	●
ER/IL (IR/EL) 2.00	2.00	0.8	●	●	●			
ER/IL (IR/EL) 0.80	16	0.80	0.8	3/8	3.65	●	●	●
ER/IL (IR/EL) 0.90		0.90	0.8			●	●	●
ER/IL (IR/EL) 1.00		1.00	0.8			●	●	●
ER/IL (IR/EL) 1.05		1.05	0.8			●	●	●
ER/IL (IR/EL) 1.10		1.10	0.8			●	●	●

ER(IR)/IL(EL)

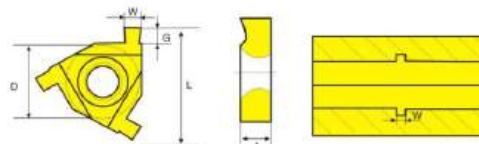

Модель	Размеры					Материал		
	L	W	G	d	t	LF6018	LF6118	LDA
ER/IL (IR/EL) 1.20	16	1.20	0.8	3/8	3.65	●	●	●
ER/IL (IR/EL) 1.25		1.25	0.8			●	●	●
ER/IL (IR/EL) 1.30		1.30	0.8			●	●	●
ER/IL (IR/EL) 1.35		1.35	0.8			●	●	●
ER/IL (IR/EL) 1.40		1.40	0.8			●	●	●
ER/IL (IR/EL) 1.45		1.45	0.8			●	●	●
ER/IL (IR/EL) 1.50		1.50	0.8			●	●	●
ER/IL (IR/EL) 1.55		1.55	0.8			●	●	●
ER/IL (IR/EL) 1.60		1.60	0.8			●	●	●
ER/IL (IR/EL) 1.65		1.65	0.8			●	●	●
ER/IL (IR/EL) 1.70		1.70	0.8			●	●	●
ER/IL (IR/EL) 1.75		1.75	0.8			●	●	●
ER/IL (IR/EL) 1.80		1.80	0.8			●	●	●
ER/IL (IR/EL) 1.85		1.85	0.8			●	●	●
ER/IL (IR/EL) 1.90		1.90	0.8			●	●	●
ER/IL (IR/EL) 2.00		2.00	0.8			●	●	●
ER/IL (IR/EL) 2.05		2.05	0.8			●	●	●
ER/IL (IR/EL) 2.10		2.10	0.8			●	●	●
ER/IL (IR/EL) 2.15		2.15	0.8			●	●	●
ER/IL (IR/EL) 2.20		2.20	0.8			●	●	●
ER/IL (IR/EL) 2.25		2.25	0.8			●	●	●
ER/IL (IR/EL) 2.30	2.30	0.8	●	●	●			
ER/IL (IR/EL) 2.40	2.40	0.8	●	●	●			
ER/IL (IR/EL) 2.50	2.50	0.8	●	●	●			
ER/IL (IR/EL) 2.55	2.55	0.8	●	●	●			
ER/IL (IR/EL) 2.60	2.60	0.8	●	●	●			
ER/IL (IR/EL) 2.70	2.70	0.8	●	●	●			
ER/IL (IR/EL) 2.80	2.80	0.8	●	●	●			
ER/IL (IR/EL) 2.90	2.90	0.8	●	●	●			
ER/IL (IR/EL) 3.00	3.00	0.8	●	●	●			

Резьбовые пластины

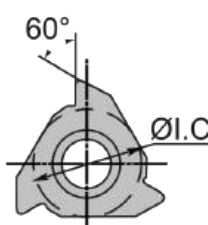
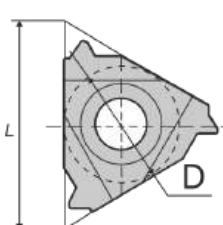
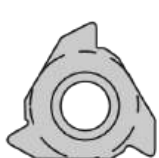
16		E	R	1.5	ISO		
1 размер пластины		2 тип пластины		4 шаг резьбы			
L, мм	D	E - наружная		Полный профиль			
8	3/16"			мм	TPI		
11	1/4"			0,5~0,6	48~4		
16	3/8"			Неполный профиль			
22	1/2"			код	мм	TPI	
27	5/8"			A	0,5~1,5	48~16	
		I - внутренняя		AG	0,5~3,0	48~8	
				G	1,75~3	14~8	
				N	3,5~5,0	7~5	
				Q	5,5~6,0	4,5~4	
				6 сплавы		Трубная резьба международный стандарт NPT 60°	
LDA	Нержавеющая сталь, углеродистая сталь				Трубная резьба британский стандарт BSPT 55°		
LDC	Углеродистые и легированные стали, алюминиевые и медные сплавы				Американский ACME 29°		
LF6018	Нержавеющая сталь, легированная сталь, жаропрочная сталь на низких скоростях резания. подходит для штампованной углеродистой стали с твердостью равной или ниже HRC40				Трапецидальная резьба TR-30°		
LF6028	Нержавеющая сталь. подходит для углеродистой стали с твердостью равной или ниже HRC30				Американский BUTTRESS (ABUT)		
LF6118	Для всех типов сталей и чугуна. Оптимален для нержавеющей стали				Круглая резьба (RD)		
LF9018	Углеродистая и легированная сталь						
K10	Неметаллические материалы, алюминиевые и медные сплавы						

Универсальное применение

УНИВЕРСАЛЬНЫЙ ПРОФИЛЬ 60°

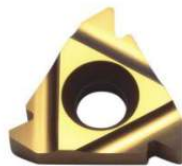
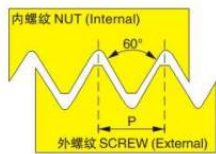
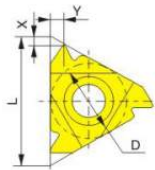

	D	Размеры		Обозначение		Размеры		
		мм	TPI	правой СМП	левой СМП	L	X	Y
Наружная	1/4"	0.5 ~ 1.5	48 ~ 16	11ER A60	11EL A60	11	0.8	0.9
		0.5 ~ 1.5	48 ~ 16	16ER A60	16EL A60			
	3/8"	0.5 ~ 3.0	48 ~ 8	16ER AG60	16EL AG60	16	1.2	1.7
		1.75 ~ 3.0	14 ~ 8	16ER G60	16EL G60			
	1/2"	3.5 ~ 5.0	7 ~ 5	22ER N60	22EL N60	22	1.7	2.5
5/8"	5.5 ~ 6.0	4.5 ~ 4	27ER Q60	27EL Q60	27	2.1	3.1	
Внутренняя	1/4"	0.5 ~ 1.5	48 ~ 16	11IR A60	11IL A60	11	0.8	0.9
		0.5 ~ 1.5	48 ~ 16	16IR A60	16IL A60			
	3/8"	0.5 ~ 3.0	48 ~ 8	16IR AG60	16IL AG60	16	1.2	1.7
		1.75 ~ 3.0	14 ~ 8	16IR G60	16IL G60			
	1/2"	3.5 ~ 5.0	7 ~ 5	22IR N60	22IL N60	22	1.7	2.5
5/8"	5.5 ~ 6.0	4.5 ~ 4	27IR Q60	27IL Q60	27	1.8	2.7	

Универсальное применение

УНИВЕРСАЛЬНЫЙ ПРОФИЛЬ 55°

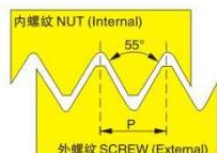
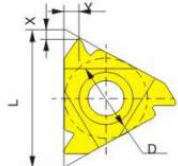

	D	Размеры		Обозначение		Размеры		
		мм	TPI	правой СМП	левой СМП	L	X	Y
Наружная	1/4"	0.5 ~ 1.5	48 ~ 16	11ER A55	11EL A55	11	0.8	0.9
		0.5 ~ 1.5	48 ~ 16	16ER A55	16EL A55			
	3/8"	0.5 ~ 3.0	48 ~ 8	16ER AG55	16EL AG55	16	1.2	1.7
		1.75 ~ 3.0	14 ~ 8	16ER G55	16EL G55			
	1/2"	3.5 ~ 5.0	7 ~ 5	22ER N55	22EL N55	22	1.7	2.5
5/8"	5.5 ~ 6.0	4.5 ~ 4	27ER Q55	27EL Q55	27	2.0	2.9	
Внутренняя	1/4"	0.5 ~ 1.5	48 ~ 16	11IR A55	11IL A55	11	0.8	0.9
		0.5 ~ 1.5	48 ~ 16	16IR A55	16IL A55			
	3/8"	0.5 ~ 3.0	48 ~ 8	16IR AG55	16IL AG60	16	1.2	1.7
		1.75 ~ 3.0	14 ~ 8	16IR G55	16IL G55			
	1/2"	3.5 ~ 5.0	7 ~ 5	22IR N55	22IL N55	22	1.7	2.5
5/8"	5.5 ~ 6.0	4.5 ~ 4	27IR Q55	27IL Q55	27	2.0	2.9	

Универсальное применение

УНИВЕРСАЛЬНЫЙ ПРОФИЛЬ 60°

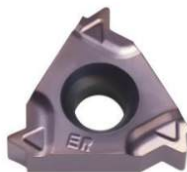
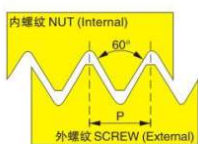
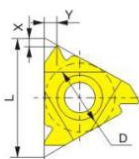

	D	Размеры		Обозначение		Размеры		
		мм	TPI	правой СМП	левой СМП	L	X	Y
Наружная	3/8"	0.5 ~ 1.5	48 ~ 16	16ER A60	16EL A60	16	0.8	0.9
		0.5 ~ 3.0	48 ~ 8	16ER AG60	16EL AG60			
		1.75 ~ 3.0	14 ~ 8	16ER G60	16EL G60			
Внутренняя	3/8"	0.5 ~ 1.5	48 ~ 16	16IR A60	16IL A60	16	0.8	0.9
		0.5 ~ 3.0	48 ~ 8	16IR AG60	16IL AG60			
		1.75 ~ 3.0	14 ~ 8	16IR G60	16IL G60			

Универсальное применение

УНИВЕРСАЛЬНЫЙ ПРОФИЛЬ 55°

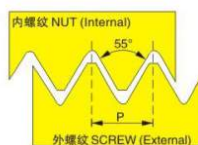
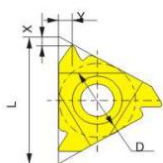

	D	Размеры		Обозначение		Размеры		
		мм	TPI	правой СМП	левой СМП	L	X	Y
Наружная	3/8"	0.5 ~ 1.5	48 ~ 16	16ER A55	16EL A55	16	0.8	0.9
		0.5 ~ 3.0	48 ~ 8	16ER AG55	16EL AG55			
		1.75 ~ 3.0	14 ~ 8	16ER G55	16EL G55			
Внутренняя	3/8"	0.5 ~ 1.5	48 ~ 16	16IR A55	16IL A55	16	0.8	0.9
		0.5 ~ 3.0	48 ~ 8	16IR AG55	16IL AG55			
		1.75 ~ 3.0	14 ~ 8	16IR G55	16IL G55			

МЕТРИЧЕСКИЙ ПРОФИЛЬ ISO

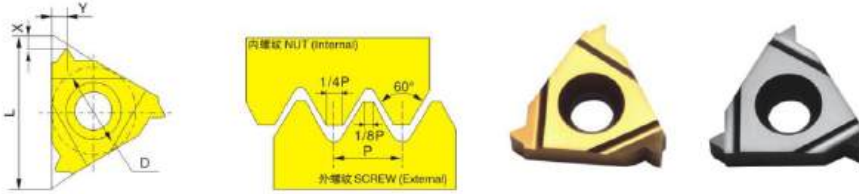

	D	Шаг	Обозначение		Размеры			
		мм	правой СМП	левой СМП	L	X	Y	
Наружная	1/4"	0.50	11ER0.50 ISO	11EL0.50 ISO	11	0.6	0.6	
		0.75	11ER0.75 ISO	11EL0.75 ISO		0.6	0.6	
		1.00	11ER1.00 ISO	11EL1.00 ISO		0.7	0.7	
		1.25	11ER1.25 ISO	11EL1.25 ISO		0.8	0.9	
		1.50	11ER1.50 ISO	11EL1.50 ISO		0.8	1.0	
		1.75	11ER1.75 ISO	11EL1.75 ISO		0.8	1.1	
	3/8"	0.50	16ER0.50 ISO	16EL0.50 ISO	16	0.6	0.6	
		0.75	16ER0.75 ISO	16EL0.75 ISO		0.6	0.7	
		1.00	16ER1.00 ISO	16EL1.00 ISO		0.7	0.8	
		1.25	16ER1.25 ISO	16EL1.25 ISO		0.8	0.9	
		1.50	16ER1.50 ISO	16EL1.50 ISO		0.8	1.0	
		1.75	16ER1.75 ISO	16EL1.75 ISO		0.9	1.2	
		2.00	16ER2.00 ISO	16EL2.00 ISO		1.0	1.3	
		2.50	16ER2.50 ISO	16EL2.50 ISO		1.1	1.5	
	1/2"	3.00	16ER3.00 ISO	16EL3.00 ISO	22	1.2	1.6	
		3.50	22ER3.50 ISO	22EL3.50 ISO		1.6	2.3	
		4.00	22ER4.00 ISO	22EL4.00 ISO		1.6	2.3	
		4.50	22ER4.50 ISO	22EL4.50 ISO		1.7	2.4	
			5.00	22ER5.00 ISO	22EL5.00 ISO		1.7	2.5

МЕТРИЧЕСКИЙ ПРОФИЛЬ ISO

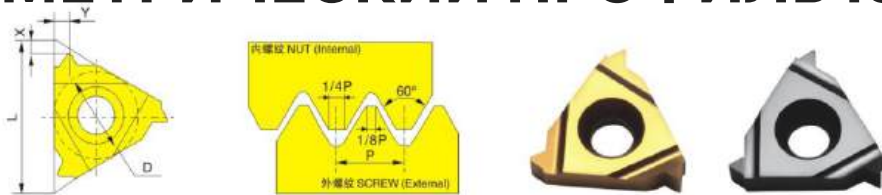

	D	Шаг	Обозначение		Размеры		
		мм	правой СМП	левой СМП	L	X	Y
Внутренняя	1/4"	0.50	11IR0.50 ISO	11IL0.50 ISO	11	0.6	0.6
		0.75	11IR0.75 ISO	11IL0.75ISO		0.6	0.6
		1.00	11IR1.00 ISO	11IL1.00 ISO		0.6	0.7
		1.25	11IR1.25 ISO	11IL1.25 ISO		0.8	0.9
		1.50	11IR1.50 ISO	11IL1.50 ISO		0.8	1.0
		1.75	11IR1.75 ISO	11IL1.75 ISO		0.9	1.1
		2.00	11IR2.00 ISO	11IL2.00 ISO		1.0	1.3
	3/8"	0.50	16IR0.50 ISO	16IL0.50 ISO	16	0.6	0.6
		0.75	16IR0.75 ISO	16IL0.75 ISO		0.6	0.6
		1.00	16IR1.00 ISO	16IL1.00 ISO		0.6	0.7
		1.25	16IR1.25 ISO	16IL1.25 ISO		0.8	0.9
		1.50	16IR1.50 ISO	16IL1.50 ISO		0.8	1.0
		1.75	16IR1.75 ISO	16IL1.75 ISO		0.9	1.2
		2.00	16IR2.00 ISO	16IL2.00 ISO		1.0	1.3
		2.50	16IR2.50 ISO	16IL2.50 ISO		1.1	1.5
		3.00	16IR3.00 ISO	16IL3.00 ISO		1.1	1.5
	1/2"	3.50	22IR3.50 ISO	22IL3.50 ISO	22	1.6	2.3
		4.00	22IR4.00 ISO	22IL4.00 ISO		1.6	2.3
		4.50	22IR4.50 ISO	22IL4.50 ISO		1.6	2.4
		5.00	22IR5.00 ISO	22IL5.00 ISO		1.6	2.5

МЕТРИЧЕСКИЙ ПРОФИЛЬ ISO

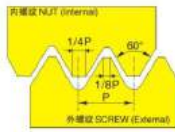
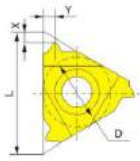

	D	Шаг	Обозначение		Размеры		
		мм	правой СМП	левой СМП	L	X	Y
Наружная	3/8"	0.50	16ER0.50 ISO	16EL0.50 ISO	16	0.6	0.6
		0.75	16ER0.75 ISO	16EL0.75 ISO		0.6	0.7
		1.00	16ER1.00 ISO	16EL1.00 ISO		0.7	0.8
		1.25	16ER1.25 ISO	16EL1.25 ISO		0.8	0.9
		1.50	16ER1.50 ISO	16EL1.50 ISO		0.8	1.0
		1.75	16ER1.75 ISO	16EL1.75 ISO		0.9	1.2
		2.00	16ER2.00 ISO	16EL2.00 ISO		1.0	1.3
		2.50	16ER2.50 ISO	16EL2.50 ISO		1.1	1.5
		3.00	16ER3.00 ISO	16EL3.00 ISO		1.2	1.6
Внутренняя	3/8"	0.50	16IR0.50 ISO	16IL0.50 ISO	16	0.6	0.6
		0.75	16IR0.75 ISO	16IL0.75 ISO		0.6	0.6
		1.00	16IR1.00 ISO	16IL1.00 ISO		0.6	0.7
		1.25	16IR1.25 ISO	16IL1.25 ISO		0.8	0.9
		1.50	16IR1.50 ISO	16IL1.50 ISO		0.8	1.0
		1.75	16IR1.75 ISO	16IL1.75 ISO		0.9	1.2
		2.00	16IR2.00 ISO	16IL2.00 ISO		1.0	1.3
		2.50	16IR2.50 ISO	16IL2.50 ISO		1.1	1.5
		3.00	16IR3.00 ISO	16IL3.00 ISO		1.1	1.5

Американский профиль 60°

АМЕРИКАНСКИЙ ПРОФИЛЬ 60°

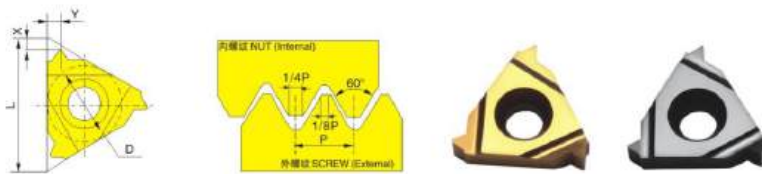

	D	Шаг	Обозначение		Размеры		
		TPI	правой СМП	левой СМП	L	X	Y
Наружная	1/4"	32	11ER32 UN	11EL32 UN	11	0.6	0.6
		28	11ER28 UN	11EL28 UN		0.6	0.7
		24	11ER24 UN	11EL24 UN		0.7	0.8
		20	11ER20 UN	11EL20 UN		0.8	0.9
		18	11ER18 UN	11EL18 UN		0.8	1.0
		16	11ER16 UN	11EL16 UN		0.9	1.1
	3/8"	32	16ER32 UN	16EL32 UN	16	0.6	0.6
		28	16ER28 UN	16EL28 UN		0.6	0.7
		24	16ER24 UN	16EL24 UN		0.7	0.8
		20	16ER20 UN	16EL20 UN		0.8	0.9
		18	16ER18 UN	16EL18 UN		0.8	1.0
		16	16ER16 UN	16EL16 UN		0.9	1.1
		14	16ER14 UN	16EL14 UN		1.0	1.2
		13	16ER13 UN	16EL13 UN		1.1	1.3
		12	16ER12 UN	16EL12 UN		1.1	1.4
		11.5	16ER11.5 UN	16EL11.5 UN		1.1	1.4
		11	16ER11 UN	16EL11 UN		1.1	1.5
		10	16ER10 UN	16EL10 UN		1.1	1.5
		9	16ER9 UN	16EL9 UN		1.2	1.7
		8	16ER8 UN	16EL8 UN		1.2	2.0
1/2"	5	22ER5 UN	22EL5 UN	22	1.7	2.5	

АМЕРИКАНСКИЙ ПРОФИЛЬ 60°

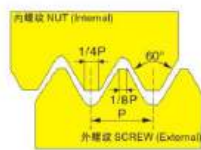
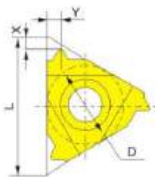

	D	Шаг	Обозначение		Размеры		
		TPI	правой СМП	левой СМП	L	X	Y
Внутренняя	1/4"	32	11IR32 UN	11IL32 UN	11	0.6	0.6
		28	11IR28 UN	11IL28 UN		0.6	0.7
		24	11IR24 UN	11IL24 UN		0.7	0.8
		20	11IR20 UN	11IL20 UN		0.8	0.9
		18	11IR18 UN	11IL18 UN		0.8	1.0
		16	11IR16 UN	11IL16 UN		0.9	1.1
	3/8"	32	16IR32 UN	16IL32 UN	16	0.6	0.6
		28	16IR28 UN	16IL28 UN		0.6	0.7
		24	16IR24 UN	16IL24 UN		0.7	0.8
		20	16IR20 UN	16IL20 UN		0.8	0.9
		18	16IR18 UN	16IL18 UN		0.8	1.0
		16	16IR16 UN	16IL16 UN		0.9	1.1
		14	16IR14 UN	16IL14 UN		1.0	1.2
		13	16IR13 UN	16IL13 UN		1.0	1.3
		12	16IR12 UN	16IL12 UN		1.1	1.4
		11	16IR11 UN	16IL11 UN		1.1	1.5
		10	16IR10 UN	16IL10 UN		1.1	1.5
		9	16IR9 UN	16IL9 UN		1.2	1.7
	8	16IR8 UN	16IL8 UN	1.2	2.0		
	1/2"	7	22IR7 UN	22IL7 UN	22	1.6	2.3
		5	22IR5 UN	22IL5 UN		1.7	2.5
	5/8"	4.5	27IR4.5 UN	27IL4.5 UN	27	1.9	2.7

Для авиационной и аэрокосмической промышленности

ДЮЙМОВАЯ РЕЗЬБА UNJ 60°

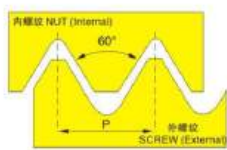
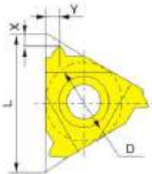

	D	Шаг	Обозначение		Размеры		
		TPI	правой СМП	левой СМП	L	X	Y
Наружная	1/4"	28	11ER28 UNJ	11EL28 UNJ	11	0.7	0.7
		24	11ER24 UNJ	11EL24 UNJ		0.7	0.8
		16	11ER16 UNJ	11EL16 UNJ		0.9	1.1
		14	11ER14 UNJ	11EL14 UNJ		1.0	1.2
	3/8"	28	16ER28 UNJ	16EL28 UNJ	16	0.7	0.7
		18	16ER18 UNJ	16EL18 UNJ		0.8	1.0
		16	16ER16 UNJ	16EL16 UNJ		0.9	1.1
		14	16ER14 UNJ	16EL14 UNJ		1.0	1.2
		13	16ER13 UNJ	16EL13 UNJ		1.0	1.3
		10	16ER10 UNJ	16EL10 UNJ		1.2	1.5
		8	16ER8 UNJ	16EL8 UNJ		1.2	1.6
	1/2"	7	22ER7 UNJ	22EL7 UNJ	22	1.7	2.3
		5	22ER5 UNJ	22EL5 UNJ		1.8	2.5
	5/8"	4	27ER4 UNJ	27EL4 UNJ	27	2.2	3.0

ДЮЙМОВАЯ РЕЗЬБА UNJ 60°

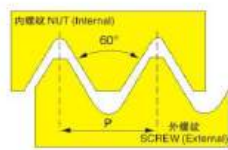
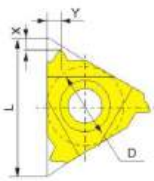

	D	Шаг	Обозначение		Размеры		
		TPI	правой СМП	левой СМП	L	X	Y
Внутренняя	1/4"	28	11IR28 UNJ	11IL28 UNJ	11	0.7	0.7
		24	11IR24 UNJ	11IL24 UNJ		0.7	0.8
		20	11IR20 UNJ	11IL20 UNJ		0.8	0.9
		18	11IR18 UNJ	11IL18 UNJ		0.8	1.0
		16	11IR16 UNJ	11IL16 UNJ		0.9	1.1
		14	11IR14 UNJ	11IL14 UNJ		1.0	1.2
	3/8"	28	16IR28 UNJ	16IL28 UNJ	16	0.7	0.7
		24	16IR24 UNJ	16IL24 UNJ		0.7	0.8
		20	16IR20 UNJ	16IL20 UNJ		0.8	0.9
		18	16IR18 UNJ	16IL18 UNJ		0.8	1.0
		16	16IR16 UNJ	16IL16 UNJ		0.9	1.1
		14	16IR14 UNJ	16IL14 UNJ		1.0	1.2
		13	16IR13 UNJ	16IL13 UNJ		1.0	1.3
		12	16IR12 UNJ	16IL12 UNJ		1.1	1.3
		11	16IR11 UNJ	16IL11 UNJ		1.2	1.5
		10	16IR10 UNJ	16IL10 UNJ		1.2	1.5
	1/2"	7	22IR7 UNJ	22IL7 UNJ	22	1.7	2.3
		6	22IR6 UNJ	22IL6 UNJ		1.6	2.3
		5	22IR5 UNJ	22IL5 UNJ		1.8	2.5
	5/8"	4.5	27IR4.5 UNJ	27IL4.5 UNJ	27	2.0	2.7
		4	27IR4 UNJ	27IL4 UNJ		2.2	3.0

Для подключения газовых, водородных кранов и труб

БРИТАНСКИЙ ПРОФИЛЬ WHITWORTH 55°

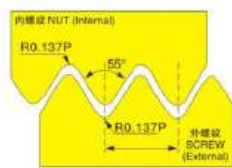
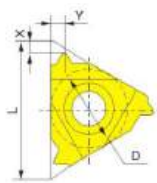

	D	Шаг	Обозначение		Размеры		
		TPI	правой СМП	левой СМП	L	X	Y
Наружная	1/4"	28	11ER28 W	11EL28 W	11	0.6	0.7
		26	11ER26 W	11EL26 W		0.7	0.8
		20	11ER20 W	11EL20 W		0.8	0.9
		19	11ER19 W	11EL19 W		0.8	1.0
		18	11ER18 W	11EL18 W		0.8	1.0
		16	11ER16 W	11EL16 W		0.9	1.1
		14	16ER14 W	16EL14 W		1.0	1.2
	3/8"	28	16ER28 W	16EL28 W	16	0.6	0.7
		26	16ER26 W	16EL26 W		0.7	0.8
		20	16ER20 W	16EL20 W		0.8	0.9
		19	16ER19 W	16EL19 W		0.8	1.0
		18	16ER18 W	16EL18 W		0.8	0.9
		16	16ER16 W	16EL16 W		0.9	1.1
		14	16ER14 W	16EL14 W		1.0	1.2
		12	16ER12 W	16EL12 W		1.1	1.4
		11	16ER11 W	16EL11 W		1.1	1.5
		10	16ER10 W	16EL10 W		1.1	1.5
		9	16ER8 W	16EL9 W		1.2	1.5
	1/2"	8	16ER8 W	16EL8 W	1.2	1.7	
		7	22ER7 W	22EL7 W	22	1.6	2.3
		6	22ER6 W	22EL6 W		1.6	2.3
	5	22ER5 W	22EL5 W	1.7		2.4	
	5/8"	4.5	27ER4.5 W	27EL4.5 W	27	1.8	2.6
		4	27ER4 W	27EL4 W		2.0	2.9

Для подключения газовых, водородных кранов и труб

БРИТАНСКИЙ ПРОФИЛЬ WHITWORTH 55°

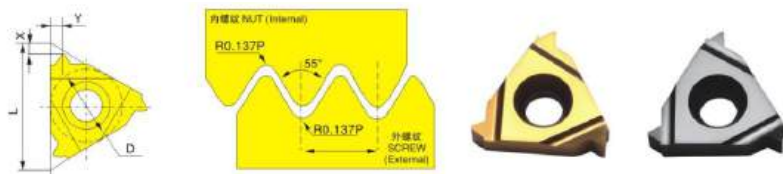

	D	Шаг	Обозначение		Размеры		
		TPI	правой СМП	левой СМП	L	X	Y
Внутренняя	1/4"	28	11IR28 W	11IL28 W	11	0.6	0.6
		26	11IR26 W	11IL26 W		0.6	0.7
		20	11IR20 W	11IL20 W		0.7	0.9
		19	11IR19 W	11IL19 W		0.8	1.0
		18	11IR18 W	11IL18 W		0.8	1.0
		16	11IR16 W	11IL16 W		0.9	1.1
		14	11IR14 W	11IL14 W		1.0	1.2
	3/8"	28	16IR28 W	16IL28 W	16	0.6	0.7
		26	16IR26 W	16IL26 W		0.7	0.8
		20	16IR20 W	16IL20 W		0.8	0.9
		19	16IR19 W	16IL19 W		0.8	1.0
		18	16IR18 W	16IL18 W		0.8	1.0
		16	16IR16 W	16IL16 W		0.9	1.1
		14	16IR14 W	16IL14 W		1.0	1.2
		12	16IR12 W	16IL12 W		1.1	1.4
		11	16IR11 W	16IL11 W		1.1	1.5
		10	16IR10 W	16IL10 W		1.1	1.5
		9	16IR9 W	16IL9 W		1.2	1.5
	1/2"	7	22IR7 W	22IL7 W	22	1.6	2.3
		6	22IR6 W	22IL6 W		1.6	2.3
		5	22IR5 W	22IL5 W		1.7	2.4
	5/8"	4.5	27IR4.5 W	27IL4.5 W	27	1.8	2.6
		4	27IR4 W	27IL4 W		2.0	2.9

Для подключения газовых, водородных кранов и труб

БРИТАНСКИЙ ПРОФИЛЬ WHITWORTH 55°

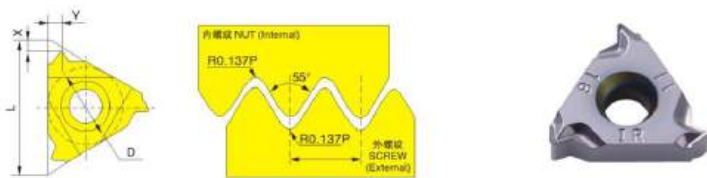

	D	Шаг	Обозначение		Размеры		
		TPI	правой СМП	левой СМП	L	X	Y
Наружная	3/8"	28	16ER28 W	16EL28 W	16	0.6	0.7
		26	16ER26 W	16EL26 W		0.7	0.8
		20	16ER20 W	16EL20 W		0.8	0.9
		19	16ER19 W	16EL19 W		0.8	1.0
		18	16ER18 W	16EL18 W		0.8	0.9
		16	16ER16 W	16EL16 W		0.9	1.1
		14	16ER14 W	16EL14 W		1.0	1.2
		12	16ER12 W	16EL12 W		1.1	1.4
		11	16ER11 W	16EL11 W		1.1	1.5
		10	16ER10 W	16EL10 W		1.1	1.5
		9	16ER8 W	16EL9 W		1.2	1.5
		8	16ER8 W	16EL8 W		1.2	1.7
Внутренняя	3/8"	28	16IR28 W	16IL28 W	16	0.6	0.7
		26	16IR26 W	16IL26 W		0.7	0.8
		20	16IR20 W	16IL20 W		0.8	0.9
		19	16IR19 W	16IL19 W		0.8	1.0
		18	16IR18 W	16IL18 W		0.8	1.0
		16	16IR16 W	16IL16 W		0.9	1.1
		14	16IR14 W	16IL14 W		1.0	1.2
		12	16IR12 W	16IL12 W		1.1	1.4
		11	16IR11 W	16IL11 W		1.1	1.5
		10	16IR10 W	16IL10 W		1.1	1.5
		9	16IR8 W	16IL9 W		1.2	1.5
		8	16IR8 W	16IL8 W		1.2	1.7

АМЕРИКАНСКАЯ ТРУБНАЯ РЕЗЬБА 60°

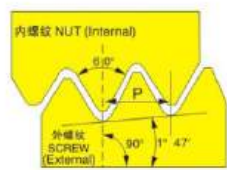
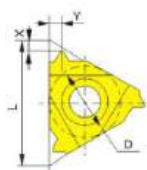

	D	Шаг	Обозначение		Размеры			
		ТPI	правой СМП	левой СМП	L	X	Y	
Наружная	1/4"	27	11ER27 W	11EL27 W	11	0.7	0.8	
		18	11ER18 W	11EL18 W		0.8	1.0	
		14	11ER14 W	11EL14 W		0.8	1.0	
	3/8"	27	16ER27 W	16EL27 W	16	0.7	0.8	
		18	16ER18 W	16EL18 W		0.8	1.0	
		14	16ER14 W	16EL14 W		0.9	1.2	
		11.5	16ER11.5 W	16EL11.5W		1.1	1.5	
		8	16ER8 W	16EL8 W		1.2	1.8	
	Внутренняя	1/4"	27	11IR27 W	11IL27 W	11	0.7	0.8
			18	11IR18 W	11IL18 W		0.8	1.0
14			11IR14 W	11IL14 W	0.8		1.0	
3/8"		27	16IR27 W	16IL27 W	16	0.7	0.8	
		18	16IR18 W	16IL18 W		0.8	1.0	
		14	16IR14 W	16IL14 W		0.9	1.2	
		11.5	16IR11.5 W	16IL11.5W		1.1	1.5	
		8	16IR8 W	16IL8 W		1.2	1.8	

NPTF 60°

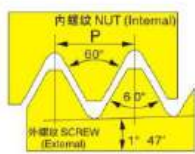
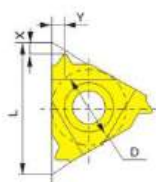

	D	Шаг	Обозначение		Размеры			
		ТPI	правой СМП	левой СМП	L	X	Y	
Наружная	1/4"	27	11ER27 NPTF	11EL27 NPTF	11	0.7	0.8	
		18	11ER18 NPTF	11EL18 NPTF		0.8	1.0	
		14	11ER14 NPTF	11EL14 NPTF		0.8	1.0	
	3/8"	27	16ER27 NPTF	16EL27 NPTF	16	0.7	0.8	
		18	16ER18 NPTF	16EL18 NPTF		0.8	1.0	
		14	16ER14 NPTF	16EL14 NPTF		0.9	1.2	
		11.5	16ER11.5 NPTF	16EL11.5 NPTFW		1.1	1.5	
		8	16ER8 NPTF	16EL8 NPTF		1.2	1.8	
	Внутренняя	1/4"	27	11IR27 NPTF	11IL27 NPTF	11	0.7	0.8
			18	11IR18 NPTF	11IL18 NPTF		0.8	1.0
14			11IR14 NPTF	11IL14 NPTF	0.8		1.0	
3/8"		27	16IR27 NPTF	16IL27 NPTF	16	0.7	0.8	
		18	16IR18 NPTF	16IL18 NPTF		0.8	1.0	
		14	16IR14 NPTF	16IL14 NPTF		0.9	1.2	
		11.5	16IR11.5 NPTF	16IL11.5 NPTF		1.1	1.5	
		8	16IR8 NPTF	16IL8 NPTF		1.2	1.8	

Английская трубная резьба

BSPT 55°

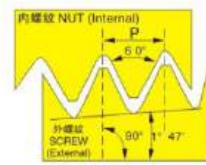
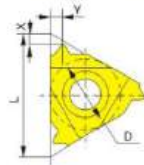

	D	Шаг	Обозначение		Размеры		
		ТPI	правой СМП	левой СМП	L	X	Y
Наружная	1/4"	28	11ER28 BSPT	11EL28 BSPT	11	0.6	0.6
		19	11ER19 BSPT	11EL19 BSPT		0.8	0.9
		14	11ER14 BSPT	11EL14 BSPT		0.9	1.0
	3/8"	28	16ER28 BSPT	16EL28 BSPT	16	0.6	0.6
		19	16ER19 BSPT	16EL19 BSPT		0.8	0.9
		14	16ER14 BSPT	16EL14 BSPT		1.0	1.2
11		16ER11 BSPT	16EL11 BSPT	1.1		1.5	
Внутренняя	1/4"	28	11IR28 BSPT	11IL29 BSPT	11	0.6	0.8
		19	11IR19 BSPT	11IL19 BSPT		0.8	0.9
		14	11IR14 BSPT	11IL14 BSPT		0.9	1.0
	3/8"	28	16IR28 BSPT	16IL28 BSPT	16	0.6	0.6
		19	16IR19 BSPT	16IL19 BSPT		0.8	0.9
		14	16IR14 BSPT	16IL14 BSPT		1.0	1.2
		11	16IR11 BSPT	16IL11 BSPT		1.1	1.5

Английская резьба для механического привода

ACME 29°

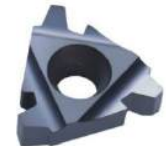
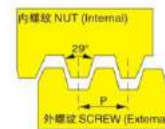
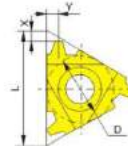

	D	Шаг	Обозначение		Размеры		
		ТPI	правой СМП	левой СМП	L	X	Y
Наружная	3/8"	16	16ER16 ACME	16EL16 ACME	16	1.0	0.1
		14	16ER14 ACME	16EL14 ACME		1.0	1.2
		12	16ER12 ACME	16EL12 ACME		1.1	1.2
		10	16ER10 ACME	16EL10 ACME		1.3	1.3
		8	16ER8 ACME	16EL8 ACME		1.4	1.5
	1/2"	6	22ER6 ACME	22EL6 ACME	22	1.8	2.1
		5	22ER5 ACME	22EL5 ACME	2.0	2.3	
Внутренняя	3/8"	14	16IR14 ACME	16IL14 ACME	16	1.0	1.2
		12	16IR12 ACME	16IL12 ACME		1.1	1.2
		10	16IR10 ACME	16IL10 ACME		1.3	1.3
		8	16IR8 ACME	16IL8 ACME		1.4	1.5
	1/2"	6	22IR6 ACME	22IL6 ACME	22	1.8	2.1
		5	22IR5 ACME	22IL5 ACME	2.0	2.3	

ТРАПЕЦИЕДАЛЬНАЯ 30°

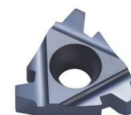
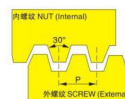
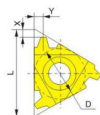

	D	Шаг	Обозначение		Размеры		
		мм	правой СМП	левой СМП	L	X	Y
Наружная	3/8"	1.5	16ER1.5 TR	16EL1.5 TR	16	1.0	1.1
		2.0	16ER2.0 TR	16EL2.0 TR		1.1	1.3
		3.0	16ER3.0 TR	16EL3.0 TR		1.3	1.5
	1/2"	4.0	22ER4.0 TR	16EL4.0 TR	22	1.7	1.9
		5.0	22ER5.0 TR	16EL5.0 TR		2.1	2.5
Внутренняя	3/8"	2.0	16IR2.0 TR	16IL2.0 TR	16	1.1	1.3
		3.0	16IR3.0 TR	16IL3.0 TR		1.3	1.5
	1/2"	4.0	22IR4.0 TR	16IL4.0 TR	22	1.7	1.9
		5.0	22IR5.0 TR	16IL5.0 TR		2.1	2.5

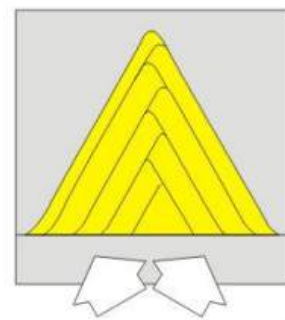
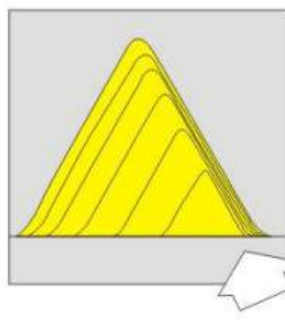
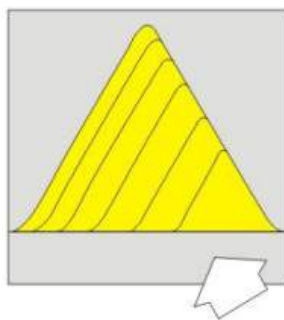
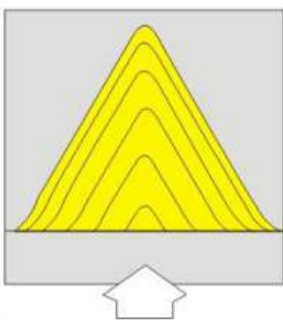

BUTTRESS 30°

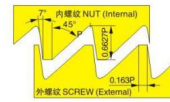
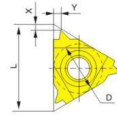

	D	Шаг	Обозначение		Размеры		
		ТPI	правой СМП	левой СМП	L	X	Y
Наружная	1/4"	20	11ER20 ABUT	11EL20 ABUT	11	1.0	1.4
		16	11ER16 ABUT	11EL16 ABUT		1.3	1.9
	3/8"	20	16ER20 ABUT	16EL20 ABUT	16	1.0	1.4
		16	16ER16 ABUT	16EL16 ABUT		1.3	1.9
		12	16ER12 ABUT	16EL12 ABUT		1.4	2.0
Внутренняя	1/2"	10	16ER10 ABUT	16EL10 ABUT	22	1.5	2.3
		8	22ER8 ABUT	22EL8 ABUT		2.0	3.2
	6	22ER6 ABUT	22EL6 ABUT	2.2	3.5		
	1/4"	20	11IR20 ABUT	11IL20 ABUT	11	1.0	1.4
		16	11IR16 ABUT	11IL16 ABUT		1.3	1.9
	3/8"	20	16IR20 ABUT	16IL20 ABUT	16	1.0	1.4
		16	16IR16 ABUT	16IL16 ABUT		1.3	1.9
		12	16IR12 ABUT	16IL12 ABUT		1.4	2.0
		10	16IR10 ABUT	16IL10 ABUT		1.5	2.3
	1/2"	8	22IR8 ABUT	22IL8 ABUT	22	2.0	3.2
		6	22IR6 ABUT	22IL6 ABUT		2.2	3.5



Пластины для обработки цветных металлов и сплавов

СТРУЖКОЛОМ СЕРИИ AL

Специальная геометрия пластины обеспечивает стабильное стружкодробление, уменьшение силы резания и увеличение стойкости СМП

Большое значение переднего угла уменьшает вероятность наростообразования

Низкая шероховатость передней поверхности снижает силу трения стружки и уменьшает нагревание СМП

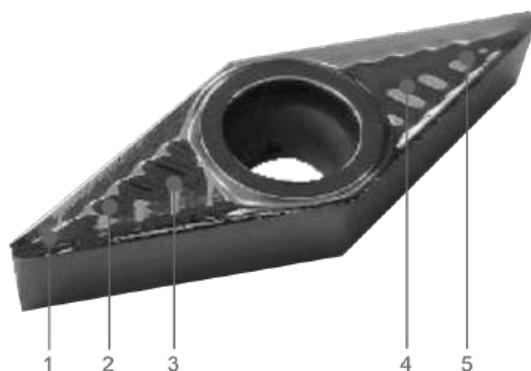

1. Большой угол наклона режущей кромки. Уменьшает силы резания. Уменьшение вероятности наростообразования.
2. Специальная геометрия стружколома. Устойчивое стружкодробление. Уменьшение вибраций.
3. Трехступенчатая передняя поверхность. Устойчивое стружкодробление при различных глубинах резания.
4. Малый угол заострения (сверхположительная геометрия). Уменьшение силы резания. Уменьшение вероятности наростообразования.
5. Хорошая полировка передней поверхности. Уменьшает силы резания. Уменьшение вероятности наростообразования. Устойчивое стружкодробление.

РЕКОМЕНДОВАННАЯ ОБЛАСТЬ ПРИМЕНЕНИЯ

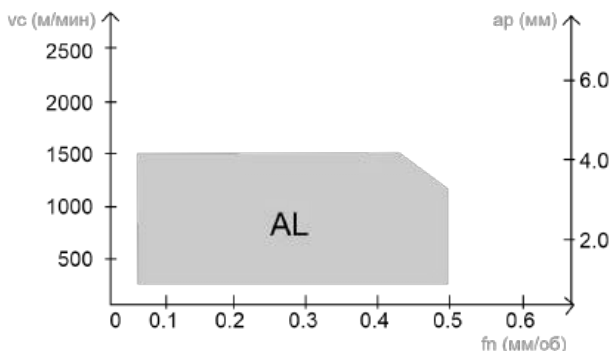

	Рекомендуемые режимы резания	Марка сплава
AL	$ap=0.1\sim0.5$ $fn=0.03\sim0.5\text{мм/об}$	K10(Твердый сплав K10-K20) ND 1000 (Алмазное покрытие) PD 1000 (DLC покрытие)

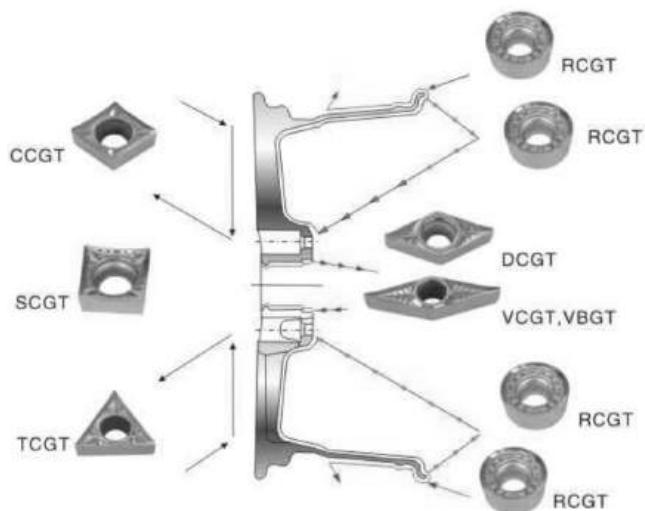

Точение колесного легкосплавного диска пластинами Deskar:

- CCGT
- DCGT
- SCGT
- TCGT
- RCGT
- VCGT, VBGT

ОБЩИЕ ХАРАКТЕРИСТИКИ СМП ИЗ СПЛАВА K10

1. Подходит для обработки алюминия и легированной стали - снижена вероятность наростообразования на режущей кромке
2. Трехмерная конструкция снижает усилия резания и обеспечивает высокую обрабатываемость при высокой подаче и скорости точения

ОБРАБАТЫВАЕМЫЙ МАТЕРИАЛ		ТВЕРДОСТЬ (НВ)	УДЕЛЬНАЯ СИЛА РЕЗАНИЯ (МПА)	VC (М/МИН)	FN (ММ/ОБ)
Алюминиевый сплав (штамповка)	до термообработки	50 ~ 70	500 ~ 600	1000 ~ 2500	0.1 ~ 0.6
	после термообработки	90 ~ 110	700 ~ 900	300 ~ 1000	0.1 ~ 0.5
Алюминиевый сплав (прокат)	до термообработки	70 ~ 80	700 ~ 800	300 ~ 1000	0.1 ~ 0.6
	после термообработки	80 ~ 100	800 ~ 950	200 ~ 600	0.1 ~ 0.4
Медные сплавы	-	90 ~ 110	700	250 ~ 600	0.1 ~ 0.5
Неметаллы	-	100	1700	150 ~ 300	0.1 ~ 0.6

Пластины для обработки цветных металлов и сплавов (положительная геометрия)

CC__80°

Ромб
Передний угол 7°

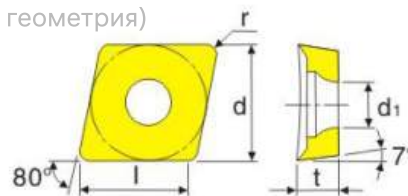

Обрабатываемый материал	Стали	P						Условия резания ● Непрерывное ⊕ Универсальное ⊗ Прерывистое
	Нержавеющие стали	M						
	Чугуны	K						
	Цветные металлы	N	⊕	⊕	●	⊕	⊗	
	Жаропрочные сплавы, титан	S						
	Материалы с повышенной твердостью	H						

Форма СМП	Модель	Без покрытия	Размеры (мм)					Условия резания	
		K10	l	d	t	r	d ₁	f _n (мм/об)	а _p (мм)
	060202-AL	●	6.2	6.35	2.38	0.2	2.8	0.01 - 0.12	0.05 - 3.00
	060204-AL	●	6.0	6.35	2.38	0.4	2.8	0.02 - 0.15	0.10 - 3.00
	060208-AL	●	5.6	6.35	2.38	0.8	2.8	0.02 - 0.20	0.10 - 4.00
	09Т302-AL	●	9.4	9.525	3.97	0.2	4.4	0.02 - 0.20	0.05 - 3.00
	09Т304-AL	●	9.2	9.525	3.97	0.4	4.4	0.02 - 0.30	0.10 - 5.00
	09Т308-AL	●	8.8	9.525	3.97	0.8	4.4	0.03 - 0.50	0.10 - 5.00
	120402-AL	●	12.6	12.7	4.76	0.2	5.5	0.02 - 0.30	0.05 - 4.00
	120404-AL	●	12.4	12.7	4.76	0.4	5.5	0.03 - 0.50	0.10 - 5.00
	120408-AL	●	12.0	12.7	4.76	0.8	5.5	0.04 - 0.80	0.10 - 5.50

Пластины для обработки цветных металлов и сплавов (положительная геометрия)

DC__55°

Ромб
Передний угол 7°

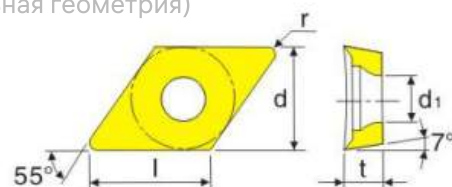

Обрабатываемый материал	Стали	P						Условия резания ● Непрерывное ⊕ Универсальное ⊗ Прерывистое
	Нержавеющие стали	M						
	Чугуны	K						
	Цветные металлы	N	⊕	⊕	●	⊕	⊗	
	Жаропрочные сплавы, титан	S						
	Материалы с повышенной твердостью	H						

Форма СМП	Модель	Без покрытия	Размеры (мм)					Условия резания	
		K10	l	d	t	r	d ₁	f _n (мм/об)	а _p (мм)
	070202-AL	●	7.5	6.35	2.38	0.2	2.8	0.01 - 0.20	0.05 - 3.00
	070204-AL	●	7.3	6.35	2.38	0.4	2.8	0.02 - 0.30	0.10 - 4.00
	070208-AL	●	6.8	6.35	2.38	0.8	2.8	0.03 - 0.40	0.10 - 4.00
	11Т302-AL	●	11.4	9.525	3.97	0.2	4.4	0.02 - 0.30	0.05 - 4.00
	11Т304-AL	●	11.2	9.525	3.97	0.4	4.4	0.03 - 0.50	0.10 - 5.00
	11Т308-AL	●	10.8	9.525	3.97	0.8	4.4	0.03 - 0.50	0.10 - 5.00
	11Т312-AL	●	10.4	9.525	3.97	1.2	4.4	0.04 - 0.60	0.15 - 5.00

Пластины для обработки цветных металлов и сплавов (положительная геометрия)

SC__90°

Ромб
Передний угол 7°

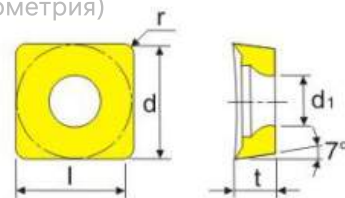

Обрабатываемый материал	Стали	P						Условия резания	
	Нержавеющие стали	M						●	Непрерывное
	Чугуны	K						⊖	Универсальное
	Цветные металлы	N	⊖	⊖	●	⊖	⊕	⊕	Прерывистое
	Жаропрочные сплавы, титан	S							
	Материалы с повышенной твердостью	H							

Форма СМП	Модель	Без покрытия	Размеры (мм)					Условия резания	
		K10	l	d	t	r	d ₁	fn (мм/об)	ap (мм)
	09T302-AL		9.3	9.525	3.97	0.2	4.4	0.02 - 0.30	0.10 - 4.00
	09T304-AL	●	9.1	9.525	3.97	0.4	4.4	0.04 - 0.40	0.10 - 5.00
	09T308-AL	●	8.7	9.525	3.97	0.8	4.4	0.03 - 0.40	0.10 - 5.00
	120404-AL	●	12.3	12.7	4.76	0.4	5.5	0.03 - 0.50	0.10 - 5.00
	120408-AL	●	11.9	12.7	4.76	0.8	5.5	0.04 - 0.60	0.15 - 5.50
	120416-AL			11.1	12.7	4.76	1.6	5.5	

Пластины для обработки цветных металлов и сплавов (положительная геометрия)

TC__60°

Ромб
Передний угол 7°

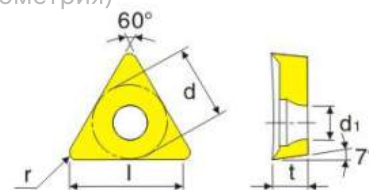

Обрабатываемый материал	Стали	P						Условия резания	
	Нержавеющие стали	M						●	Непрерывное
	Чугуны	K						⊖	Универсальное
	Цветные металлы	N	⊖	⊖	●	⊖	⊕	⊕	Прерывистое
	Жаропрочные сплавы, титан	S							
	Материалы с повышенной твердостью	H							

Форма СМП	Модель	Без покрытия	Размеры (мм)					Условия резания	
		K10	l	d	t	r	d ₁	fn (мм/об)	ap (мм)
	090202-AL	●	9.1	5.56	2.38	0.2	2.5	0.01 - 0.12	0.05 - 3.00
	090204-AL	●	8.6	5.56	2.38	0.4	2.5	0.02 - 0.15	0.10 - 4.00
	110202-AL	●	10.5	6.35	2.38	0.2	2.8	0.02 - 0.20	0.05 - 4.00
	110204-AL	●	10.0	6.35	2.38	0.4	2.8	0.03 - 0.30	0.10 - 4.00
	11T0208-AL	●	9.0	6.35	2.38	0.8	2.8	0.03 - 0.40	0.10 - 5.00
	16T302-AL	●	15.0	9.525	3.97	0.2	4.4	0.02 - 0.30	0.05 - 5.00
	16T304-AL	●	15.5	9.525	3.97	0.4	4.4	0.03 - 0.40	0.10 - 5.50
	16T308-AL	●	14.5	9.525	3.97	0.8	4.4	0.03 - 0.50	0.10 - 5.50
	16T312-AL	●	13.5	9.525	3.97	1.2	4.4	0.04 - 0.60	0.15 - 5.50
	16T316-AL	●	12.5	9.525	3.97	1.6	4.4	0.05 - 0.80	0.15 - 5.50

Пластины для обработки цветных металлов и сплавов (положительная геометрия)

VB__35°

Ромб
Передний угол 7°

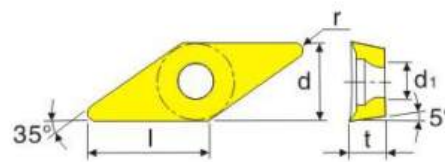

Обрабатываемый материал	Стали	P						Условия резания ● Непрерывное ⊕ Универсальное ⊗ Прерывистое
	Нержавеющие стали	M						
	Чугуны	K						
	Цветные металлы	N	⊕	⊕	●	⊕	⊗	
	Жаропрочные сплавы, титан	S						
	Материалы с повышенной твердостью	H						

Форма СМП	Модель	Без покрытия	Размеры (мм)					Условия резания	
		K10	l	d	t	r	d ₁	f _n (мм/об)	а _p (мм)
	110302-AL	●	10.5	6.35	3.18	0.2	2.8	0.02 - 0.15	0.05 - 3.00
	110304-AL	●	10.0	6.35	3.18	0.4	2.8	0.02 - 0.15	0.10 - 4.00
	110308-AL		9.0	6.35	3.18	0.8	2.8	0.03 - 0.18	0.10 - 5.00
	160402-AL		16.1	9.525	4.76	0.2	4.4	0.03 - 0.30	0.05 - 4.00
	160404-AL	●	15.6	9.525	4.76	0.4	4.4	0.03 - 0.40	0.10 - 5.00
	160408-AL	●	14.6	9.525	4.76	0.8	4.4	0.03 - 0.50	0.10 - 5.00

Пластины для обработки цветных металлов и сплавов (положительная геометрия)

VC__35°

Ромб
Передний угол 7°

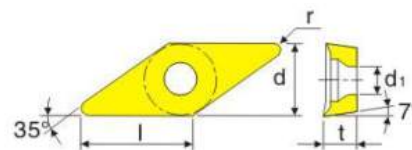

Обрабатываемый материал	Стали	P						Условия резания ● Непрерывное ⊕ Универсальное ⊗ Прерывистое
	Нержавеющие стали	M						
	Чугуны	K						
	Цветные металлы	N	⊕	⊕	●	⊕	⊗	
	Жаропрочные сплавы, титан	S						
	Материалы с повышенной твердостью	H						

Форма СМП	Модель	Без покрытия	Размеры (мм)					Условия резания	
		K10	l	d	t	r	d ₁	f _n (мм/об)	а _p (мм)
	110302-AL	●	10.5	6.35	3.18	0.2	2.8	0.02 - 0.20	0.05 - 3.00
	110304-AL	●	10.0	6.35	3.18	0.4	2.8	0.02 - 0.25	0.10 - 4.00
	110308-AL	●	9.0	6.35	3.18	0.8	2.8	0.03 - 0.30	0.10 - 5.00
	160402-AL	●	16.1	9.525	4.76	0.2	4.4	0.02 - 0.30	0.05 - 5.00
	160404-AL	●	15.6	9.525	4.76	0.4	4.4	0.03 - 0.40	0.10 - 5.00
	160408-AL	●	14.0	9.525	4.76	0.8	4.4	0.03 - 0.50	0.10 - 5.00
	160412-AL	●	13.6	9.525	4.76	1.2	4.4	0.04 - 0.60	0.10 - 5.00

RC

Круг

Передний угол 7°

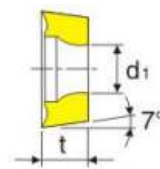

Обрабатываемый материал	Стали	P						Условия резания ● Непрерывное ⊕ Универсальное ⊗ Прерывистое
	Нержавеющие стали	M						
	Чугуны	K						
	Цветные металлы	N	⊕	⊕	●	⊕	⊗	
	Жаропрочные сплавы, титан	S						
Материалы с повышенной твердостью	H							

Форма СМП	Модель	Без покрытия	Размеры (мм)					Условия резания	
		K10	l	d	t	r	d ₁	f _n (мм/об)	а _p (мм)
	0803M0-AL	●	-	8.0	3.18	-	3.35	0.05 - 0.25	0.50 - 2.50
	1003M0-AL	●	-	10.0	3.18	-	4.0	0.10 - 0.30	1.00 - 3.00
	08T3M0-AL		-	10.0	3.97	-	4.4	0.10 - 0.30	1.00 - 3.00
	1204M0-AL	●	-	12.0	4.76	-	5.5	0.10 - 0.35	1.00 - 3.50

диаметр пластины толщина, S код стружколома

R_MT 12 04 - -

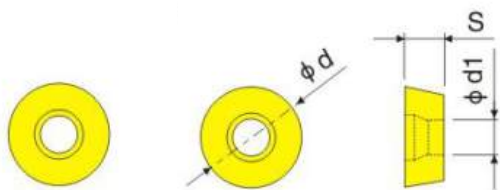

R_T__	08T2__	1003__	10T3__	1204__	1605__
∅ d1 (мм)	8	10	10	12	16

Положительная геометрия ● в наличии ○ под заказ

Обрабатываемый материал	Стали	P								Условия резания
	Нержавеющие стали	M								● Непрерывное
	Чугуны	K								⊕ Универсальное
	Цветные металлы	N	⊕	⊕	●	⊕	⊕			⊗ Прерывистое
	Жаропрочные сплавы, титан	S								
	Материалы с повышенной твердостью	H								

Форма СМП	Модель	Размеры			Материал						Внешний вид
		D1	S1	L1	LF618	LF6008	LF6018	LF6028	LDA	Uncoated	
	RCMT06T2MO	6	2.45	2.8			●				
	RPMT08T2MOE-JS	8	2.78	2.94			●				
	RPMT10T3MOE-JS	10	3.97	4.4			●				
	RPMT1204MOE-JS	12	4.76	4.4			●				
	RPMT1606MOE-JS	16	6.35	5.5			●				
	RPMT08T2M0-TT	8	2.78	2.94			●				
	RPMW1003M0-TT	10	3.18	4.4			●				
	RPMW1204M0-TT	12	4.76	4.4			●				
	RPMT1003MO-TT	10	3.18	4.4	●						
	RPMT10T3MO-TT	10	3.97	4.4			●				
	RPMT1204MO-TT	12	4.76	4.4			●				
	RPMT1606MO-TT	16	6.35	5.5			●				
	RPMT1204MO-TT	12	4.76	4.4	●						
	RDMT1204MO-MQ	12	4.76	4.4			●				

диаметр пластины толщина, S код стружколома

R_MT 12 04 - -

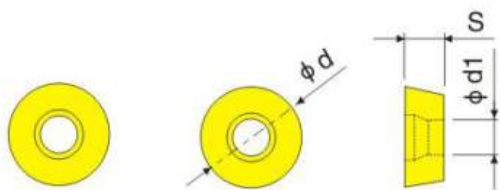

R_T__	08T2__	1003__	10T3__	1204__	1605__
Ø d1 (мм)	8	10	10	12	16

Положительная геометрия ● в наличии ○ под заказ

Обрабатываемый материал	Стали	P									Условия резания	
	Нержавеющие стали	M										● Непрерывное
	Чугуны	K										⊕ Универсальное
	Цветные металлы	N	⊕	⊕	●	⊕	⊕	⊕	⊕	⊕		⊗ Прерывистое
	Жаропрочные сплавы, титан	S										
	Материалы с повышенной твердостью	H										

Форма СМП	Модель	Размеры			Материал						Внешний вид
		D1	S1	L1	LF618	LF6008	LF6018	LF6028	LDA	Uncoated	
	RDMT1204MO - MQ	12	4.76	4.4				●			
	RDMT1204MO - MQ	12	4.76	4.4	●						
	RDMT08T2MOE-BM	8	2.78	2.94			●				
	RDMT10T3MOE-BM	10	3.97	4.4			●				
	RDMT1204MOE-BM	12	4.76	4.4			●				
	RDHX1003MOT	10	3.18	3.8			●				
	RDHX12T3MOT	12	3.97	3.8			●				

Пластины для корпусных фрез

APMT _ _ _ - H _

● в наличии ○ под заказ

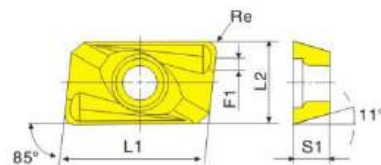

Фреза	Модель	Размеры					Материал					
		L1	L2	S1	F1	Re	LF618	LF6008	LF6018	LF6028	LDA	Uncoated
ВАР300	APMT1135PDER-H1	11	6.35	3.5	1.5	0.4			○		○	
ВАР400	APMT1604PDER-H1	17.5	9.525	4.76	1.7	0.4			○		○	
	APMT1604PDER-H2	17.5	9.525	4.76	1.7	0.8			●		●	

Пластины для корпусных фрез

APMT _ _ _ PDER - H2

● в наличии ○ под заказ

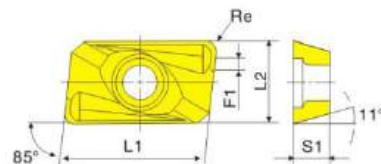
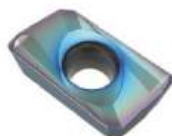

Фреза	Модель	Размеры						Материал					
		d	IC	L	W	S	r	LF618	LF6008	LF6018	LF6028	LDA	Uncoated
ВАР300	APMT1135PDER-H2	2.8	6.2	11	6.35	3.5	0.8	●					
ВАР400	APMT1604PDER-H2	4.4	9.25	17.5	9.525	4.76	0.8	●					

Пластины для корпусных фрез

APMT _ _ _ - M _

● в наличии ○ под заказ

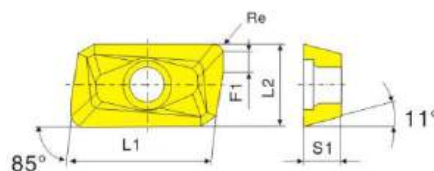

Фреза	Модель	Размеры					Материал					
		L1	L2	S1	F1	Re	LF618	LF6008	LF6018	LF6028	LDA	Uncoated
ВАР300	APMT1135PDER-M2	11	6.35	3.5	1.5	0.8			●		●	
ВАР400	APMT1604PDER-M2	16.5	9.525	4.76	1.7	0.8			●			
ВАР300	APMT1135PDER-G2	11	6.35	3.5	1.5	0.8						●
ВАР400	APMT1604PDER-G2	17.5	9.525	4.76	1.7	0.8						●

Пластины для корпусных фрез

APMT _ _ _ _ PDER - M2

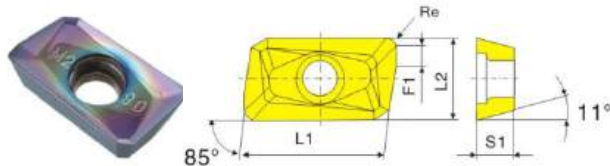

● в наличии ○ под заказ

Фреза	Модель	Размеры						Материал						
		L1	I.C	L	W	S	r	LF618	LF6008	LF6018	LF6028	LDA	Uncoated	
ВАР400	APMT1604PDER-M2	4.4	9.25	16.5	9.525	4.76	0.8	●						

Пластины для корпусных фрез

APMT _ _ _ - XM

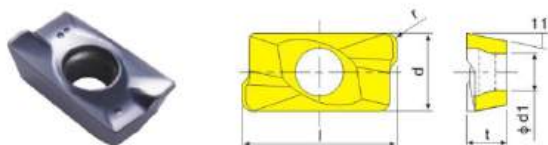

● в наличии ○ под заказ

Фреза	Модель	Размеры					Материал					
		L1	L2	S1	F1	Re	LF618	LF6008	LF6018	LF6028	LDA	Uncoated
ВАР300	APMT1135PDER-XM	11.3	6.35	3.5	1.5	0.4			●		●	
ВАР400	APMT1604PDER-XM	16.15	9.525	4.76	1.7	0.8			●		●	

Пластины для корпусных фрез

APMT1 _ _ _ _ PEER - XM

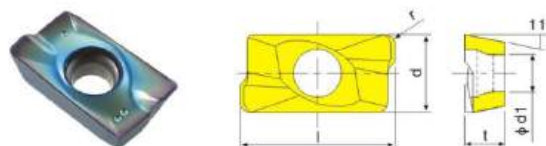

● в наличии ○ под заказ

Фреза	Модель	Размеры						Материал					
		d	I.C	L	W	S	r	LF618	LF6008	LF6018	LF6028	LDA	Uncoated
ВАР400	APMT1604PEER-XM	4.4	9.27	16.5	9.525	5.25	0.8	●					
ВАР400	APMT1605PEER-XM	4.4	9.33	16.5	9.525	5.25	0.8	●					

Пластины для корпусных фрез

APKT1____OPDER - GW

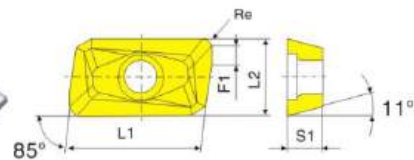

● в наличии ○ под заказ

Фреза	Модель	Размеры					Материал					
		L	IC	S	d	r	LF618	LF6008	LF6018	LF6028	LDA	Uncoated
ВАР400	APMT16042OPDER-GW	9	9.25	4.76	4.3	2			●			

Пластины для корпусных фрез

APKT____-HM

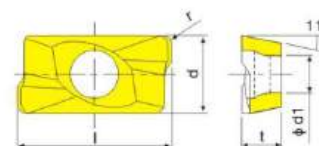

● в наличии ○ под заказ

Модель	Размеры						Материал					
	d	IC	L	W	S	r	LF618	LF6008	LF6018	LF6028	LDA	Uncoated
APKT160408-HM	4.4	9.55	17.5	9.525	5.77	0.8	●					

Пластины для корпусных фрез

AP__1003PD__

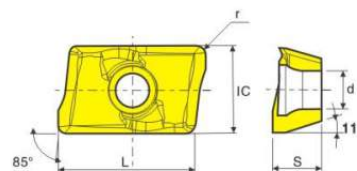
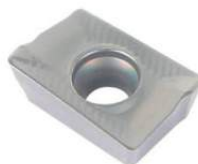

● в наличии ○ под заказ

Модель	Размеры					Материал					
	L	IC	S	d	r	LF618	LF6008	LF6018	LF6028	LDA	Uncoated
APKT160408-HM	11	6.67	3.55	2.8	0.5			●			

Пластины для корпусных фрез

JDMT _ _ _ _

● в наличии ○ под заказ

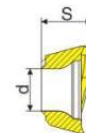
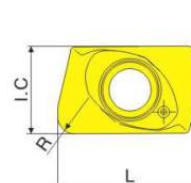

Модель	Размеры					Материал					
	L	I.C	S	d	r	LF618	LF6008	LF6018	LF6028	LDA	Uncoated
JDMT070204R	6.84	4.25	2.45	2.05	0.4			●			

Пластины для корпусных фрез

APKT _ _ _ _ - AL

● в наличии ○ под заказ

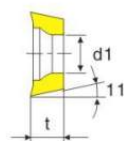
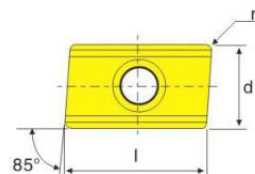

Модель	Размеры					Материал					
	L1	L2	S1	F1	Re	LF618	LF6008	LF6018	LF6028	LDA	Uncoated
APKT160404PDER-AL	16.88	9.8	4.76	4.4	0.4						●

Пластины для корпусных фрез

LNMU _ _ _ _ ZER-MJ

● в наличии ○ под заказ

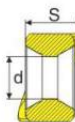

Модель	Размеры					Материал					
	L	I.C	S	d	r	LF618	LF6008	LF6018	LF6028	LDA	Uncoated
LNMU0303ZER-MJ	3.5	6.0	3.9	2.9	1.2	●		●			

Пластины для корпусных фрез

4NKT _____ - ML

● в наличии ○ под заказ

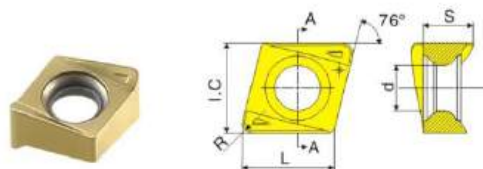

Модель	Размеры					Материал					
	L	I.C.	S	d	r	LF618	LF6008	LF6018	LF6028	LDA	Uncoated
4NKT060308R-ML	6.5	6.6	4.5	3.3	0.8				●		

Пластины для корпусных фрез

BLMP _____ - M

● в наличии ○ под заказ

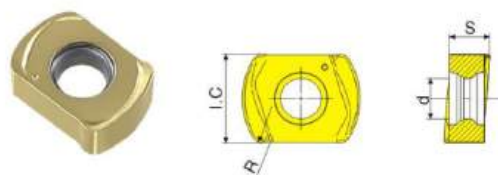

Модель	Размеры					Материал					
	L	I.C.	S	d	r	LF618	LF6008	LF6018	LF6028	LDA	Uncoated
BLMP0603R-M	6.4	6.6	3.42	3.2	1.0				●		
BLMP0904R-M	9.5	9.2	4.11	4.15	1.2				●		

Пластины для корпусных фрез

BLMP _____ - M

● в наличии ○ под заказ

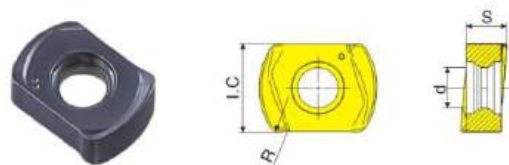

Модель	Размеры					Материал					
	L	I.C.	S	d	r	LF618	LF6008	LF6018	LF6028	LDA	Uncoated
BLMP0603R-M	6.5	6.4	3.42	3.2	1.0			●			

Пластины для корпусных фрез

RT _ _ _ _ - 81

● в наличии ○ под заказ

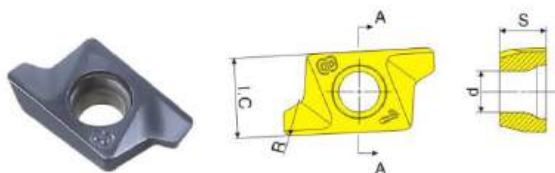

Модель	Размеры					Материал					
	L	I.C	S	d	r	LF618	LF6008	LF6018	LF6028	LDA	Uncoated
RT070204R-81	7.5	4.3	2.38	2.2	0.4			●			

Пластины для корпусных фрез

TRKN _ _ _ _ PDTR

● в наличии ○ под заказ

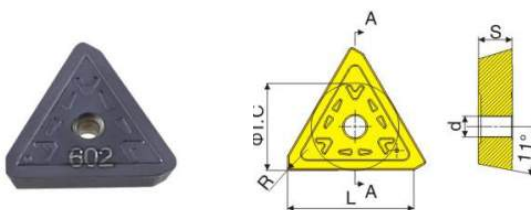

Модель	Размеры					Материал					
	L	I.C	S	d	r	LF618	LF6008	LF6018	LF6028	LDA	Uncoated
TRKN2204PDTR	12.5	4.76	4.76	2.0	1			●			

Пластины для корпусных фрез

ЗРКТ _ _ _ _ -М

● в наличии ○ под заказ

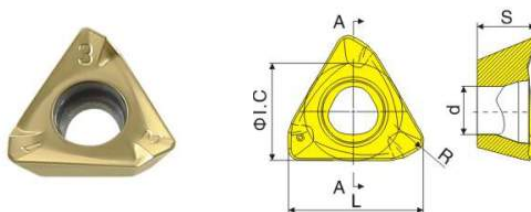

Модель	Размеры					P					M			K		Uncoated			
	L	I.C	S	d	r	LF9008	LF9018	LF9028	LF9218	LF9118	LF918	LF6008	LF6018	LF6028	LF6118		LF618	LF3018	LF3028
ЗРКТ150508R-М	15.5	10.7	4.96	5	0.8									●					

Пластины для корпусных фрез

ЗРКТ ___-М

● в наличии ○ под заказ

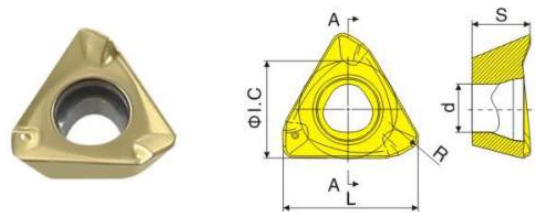

Модель	Размеры					P						M					K		Uncoated
	L	I.C.	S	d	r	LF9008	LF9018	LF9028	LF9218	LF9118	LF918	LF6008	LF6018	LF6028	LF6118	LF618	LF3018	LF3028	
ЗРКТ100408R-M	10.5	6.9	4.0	3.5	0.8										●				

Пластины для корпусных фрез

SE __1204 ___-___

● в наличии ○ под заказ

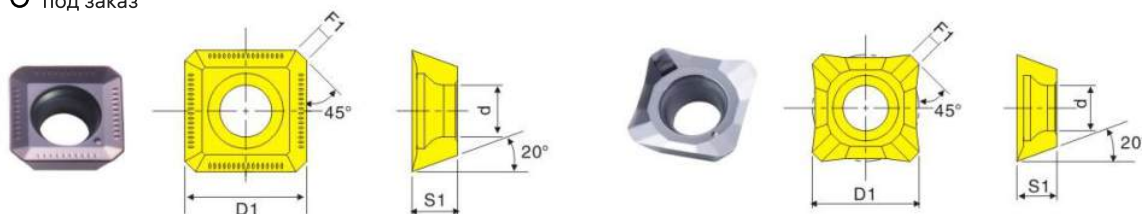

Фреза	Модель	Размеры				Материал					
		D1	d	S1	F1	LF618	LF6008	LF6018	LF6028	LDA	Uncoated
KM12	SEKT1204AFTN-XM	12.7	5.4	4.76	1.6			●		●	
KM12	SEHT1204AFFN-AL	12.7	5.4	4.76	1.6						●

Пластины для корпусных фрез

SE __1203 ___-___

● в наличии ○ под заказ

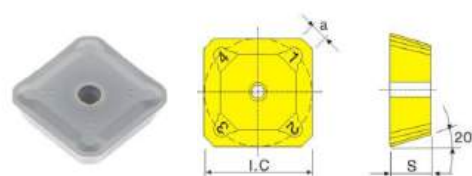

Модель	Размеры					Материал					
	L	I.C.	S	d	r	LF618	LF6008	LF6018	LF6028	LDA	Uncoated
SEET1203AFEN	12.55	12.55	3.18	/	0.8			●			

Пластины для корпусных фрез

SDMT ___12- PH

● в наличии ○ под заказ

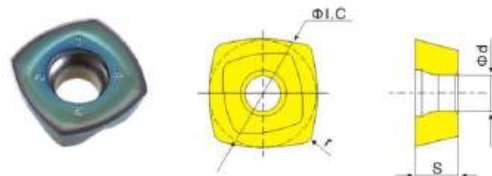

Модель	Размеры					Материал					
	L	I.C	S	d	r	LF618	LF6008	LF6018	LF6028	LDA	Uncoated
SDMT150512-PH	15.95	15.93	5.65	5.56	1.2	●					

Пластины для корпусных фрез

SDMT ___12- PH

● в наличии ○ под заказ

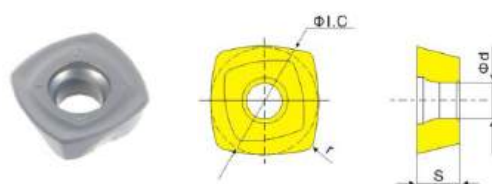

Модель	Размеры					Материал					
	L	I.C	S	d	r	LF618	LF6008	LF6018	LF6028	LDA	Uncoated
SDMT120512-PH	12.7	12.7	5.65	4.3	1.2			●			
SDMT150512-PH	15.95	15.95	5.65	5.5	1.2			●			

Пластины для корпусных фрез

ONMU _____

● в наличии ○ под заказ

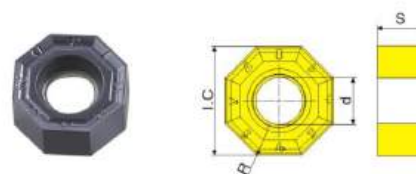

Модель	Размеры				Материал					
	I.C	S	d	r	LF618	LF6008	LF6018	LF6028	LDA	Uncoated
ONMU050504	13	5.15	5.55	0.4			●			

Пластины для корпусных фрез

WNMU ___ EN - GM

● в наличии ○ под заказ

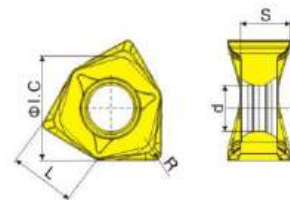

Модель	Размеры					P						M				K		Uncoated	
	L	I.C	S	d	r	LF9008	LF9018	LF9028	LF9218	LF9118	LF918	LF6008	LF6018	LF6028	LF6118	LF618	LF3018		LF3028
WNMU080608EN-GM	8.55	14	8.3	6.16	0.8								●						

Пластины для корпусных фрез

JDMW ___

● в наличии ○ под заказ

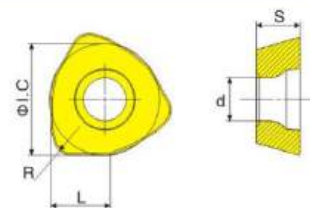

Модель	Размеры					P						M				K		Uncoated	
	L	I.C	S	d	r	LF9008	LF9018	LF9028	LF9218	LF9118	LF918	LF6008	LF6018	LF6028	LF6118	LF618	LF3018		LF3028
JDMW120420	6.5	12.3	4.76	4.73	2.0								●						

Пластины для U-образных фрез

WCMX ___ - SF

● в наличии ○ под заказ

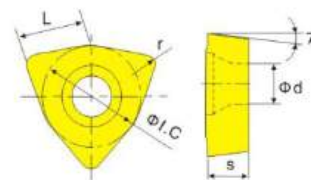

Модель	Размеры					P						M				K		Uncoated	
	L	I.C	S	d	r	LF9008	LF9018	LF9028	LF9218	LF9118	LF918	LF6008	LF6018	LF6028	LF6118	LF618	LF3018		LF3028
WCMX030208-SF	3.8	5.56	2.38	2.8	0.8								●						
WCMX040208-SF	4.3	6.35	2.38	3.1	0.8								●						
WCMX050308-SF	5.4	7.94	3.18	3.2	0.8								●						
WCMX06T308-SF	6.5	9.525	3.97	3.7	0.8								●						
WCMX080412-SF	8.7	12.7	4.76	4.3	1.2								●						

Пластины для U-образных сверл

WCMX ___ - MF

● в наличии ○ под заказ

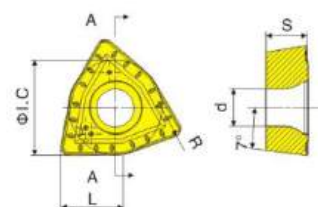

Модель	Размеры					P						M				K		Uncoated	
	L	I.C	S	d	r	LF9008	LF9018	LF9028	LF9218	LF9118	LF918	LF6008	LF6018	LF6028	LF6118	LF618	LF3018		LF3028
WCMX030208-MF	3.8	5.56	2.38	2.8	0.8									●	●				
WCMX040208-MF	4.3	6.35	2.38	3.1	0.8									●	●				
WCMX050308-MF	5.4	7.94	3.18	3.2	0.8									●	●				
WCMX06T308-MF	6.5	9.525	3.97	3.7	0.8									●	●				
WCMX080412-MF	8.7	12.7	4.76	4.3	1.2									●	●				

Пластины для U-образных сверл

WCMT ___ - SF

● в наличии ○ под заказ

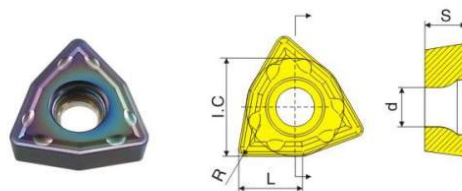

Модель	Размеры					P						M					K		Uncoated
	L	I.C	S	d	r	LF9008	LF9018	LF9028	LF9218	LF9118	LF918	LF6008	LF6018	LF6028	LF6118	LF618	LF3018	LF3028	
WCMT030208-SF	3.8	5.56	2.38	2.8	0.8												●		
WCMT040208-SF	4.3	6.35	2.38	3.1	0.8												●		
WCMT050308-SF	5.4	7.94	3.18	3.2	0.8												●		
WCMT06T308-SF	6.5	9.525	3.97	3.7	0.8												●		
WCMT080412-SF	8.7	12.7	4.76	4.3	1.2												●		

Пластины для U-образных сверл

SPMG ___ - TG

● в наличии ○ под заказ

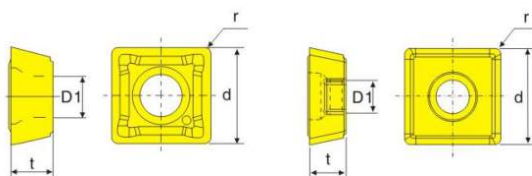
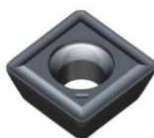

Модель	Размеры				P						M					K		Uncoated
	D	t	r	D1	LF9008	LF9018	LF9028	LF9218	LF9118	LF918	LF6008	LF6018	LF6028	LF6118	LF618	LF3018	LF3028	
SPMG050204-TG	5	2.38	0.4	2.25								●						
SPMG060204-TG	6	2.38	0.4	2.61								●						
SPMG07T308-TG	7.94	3.97	0.8	2.85								●						
SPMG090408-TG	9.8	4.76	0.8	4.05								●						
SPMG110408-TG	11.5	4.76	0.8	4.45								●						
SPMG120408-TG	12.7	4.76	0.8	4.45								●						

Пластины для U-образных сверл

SPMG ___ - DK

● в наличии ○ под заказ

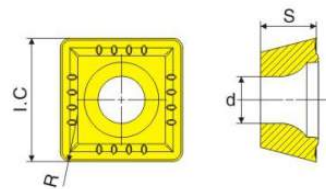
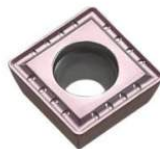

Модель	Размеры				P						M				K		Uncoated	
	D	t	r	D1	LF9008	LF9018	LF9028	LF9218	LF9118	LF918	LF6008	LF6018	LF6028	LF6118	LF618	LF3018		LF3028
SPMG050204-DK	5	2.38	0.4	2.25								●			●			
SPMG060204-DK	6	2.38	0.4	2.61								●			●			
SPMG07T308-DK	7.94	3.97	0.8	2.85								●			●			
SPMG090408-DK	9.8	4.76	0.8	4.05								●			●			
SPMG110408-DK	11.5	4.76	0.8	4.45								●			●			

Пластины для U-образных сверл

SOMT ___ - DQ

● в наличии ○ под заказ

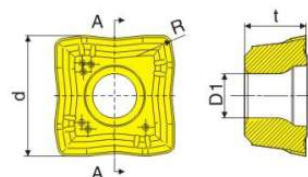

Модель	Размеры				P						M				K		Uncoated	
	D	t	r	D1	LF9008	LF9018	LF9028	LF9218	LF9118	LF918	LF6008	LF6018	LF6028	LF6118	LF618	LF3018		LF3028
SOMT050204-DQ	4.9	2.38	0.4	2.25								●						
SOMT060204-DQ	5.7	2.38	0.4	2.60								●						
SOMT070306-DQ	6.8	2.80	0.6	2.60								●						
SOMT08T306-DQ	7.9	3.97	0.6	2.85								●						
SOMT09T308-DQ	9.2	3.97	0.8	3.80								●						
SOMT11T308-DQ	11.0	3.97	0.8	3.80								●						
SOMT130408-DQ	12.8	4.40	0.8	4.40								●						
SOMT150510-DQ	15.0	4.80	1.0	5.40								●						

Пластины для U-образных сверл

SOMG ___ - TG

● в наличии ○ под заказ

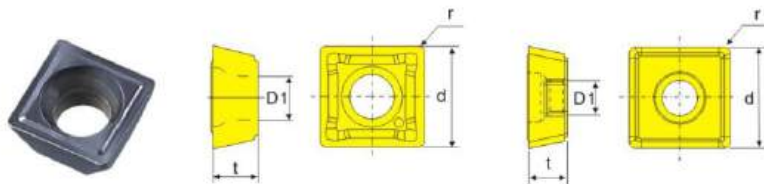

Модель	Размеры					P						M				K		Uncoated	
	L	I.C	S	d	r	LF9008	LF9018	LF9028	LF9218	LF9118	LF918	LF6008	LF6018	LF6028	LF6118	LF618	LF3018		LF3028
SOMG040202-TG	1.9	4.0	1.82	2.0	0.2								●						

Пластины для U-образных сверл

SPMG ___ - TG

● в наличии ○ под заказ

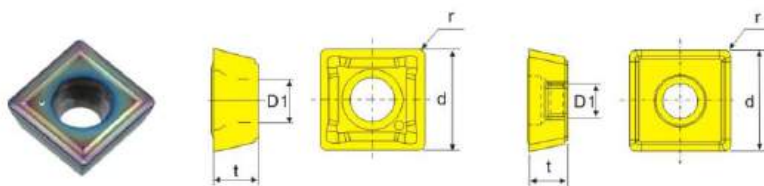

Модель	Размеры				P						M				K		Uncoated	
	D	t	r	D1	LF9008	LF9018	LF9028	LF9218	LF9118	LF918	LF6008	LF6018	LF6028	LF6118	LF618	LF3018		LF3028
SPMG050204-TG	5	2.38	0.4	2.25												●		
SPMG060204-TG	6	2.38	0.4	2.61														
SPMG07T308-TG	7.94	3.97	0.8	2.85														
SPMG090408-TG	9.8	4.76	0.8	4.05														
SPMG110408-TG	11.5	4.76	0.8	4.45														

Пластины для U-образных сверл

SPMG ___ - PD

● в наличии ○ под заказ

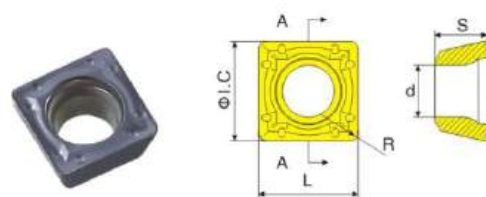

Модель	Размеры					P						M				K		Uncoated	
	L	I.C	S	d	r	LF9008	LF9018	LF9028	LF9218	LF9118	LF918	LF6008	LF6018	LF6028	LF6118	LF618	LF3018		LF3028
SPMG040204-PD	2.48	4.7	2.38	2.45	0.4								●						

Пластины для U-образных сверл

QCMT ___ - CM

● в наличии ○ под заказ

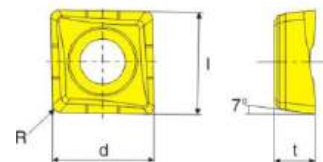

Модель	Размеры				P						M				K		Uncoated	
	D	t	r	D1	LF9008	LF9018	LF9028	LF9218	LF9118	LF918	LF6008	LF6018	LF6028	LF6118	LF618	LF3018		LF3028
QCMT040104-CM	4.4	6.4	1.7	0.4								●						
QCMT050204-CM	5.6	5.6	2.1	0.4								●						
QCMT060204-CM	6.4	6.4	2.38	0.4								●						
QCMT070304-CM	7.5	7.5	3.18	0.4								●						
QCMT080304-CM	8.4	8.4	3.18	0.4								●						
QCMT10T304-CM	10.5	10.5	3.97	0.4								●						





Концевые фрезы



Цельная твердосплавная фреза

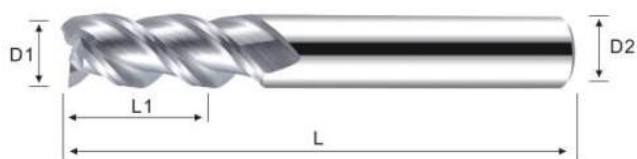

- 01 Острая режущая кромка
- 02 Для обработки алюминиевого сплава
- 03 Может использоваться для обработки меди, стали и других материалов.

Технические параметры

Модель	Диаметр D1	Длина рабочей части L1	Общая длина L	Диаметр хвостовика D2
1*4*3*50	1	3	50	4
1.5*4*4*50	1.5	4	50	4
2*4*6*50	2	6	50	4
2.5*4*8*50	2.5	8	50	4
3*4*11*50	3	11	50	4
4*4*13*50	4	13	50	4
5*6*17*50	5	17	50	6
6*6*17*50	6	17	50	6
8*8*22*60	8	22	60	8
10*10*27*75	10	27	75	10
12*12*32*75	12	32	75	12
14*14*37*100	14	37	100	14
16*16*40*100	16	40	100	16
18*18*45*100	18	45	100	18
20*20*48*100	20	48	100	20
3*4*16*75	3	16	75	4
4*4*16*75	4	16	75	4
5*6*20*75	5	20	75	6
6*6*20*75	6	20	75	6
8*8*35*100	8	35	100	8
10*10*40*100	10	40	100	10
12*12*45*100	12	45	100	12
16*16*70*150	16	70	150	16

Концевые фрезы с плоским торцом (2, 4 зуба)



01 Обработка стали твердостью ниже HRC50, нержавеющей стали

02 Нанопокрытие TiAlN

03 Может использоваться для обработки меди, никелевых и титановых сплавов, литого алюминия и других материалов.

Технические параметры

Модель	Диаметр D1	Длина рабочей части L1	Общая длина L	Диаметр хвостовика D2
1*4*3*50	1	3	50	4
1.5*4*4*50	1.5	4	50	4
2*4*6*50	2	6	50	4
2.5*4*8*50	2.5	8	50	4
3*4*8*50	3	8	50	4
3*6*8*50	3	8	50	6
4*4*10*50	4	10	50	4
4*6*10*50	4	10	50	6
5*6*13*50	5	13	50	6
6*6*15*50	6	15	50	6
8*8*25*60	8	25	60	8
10*10*30*75	10	30	75	10
12*12*30*75	12	30	75	12
14*14*40*100	14	40	100	14
16*16*40*100	16	40	100	16
18*18*45*100	18	45	100	18
20*20*45*100	20	45	100	20
3*4*12*75	3	12	75	4
4*4*16*75	4	16	75	4
4*6*16*75	4	16	75	6
5*6*20*75	5	20	75	6
6*6*24*75	6	24	75	6
8*8*32*100	8	32	100	8
10*10*40*100	10	40	100	10
12*12*48*100	12	48	100	12
16*16*64*150	16	64	150	16
20*20*80*150	20	80	150	20
4*6*16*100	4	16	100	6
6*6*24*100	6	24	100	6
8*8*32*150	8	32	150	8
10*10*40*150	10	40	150	10
12*12*48*150	12	48	150	12
16*16*64*200	16	64	200	16
20*20*80*200	20	80	200	20

Концевые фрезы с плоским торцом (2, 4 зуба)



- 01 Обработка стали твердостью ниже HRC60
- 02 Композитное нанопокрытие
- 03 Может использоваться для обработки нержавеющей стали, чугуна и других материалов

Технические параметры

Модель	Диаметр D1	Длина рабочей части L1	Общая длина L	Диаметр хвостовика D2
1*4*3*50	1	3	50	4
1.5*4*4*50	1.5	4	50	4
2*4*6*50	2	6	50	4
2.5*4*8*50	2.5	8	50	4
3*4*8*50	3	8	50	4
3*6*8*50	3	8	50	6
4*4*10*50	4	10	50	4
4*6*10*50	4	10	50	6
5*6*13*50	5	13	50	6
6*6*15*50	6	15	50	6
8*8*25*60	8	25	60	8
10*10*30*75	10	30	75	10
12*12*30*75	12	30	75	12
14*14*40*100	14	40	100	14
16*16*40*100	16	40	100	16
20*20*45*100	20	45	100	20
3*4*12*75	3	12	75	4
4*4*16*75	4	16	75	4
4*6*16*75	4	16	75	6
5*6*20*75	5	20	75	6
6*6*24*75	6	24	75	6
8*8*32*100	8	32	100	8
10*10*40*100	10	40	100	10
12*12*48*100	12	48	100	12
16*16*64*150	16	64	150	16
20*20*80*150	20	80	150	20
4*6*16*100	4	16	100	6
6*6*24*100	6	24	100	6
8*8*32*150	8	32	150	8
10*10*40*150	10	40	150	10

Концевые фрезы с плоским торцом (2, 4 зуба)

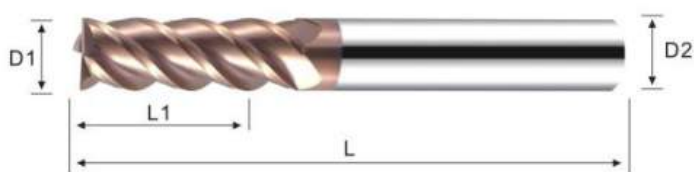

Технические параметры

- 01 Обработка стали твердостью ниже HRC60
- 02 Композитное нанопокрытие
- 03 Может использоваться для обработки нержавеющей стали, чугуна и других материалов
- 04 Спираль 45°

Модель	Диаметр D1	Длина рабочей части L1	Общая длина L	Диаметр хвостовика D2
1*4*3*50	1	3	50	4
1.5*4*4*50	1.5	4	50	4
2*4*6*50	2	6	50	4
2.5*4*8*50	2.5	8	50	4
3*4*8*50	3	8	50	4
3*6*8*50	3	8	50	6
4*4*10*50	4	10	50	4
4*6*10*50	4	10	50	6
5*6*13*50	5	13	50	6
6*6*15*50	6	15	50	6
8*8*25*60	8	25	60	8
10*10*30*75	10	30	75	10
12*12*30*75	12	30	75	12
14*14*40*100	14	40	100	14
16*16*40*100	16	40	100	16
20*20*45*100	20	45	100	20
3*4*12*75	3	12	75	4
4*4*16*75	4	16	75	4
4*6*16*75	4	16	75	6
5*6*20*75	5	20	75	6
6*6*24*75	6	24	75	6
8*8*32*100	8	32	100	8
10*10*40*100	10	40	100	10
12*12*48*100	12	48	100	12
16*16*64*150	16	64	150	16
20*20*80*150	20	80	150	20
4*6*16*100	4	16	100	6
6*6*24*100	6	24	100	6
8*8*32*150	8	32	150	8
10*10*40*150	10	40	150	10

Сферическая концевая фреза



- 01 Обработка стали твердостью ниже HRC50
- 02 Нанопокрывтие TiAlN
- 03 Может использоваться для обработки нержавеющей стали, чугуна и других материалов

Технические параметры

Модель	Радиус R	Диаметр D1	Длина рабочей части L1	Общая длина L	Диаметр хвостовика D2
R0.5*4*2*50	R0.5	1	2	50	4
R0.75*4*4*50	R0.75	1.5	4	50	4
R1*4*4*50	R1	2	4	50	4
R1.25*4*6*50	R1.25	2.5	6	50	4
R1.5*4*6*50	R1.5	3	6	50	4
R2*4*8*50	R2	4	8	50	4
R2.5*6*12*50	R2.5	5	12	50	6
R3*6*12*50	R3	6	12	50	6
R4*8*16*60	R4	8	16	60	8
R5*10*20*75	R5	10	20	75	10
R6*12*25*75	R6	12	25	75	12
R8*16*30*100	R8	16	30	100	16
R10*20*35*100	R10	20	35	100	20
R1.5*4*6*75	R1.5	3	6	75	4
R2*4*8*75	R2	4	8	75	4
R2*6*8*75	R2	4	8	75	6
R2.5*6*12*75	R2.5	5	12	75	6
R3*6*12*75	R3	6	12	75	6
R4*8*16*100	R4	8	16	100	8
R5*10*20*100	R5	10	20	100	10
R6*12*25*100	R6	12	25	100	12
R8*16*30*150	R8	16	30	150	16
R10*20*35*150	R10	20	35	150	20
R2*6*8*100	R2	4	8	100	6
R3*6*12*100	R3	6	12	100	6
R4*8*16*150	R4	8	16	150	8
R5*10*20*150	R5	10	20	150	10
R6*12*25*150	R6	12	25	150	12

Сферическая концевая фреза

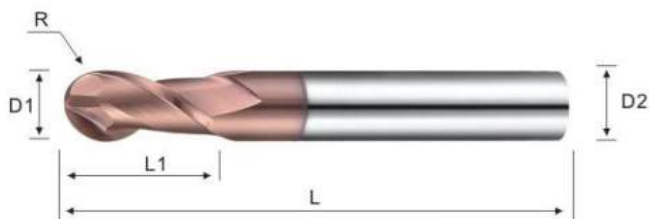

Технические параметры

- 01 Обработка стали твердостью ниже HRC60
- 02 Композитное нанопокрытие
- 03 Может использоваться для обработки нержавеющей стали, чугуна и других материалов

Модель	Радиус R	Диаметр D1	Длина рабочей части L1	Общая длина L	Диаметр хвостовика D2
R0.5*4*1*50	R0.5	1	1	50	4
R0.75*4*1.5*50	R0.75	1.5	1.5	50	4
R1*4*2*50	R1	2	2	50	4
R1.25*4*2.5*50	R1.25	2.5	2.5	50	4
R1.5*4*3*50	R1.5	3	3	50	4
R1.5*6*3*50	R1.5	3	3	50	4
R2*4*4*50	R2	4	4	50	4
R2*6*4*50	R2	4	4	50	6
R2.5*6*5*50	R2.5	5	5	50	6
R3*8*8*60	R3	6	6	50	6
R4*8*8*60	R4	8	8	60	8
R5*10*10*75	R5	10	10	75	10
R6*12*12*75	R6	12	12	75	12
R8*16*16*100	R8	16	16	100	16
R10*20*20*100	R10	20	20	100	20
R1.5*6*4.5*75	R1.5	3	4.5	75	6
R2*6*6*75	R2	4	6	75	6
R2.5*6*7.5*75	R2.5	5	7.5	75	6
R3*6*9*75	R3	6	9	75	6
R4*8*12*100	R4	8	12	100	8
R5*10*15*100	R5	10	15	100	10
R6*12*18*100	R6	12	18	100	12
R8*16*24*150	R8	16	24	150	16
R10*20*30*150	R10	20	30	150	20
R2*6*6*100	R2	4	6	100	6
R3*6*9*100	R3	6	9	100	6
R4*8*16*150	R4	8	16	150	8
R5*10*20*150	R5	10	20	150	10

Фреза со скругленной радиусом режущей кромкой



Технические параметры

- 01 Обработка стали твердостью ниже HRC50
- 02 Композитное нанопокрытие
- 03 Может использоваться для обработки нержавеющей стали, чугуна и других материалов

Модель	Радиус R	Диаметр D1	Длина рабочей части L1	Общая длина L	Диаметр хвостовика D2
1R0.2*4*2*50	R0.2	1	2	50	4
2R0.2*4*4*50	R0.2	2	4	50	4
3R0.2*4*6*50	R0.2	3	6	50	4
3R0.5*4*6*50	R0.5	3	6	50	4
4R0.2*4*8*50	R0.2	4	8	50	4
4R0.5*4*8*50	R0.5	4	8	50	4
4R1*4*8*50	R1	4	8	50	4
6R0.5*6*12*50	R0.5	6	12	50	6
6R1*6*12*50	R1	6	12	50	6
8R0.5*8*16*60	R0.5	8	16	60	8
8R1*8*16*60	R1	8	16	60	8
10R0.5*10*20*75	R0.5	10	20	75	10
10R1*10*20*75	R1	10	20	75	10
12R0.5*12*24*75	R0.5	12	24	75	12
12R1*12*24*75	R1	12	24	75	12
12R2*12*24*75	R2	12	24	75	12
4R0.2*6*8*75	R0.2	4	8	75	6
4R0.5*6*8*75	R0.5	4	8	75	6
6R0.5*6*12*100	R0.5	6	12	100	6
6R1*6*12*100	R1	6	12	100	6
8R0.5*8*16*100	R0.5	8	16	100	8
8R1*8*16*100	R1	8	16	100	8
10R0.5*10*20*100	R0.5	10	20	100	10
10R1*10*20*100	R1	10	20	100	10
12R0.5*12*24*100	R0.5	12	24	100	12
12R1*12*24*100	R1	12	24	100	12
12R2*12*24*100	R2	12	24	100	12

Фреза со скругленной радиусом режущей кромкой



Технические параметры

- 01 Обработка стали твердостью ниже HRC60
- 02 Композитное нанопокрытие
- 03 Может использоваться для обработки нержавеющей стали, чугуна и других материалов

Модель	Радиус R	Диаметр D1	Длина рабочей части L1	Общая длина L	Диаметр хвостовика D2
3R0.2*4*3*50	R0.2	3	3	50	4
3R0.5*4*3*50	R0.5	3	3	50	4
4R0.2*4*4*50	R0.2	4	4	50	4
4R0.5*4*4*50	R0.5	4	4	50	4
4R1*4*4*50	R1	4	4	50	4
6R0.5*6*6*50	R0.5	6	6	50	6
6R1*6*6*50	R1	6	6	50	6
8R0.5*8*8*60	R0.5	8	8	60	8
8R1*8*8*60	R1	8	8	60	8
10R0.5*10*10*75	R0.5	10	10	75	10
10R1*10*10*75	R1	10	10	75	10
12R0.5*12*12*75	R0.5	12	12	75	12
12R1*12*12*75	R1	12	12	75	12
12R2*12*12*75	R2	12	12	75	12
4R0.2*6*4*75	R0.2	4	4	75	6
4R0.5*6*4*75	R0.5	4	4	75	6
6R0.5*6*6*100	R0.5	6	6	100	6
6R1*6*6*100	R1	6	6	100	6
8R0.5*8*8*100	R0.5	8	8	100	8
8R1*8*8*100	R1	8	8	100	8
10R0.5*10*10*100	R0.5	10	10	100	10
10R1*10*10*100	R1	10	10	100	10
12R0.5*12*12*100	R0.5	12	12	100	12
12R1*12*12*100	R1	12	12	100	12
12R2*12*12*100	R2	12	12	100	12



Державки



www.10 112
201005050K08

Геометрические параметры державок















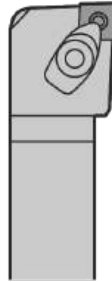
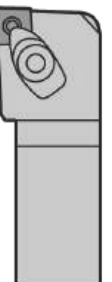
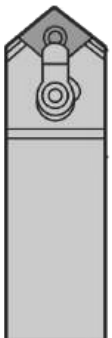



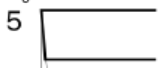































M		C		L		N		R																													
1 способ зажима		2 форма лезвия		3 угол врезки		4 угол зазора лезвия		5 направление																													
<p>модель W-типа</p> 	 <p>Четырехугольник C - 80°</p>	 <p>A-90°</p>  <p>B-75°</p>	<p>N 0°</p> 	L		  																															
<p>модель E-типа</p> 	 <p>Четырехугольник D - 55°</p>	 <p>C-90°</p>  <p>D-45°</p>	<p>B 5°</p> 	R																																	
<p>модель Q-типа</p> 	 <p>Параллелограмм K - 55°</p>	 <p>E-60°</p>  <p>F-91°</p>	<p>C 7°</p> 	R																																	
<p>модель C-типа</p> 	 <p>Круг R</p>	 <p>G-91°</p>  <p>G-91°</p>	<p>P 11°</p> 	N																																	
<p>модель JS-типа</p> 	 <p>Квадрат S</p>	 <p>J-93°</p>  <p>J2-93°</p>	R																																		
<p>модель P-типа</p> 	 <p>Треугольник T</p>	 <p>K-75°</p>  <p>L-95°</p>	R																																		
<p>модель D-типа</p> 	 <p>Четырехугольник V - 35°</p>	 <p>L2-95°</p>  <p>N-63°</p>	R																																		
<p>модель M-типа</p> 	 <p>Ломанный треугольник</p>	 <p>N3-63°</p>  <p>P-62.5°</p>	R																																		
<p>модель S-типа</p> 		 <p>Q-45°</p>  <p>S-45°</p>	R																																		
		 <p>V-72.5°</p>  <p>U-93°</p>	R																																		
		 <p>X-100°</p>  <p>Y-80°</p>	R																																		
25		25		M		12																															
6 высота (h)		7 ширина (b)		8 длина		9 длина режущей кромки																															
				<table border="1"> <thead> <tr> <th>обозначение, мм</th> <th>длина, мм</th> </tr> </thead> <tbody> <tr> <td>H</td> <td>100</td> </tr> <tr> <td>K</td> <td>125</td> </tr> <tr> <td>M</td> <td>150</td> </tr> <tr> <td>P</td> <td>170</td> </tr> <tr> <td>R</td> <td>200</td> </tr> <tr> <td>S</td> <td>250</td> </tr> <tr> <td>T</td> <td>300</td> </tr> </tbody> </table>		обозначение, мм	длина, мм	H	100	K	125	M	150	P	170	R	200	S	250	T	300	<table border="1"> <thead> <tr> <th>Диаметр вписанной окружности</th> <th>длина режущей кромки</th> </tr> </thead> <tbody> <tr> <td>3 9.525</td> <td></td> </tr> <tr> <td>4 12.7</td> <td></td> </tr> <tr> <td>5 15.875</td> <td></td> </tr> <tr> <td>6 19.05</td> <td></td> </tr> <tr> <td>8 25.4</td> <td></td> </tr> </tbody> </table>		Диаметр вписанной окружности	длина режущей кромки	3 9.525		4 12.7		5 15.875		6 19.05		8 25.4			
обозначение, мм	длина, мм																																				
H	100																																				
K	125																																				
M	150																																				
P	170																																				
R	200																																				
S	250																																				
T	300																																				
Диаметр вписанной окружности	длина режущей кромки																																				
3 9.525																																					
4 12.7																																					
5 15.875																																					
6 19.05																																					
8 25.4																																					

Схема комбинации-тип М

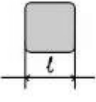
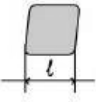
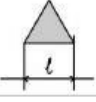

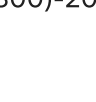
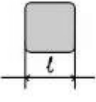
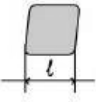
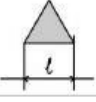

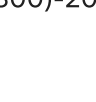
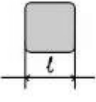
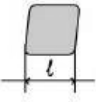
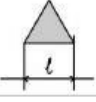

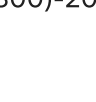
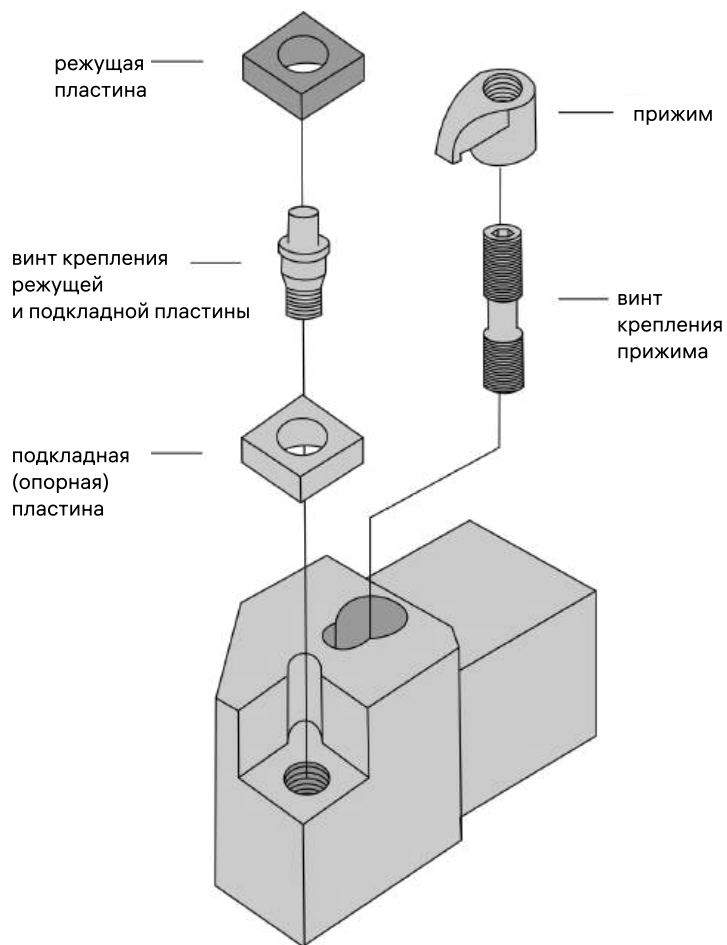
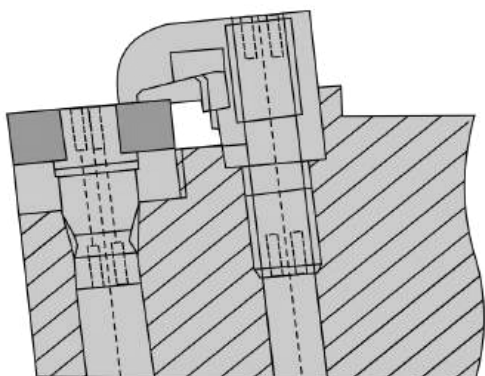

Содержание тип М

MCLNR/L	121	MTFNR/L	129
MCKNR/L	121	MTGNR/L	130
MCGNR/L	122	MVVNN	130
MCMNN	122	MVJNR/L	131
MCMNN-100	123	MVQNR/L	131
MCBNR/L	123	MVUNR/L	132
MCSNR/L	124	MDPNN	132
MCFNR/L	124	MDJNR/L	133
MWLNR/L	125	MDQNR/L	133
MSSNR/L	125	WTJNR/L	135
MSDNN	126	WTENN	135
MSKNR/L	126	WTBNR/L	136
MSBNR/L	127	WTQNR/L	136
MTJNR/L	127	WWLNR/L	137
MTBNR/L	128		
MTQNR/L	128		
MTENN	129		

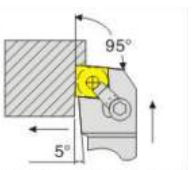
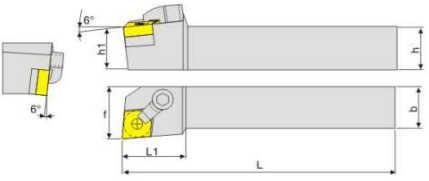
Тип М

MCLNR/R







Угол в плане 95°
Точение, торцевая обработка

												
Модель	Пластина 	Размеры						Детали				
		h	b	l	L1	h1	f	 подкладная пластина	 винт крепления пластин	 прижим	 винт крепления прижима	 ключ
MCLNR/L 1616H12	CN__1204__	16	16	100	16.0	16	20	SC1204	CTM617	HL1814	ML0625	L2.5 L3.0
MCLNR/L 2020K12		20	20	125	25.0	20	32					
MCLNR/L 2525M12		25	25	150	32.0	25	32					
MCLNR/L 3232P12	CN__1606__	32	32	170	40.0	32	32	SC1604	CTM822	HL2217	ML0830	L4.0 L5.0
MCLNR/L 4040R12		40	40	200	50.0	40	40					
MCLNR/L 2525M16		25	25	150	32.0	25	33					
MCLNR/L 3232P16		32	32	170	40.0	32	33					
MCLNR/L 4040R16	CN__1906__	40	40	200	50.0	40	40	SC1904	CTM1022	HL2217	ML0830	L4.0 L5.0
MCLNR/L 3232P19		32	32	170	40.0	32	32					
MCLNR/L 4040R19		40	40	200	50.0	40	40					

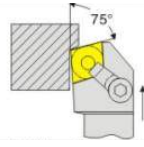
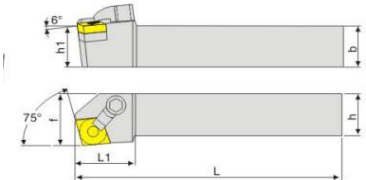
Тип М

MCKNR/R







Угол в плане 75°
Точение, торцевая обработка

												
Модель	Пластина 	Размеры						Детали				
		h	b	l	L1	h1	f	 подкладная пластина	 винт крепления пластин	 прижим	 винт крепления прижима	 ключ
MCKNR/L 2020K12	CN__1204__	20	20	125	32.0	20	25	SC1204	CTM617	HL1814	ML0625	L2.5 L3.0
MCKNR/L 2525M12		25	25	150	32.0	25	32					
MCKNR/L 3232P12		32	32	170	32.0	32	40					
MCKNR/L 2525M16	CN__1606__	25	25	150	32.0	25	33	SC1604	CTM822	HL2217	ML0830	L4.0 L5.0
MCKNR/L 3232P12		32	32	170	40.0	32	33					
MCKNR/L 4040R16		40	40	200	50.0	40	40					
MCKNR/L 3232P19	CN__1906__	32	32	170	40.0	32	40	SC1904	CTM1022	HL2217	ML0830	L4.0 L5.0
MCKNR/L 4040R19		40	40	200	50.0	40	40					

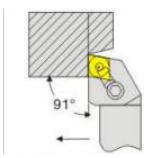
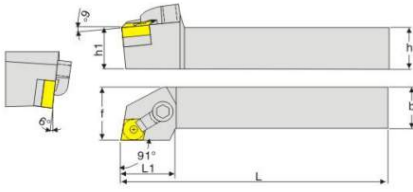
Тип М

MCGNR/R







Угол в плане 91°
Точение, торцевая обработка

												
Модель	Пластина	Размеры						Детали				
		h	b	l	L1	h1	f					
MCGNR/L 1616H12	CN__1204__	16	16	100	16.0	16	20	SC1204	CTM617	HL1814	ML0625	L2.5 L3.0
MCGNR/L 2020K12		20	20	125	32.0	20	25					
MCGNR/L 2525M12		25	25	150	32.0	25	32					
MCGNR/L 3232P12		32	32	170	32.0	32	40					
MCGNR/L 4040R12		40	40	200	50.0	40	40					
MCGNR/L 2525M16	CN__1606__	25	25	150	32.0	25	32	SC1604	CTM822	HL2217	ML0830	L4.0 L5.0
MCGNR/L 3232P16		32	32	170	32.0	32	40					
MCGNR/L 4040R16		40	40	200	50.0	40	40					
MCGNR/L 3232P19	CN__1906__	32	32	170	32.0	32	40	SC1904	CTM1022	HL2217	ML0830	L4.0 L5.0
MCGNR/L 4040R19		40	40	200	50.0	40	40					

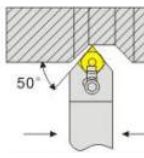
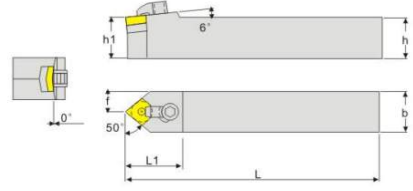
Тип М

MCMNN







Угол в плане 50°
Наружное точение

												
Модель	Пластина	Размеры						Детали				
		h	b	l	L1	h1	f					
MCMNN 1616K12	CN__1204__	16	16	100	16	16	7.5	SC1204	CTM617	HL1814	ML0625	L2.5 L3.0
MCMNN 2020K12		20	20	125	32	20	10					
MCMNN 2525M12		25	25	150	32	25	12.5					
MCMNN 3232P12		32	32	170	32	32	16					
MCMNN 4040R12		40	40	200	35	40	20					
MCMNN 3232P16	CN__1606__	32	32	170	35	32	16	SC1604	CTM822	HL2217	ML0830	L4.0 L5.0
MCMNN 4040R16		40	40	200	35	40	20					
MCMNN 4040R19		40	40	200	35	40	20					

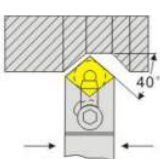
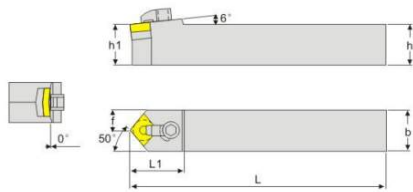
Тип М

MCMNN-100







Угол в плане 40°
Наружное точение

												
Модель	Пластина 	Размеры						Детали				
		h	b	l	L1	h1	f					
MCMNN 2020K12-100		20	20	125	32	20	10					
MCMNN 2525M12-100	CN __ 1204 __	25	25	150	32	25	12.5	SC1204	CTM617	HL1814	ML0625	L2.5 L3.0
MCMNN 3232P12-100		32	32	170	32	32	16					
MCMNN 3232P16-100	CN __ 1606 __	32	32	170	32	32	16	SC1604	CTM0822	HL2217	ML0830	L4.0 L5.0

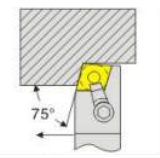
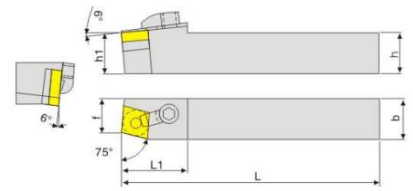
Тип М

MCBNR/L

Угол в плане 75°
Наружное точение

												
Модель	Пластина 	Размеры						Детали				
		h	b	l	L1	h1	f					
MCBNR/L 2020K12		20	20	125	32	20	17					
MCBNR/L 2525M12	CN __ 1204 __	25	25	150	32	25	22	SC1204	CTM617	HL1814	ML0625	L 2.5 3.0
MCBNR/L 3232P12		32	32	170	32	32	27					
MCBNR/L 2525M16		25	25	150	32	25	33					
MCBNR/L 3232P16	CN __ 1606 __	32	32	170	40	32	33	SC1604	CTM822	HL2217	ML0830	L 4.0 5.0

Тип М

MCSNR/L

Угол в плане 45°
Наружное точение

Модель	Пластина 	Размеры						Детали				
		h	b	l	L1	h1	f					
MCSNR/L 2020K12	CN __ 1204 __	20	20	125	32	20	25					L 2.5 3.0
MCSNR/L 2525M12		25	25	150	32	25	32					
MCSNR/L 3232P12		32	32	170	32	32	40					
MCSNR/L 3232P16	CN __ 1606 __	32	32	170	32	32	40					L 4.0 5.0
MCSNR/L 4040R16	CN __ 1906 __	40	40	200	35	40	50					L 4.0 5.0

Тип М

MCFNR/L

Угол в плане 91°
Наружное точение

Модель	Пластина 	Размеры						Детали				
		h	b	l	L1	h1	f					
MCFNR/L 2020K12	CN __ 1204 __	20	20	125	32	20	25					L 2.5 3.0
MCFNR/L 2525M12		25	25	150	32	25	32					
MCFNR/L 3232P12		32	32	170	32	32	40					
MCFNR/L 3232P19	CN __ 1906 __	32	32	170	36	32	40					L 4.0
MCFNR/L 4040R19		40	40	200	35	40	20					

Тип M

MWLNR/L

Угол в плане 95°
Наружное точение, обработка торцевой поверхности

Модель	Пластина	Размеры						Детали					
		h	b	l	L1	h1	f						
MWLNR/L 2020K06	WN__0604__	20	20	125	25	20	32	SW0603		CTM513	HL1814	ML0625	L2.0 3.0
MWLNR/L 2525M06		25	25	150	32	25	32						
MWLNR/L 3232P06		32	32	170	40	32	32						
MWLNR/L 2020K08	WN__0804__	20	20	125	25	20	32	SW0804		CTM617	HL1814	ML0625	L2.5 3.0
MWLNR/L 2525M08		25	25	150	32	25	32						
MWLNR/L 3232P08		32	32	170	40	32	32						
MWLNR/L 4040R08		40	40	200	35	40	20						

Тип M

MSSNR/L







Угол в плане 45°
Токарная обработка наруж. пов-стей и торцев. Обработка фасок.

Модель	Пластина	Размеры						Детали				
		h	b	l	L1	h1	f					
MSSNR/L 1616H12	SN__1204__	16	16	100	16	16	17	MS1204	CTM617	HL1814	ML0625	L2.5 3.0
MSSNR/L 2020K12		20	20	125	32	20	17					
MSSNR/L 2525M12		25	25	150	32	25	22					
MSSNR/L 3232P12		32	32	170	32	32	27					
MSSNR/L 3232P15	SN__1506__	32	32	170	32	32	40	MS1504	CTM0822	HL2114	ML0825	L3.0 4.0

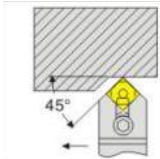
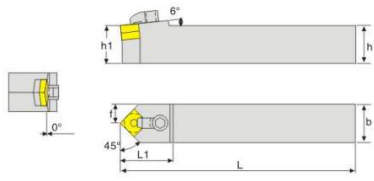
Тип М

MSDNN







Угол в плане 45°
Точение, наружное точение, обработка фасок.

												
Модель	Пластина 	Размеры						Детали				
		h	b	l	L1	h1	f					
MSDNN 1616H12	SN __ 1204 __	16	16	100	34	16	8	MS1204	CTM617	HL1814	ML0625	L2.5 3.0
MSDNN 2020K12		20	20	125	34	20	10					
MSDNN 2525M12		25	25	150	34	25	12.5					
MSDNN 3232P12	SN __ 1506 __	32	32	170	34	32	16	MS1504	CTM0822	HL2114	ML0825	L3.0 4.0
MSDNN 3232P15		32	32	170	34	32	16					
MSDNN 3232P19		32	32	170	34	32	16					
MSDNN 3232P19	SN __ 1906 __	32	32	170	34	32	16	MS1904	CTM1022	HL2114	ML0825	L4.0 5.0

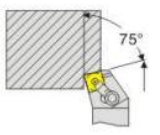
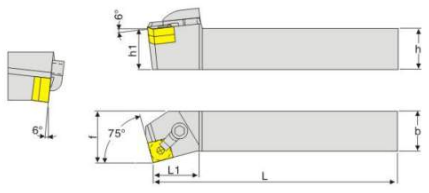
Тип М

MSKNR/L







Угол в плане 75°
Наружное точение

												
Модель	Пластина 	Размеры						Детали				
		h	b	l	L1	h1	f					
MSKNR/L 2020K12	SN __ 1204 __	20	20	125	29	20	25	MS1204	CTM617	HL1814	ML0625	L2.5 3.0
MSKNR/L 2525M12		25	25	150	29	25	32					
MSKNR/L 3232P12		32	32	170	29	32	40					
MSKNR/L 3232P15	SN __ 1506 __	32	32	170	29	32	40	MS1504	CTM0822	HL2114	ML0825	L3.0 4.0

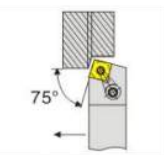
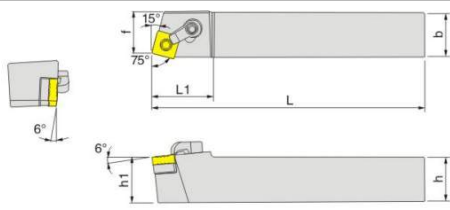
Тип М

MSBNR/L







Угол в плане 75°
Наружное точение

												
Модель	Пластина 	Размеры						Детали				
		h	b	l	L1	h1	f					
MSBNR/L 2020K12	SN __ 1204 __	20	20	125	32.5	20	17	MS1204	CTM617	HL1814	ML0625	L2.5 3.0
MSBNR/L 2525M12		25	25	150	32.5	25	22					
MSBNR/L 3232P12		32	32	170	32.5	32	27					
MSBNR/L 3232P15	SN __ 1506 __	32	32	170	32.5	32	27	MS1504	CTM0822	HL2114	ML0825	L3.0 4.0

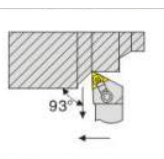
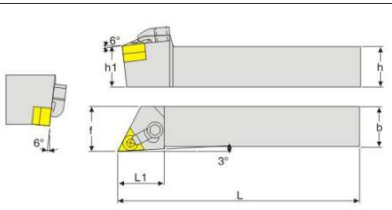
Тип М

MTJNR/L

Угол в плане 93°
Токарная и профильная обработка

												
Модель	Пластина 	Размеры						Детали				
		h	b	l	L1	h1	f					
MTJNR/L 1616H16	TN __ 1604 __	16	16	100	30	16	20	ST1603	CTM513	HL1814	ML0625	L2.0 3.0
MTJNR/2020K16		20	20	125	32	20	25					
MTJNR/L 2525M16		25	25	150	32	25	32					
MTJNR/L 3232P16		32	32	170	36	32	40					
MTJNR/L 4040R16		40	40	200	36	32	50					
MTJNR/L 2525M22	TN __ 2204 __	25	25	150	38	25	32	ST2204	CTM822	HL1917	ML0830	L2.5 4.0
MTJNR/L 3232P22		32	32	170	38	32	40					
MTJNR/L 4040R22		40	40	200	36	32	50					

Тип М

MTBNR/L

Угол в плане 75°
Наружное точение

Модель	Пластина 	Размеры						Детали				
		h	b	l	L1	h1	f					
MTBNR/L 2020H16		20	20	125	35	20	15.5					
MTBNR/L 2525K16	TN__1604__	25	25	150	35	25	20.5	ST1603	CTM513	HL1814	ML0625	L2.0 3.0

Тип М

MTQNR/L







Угол в плане 105°
Наружное точение

Модель	Пластина 	Размеры						Детали				
		h	b	l	L1	h1	f					
MTQNR/L 2020K16		20	20	125	26	20	25					
MTQNR/L 2525M16	TN__1604__	25	25	150	26	25	32	ST1603	CTM513	HL1814	ML0625	L2.0 3.0
MTQNR/L 3232P16		32	32	170	26	32	40					

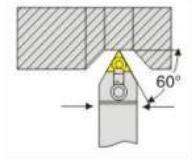
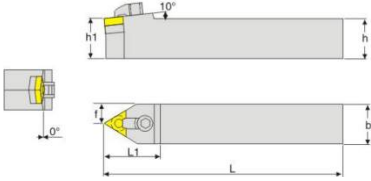
Тип М

MTENN









Угол в плане 60°
Наружное точение

												
Модель	Пластина 	Размеры						Детали				
		h	b	l	L1	h1	f					
MTENN 2020K16	TN__1604__	20	20	125	35	20	10	ST1603	CTM513	HL1814	ML0625	L2.0 3.0
MTENN 2525M16		25	25	150	35	25	12.5					
MTENN 3232P16		32	32	170	35	32	16					
MTENN 4040S16		40	40	250	35	40	20					
MTENN 2525M22	TN__2204__	25	25	150	38	25	12.5	ST2204	CTM822	HL1917	ML0830	L2.5 4.0
MTENN 3232P22		32	32	170	38	32	16					

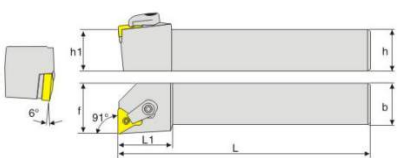
Тип М

MTFNR/L

Угол в плане 91°
Наружное точение

												
Модель	Пластина 	Размеры						Детали				
		h	b	l	L1	h1	f					
MTFNR/L 1616H16	TN__1604__	16	16	100	28	16	20	ST1603	CTM513	HL1814	ML0625	L2.0 3.0
MTFNR/L 2020K16		20	20	125	28	20	25					
MTFNR/L 2525M16		25	25	150	28	25	32					
MTFNR/L 3232P16		32	32	170	28	32	40					
MTFNR/L 2525M22	TN__2204__	25	25	150	32	25	32	ST2204	CTM822	HL1917	ML0830	L2.5 4.0
MTFNR/L 3232P22		32	32	170	32	32	32					

Тип М

MTGNR/L









Угол в плане 91°
Токарная и профильная обработка

												
Модель	Пластина 	Размеры						Детали				
		h	b	l	L1	h1	f	 подкладная пластина	 винт крепления пластин	 прижим	 винт крепления прижима	 ключ
MTGNR/L 1616H16		16	16	100	28	16	20					
MTGNR/L 2020K16	TN__1604__	20	20	125	28	20	25	ST1603	CTM513	HL1814	ML0625	L2.0 3.0
MTGNR/L 2525M16		25	25	150	28	25	32					
MTGNR/L 3232P22	TN__2204__	32	32	170	32	32	40	ST2204	CTM822	HL1917	ML0830	L2.5 4.0

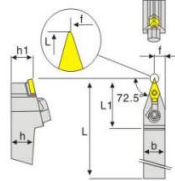
Тип М

MVVNN

Угол в плане 72.5°
Токарная и профильная обработка

												
Модель	Пластина 	Размеры						Детали				
		h	b	l	L1	h1	f	 подкладная пластина	 винт крепления пластин	 прижим	 винт крепления прижима	 ключ
MVVNN 2020K16		20	20	125	42	20	10					
MVVNN 2525M16	VN__1604__	25	25	150	42	25	12.5	SV1603	CTM513	HL2414	ML0630	L2.0 3.0
MVVNN 3232P16		32	32	170	42	32	16					

Тип М

MVJNR/L

Угол в плане 93°
Токарная и профильная обработка

Модель	Пластина 	Размеры						Детали				
		h	b	l	L1	h1	f					
MVJNR/L 2020K16	VN__1604__	20	20	125	42	20	20	SV1603	CTM513	HL2414	ML0630	L2.0 3.0
MVJNR/L 2525M16		25	25	150	42	25	25					
MVJNR/L 3232P16		32	32	170	42	32	32					

Тип М

MVQNR/L







Угол в плане 117.5°
Профильная обработка

Модель	Пластина 	Размеры						Детали				
		h	b	l	L1	h1	f					
MVQNR/L 2020K16	VN__1604__	20	20	125	40	20	25	SV1603	CTM513	HL2414	ML0625	L2.0 3.0
MVQNR/L 2525M16		25	25	150	40	25	32					
MVQNR/L 3232P16		32	32	170	40	32	40					

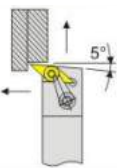
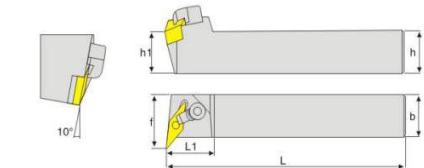
Тип М

MVUNR/L







Угол в плане 95°
Токарная и профильная обработка

												
Модель	Пластина	Размеры						Детали				
		h	b	l	L1	h1	f					
MVUNR/L 2020K16	VN__1604 __	20	20	125	21	20	25	SV1603	CTM513	HL2414	ML0625	L2.0 3.0
MVUNR/L 2525M16		25	25	150	21	25	32					
MVUNR/L 3232P16		32	32	170	21	32	40					

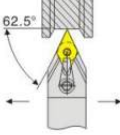
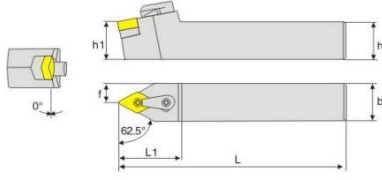
Тип М

MDPNN

Угол в плане 62.5°
Токарная и профильная обработка

												
Модель	Пластина	Размеры						Детали				
		h	b	l	L1	h1	f					
MDPNN 1616H11	DN__1104 __	16	16	100	36	16	8	SD1103	CTM513	HL1814	ML0625	L2.0 3.0
MDPNN 2020K11		20	20	125	36	20	10					
MDPNN 2525M11		25	25	150	36	25	12.5					
MDPNN 2020K15	DN__1504 __	20	20	125	42	20	10	SD1506	CTM619	HL2114	ML0625	L2.5 3.0
MDPNN 2525M15		25	25	150	42	25	12.5					
MDPNN 3232P15		32	32	170	42	32	16					
MDPNN 4040R15		40	40	200	42	32	20					

Тип М

MDJNR/L

Угол в плане 93°
Токарная и профильная обработка

Модель	Пластина	Размеры						Детали					
		h	b	l	L1	h1	f						
MDJNR/L 1616H11	DN __ 1104 __	16	16	100	30	16	20	SD1103				L2.0 3.0	
MDJNR/L 2020K11		20	20	125	30	20	25						
MDJNR/L 2525M11		25	25	150	30	25	32						
MDJNR/L 2020K15	DN __ 1504 __	20	20	125	38	20	25	SD1506				L2.5 3.0	
MDJNR/L 2525M15		25	25	150	38	25	32						
MDJNR/L 3232P15		32	32	170	38	32	40						
MDJNR/L 4040R15		40	40	200	38	40	50						

Тип М

MDQNR/L

Угол в плане 107.5°
Профильная обработка

Модель	Пластина	Размеры						Детали					
		h	b	l	L1	h1	f						
MDWNR/L 1616H11	DN __ 1104 __	16	16	100	30	16	20	SD1103				L2.0 3.0	
MDWNR/L 2020K15	DN __ 1504 __	20	20	125	36	20	25						
MDWNR/L 2525M15		25	25	150	36	25	32						
MDWNR/L 3232P15		DN __ 1506 __	32	32	170	36	32	40	SD1506				L2.5 3.0
MDWNR/L 4040R15	40	40	200	36	40	50							

Схема комбинации-тип W

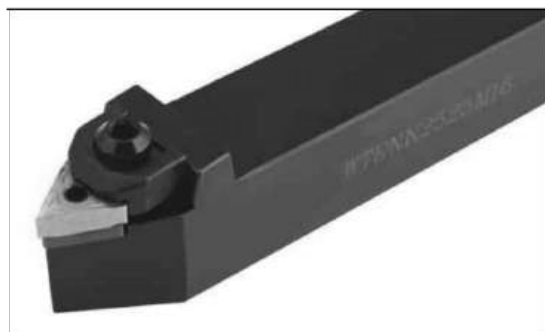
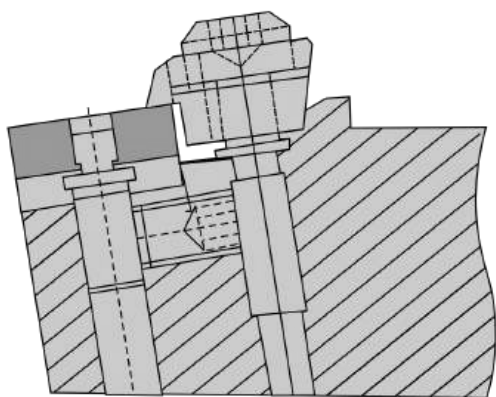

режущая пластина

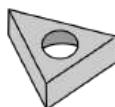

штифт крепления
подкладной
и режущей
пластины



подкладная
пластина

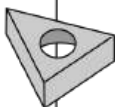

винт крепления прижима

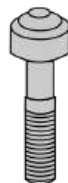

прижим

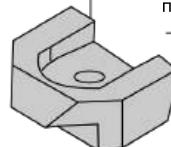

контргайка

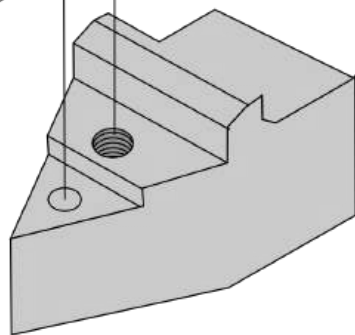

Тип W

WTJNR/L

Угол в плане 93°
Наружное точение, обработка торцев, профильная обработка

Модель	Пластина 	Размеры						Детали				
		h	b	l	L1	h1	f					
WTJNR/L 1616K16	TN__1604__	16	16	125	16	16	30	ST1603	CTM515	WT-Y	M5X25	L2.5 4.0
WTJNR/L 2020K16		20	20	125	25	20	33					
WTJNR/L 2525M16		25	25	150	32	25	33					
WTJNR/L 3232P16	TN__2204__	32	32	170	40	32	33	ST2204	CTM818	WT-Y	ML0830	L3.0 4.0
WTJNR/L 2525M22		25	25	150	32	25	35					
WTJNR/L 3232P22		32	32	170	40	32	35					

Тип W

WTENN

Угол в плане 93°
Наружное точение

Модель	Пластина 	Размеры						Детали				
		h	b	l	L1	h1	f					
WTENN 2020K16	TN__1604__	20	20	125	32	20	30	ST1603	CTM515	WT-Y	M5X25	L2.5 4.0
WTENN 2525M16		25	25	150	32	25	33					
WTENN 3232P16		32	32	170	32	32	33					

Тип W

WTBNR/L

Угол в плане 75°
Наружное точение

Модель	Пластина 	Размеры						Детали				
		h	b	l	L1	h1	f					
WTBNR/L 2020K16	TN__1604 __	20	20	125	32	20	15.5	ST1603	CTM515	WT-Y	M5X25	L2.5 4.0
WTBNR/L 2525M16		25	25	150	32	25	20.5					
WTBNR/L 3232P16		32	32	170	32	32	27.5					

Тип W

WTQNR/L

Угол в плане 105°
Наружное точение

Модель	Пластина 	Размеры						Детали				
		h	b	l	L1	h1	f					
WTQNR/L 2020K16	TN__1604 __	20	20	125	32	20	25	ST1603	CTM515	WT-Y	M5X25	L2.5 4.0
WTQNR/L 2525M16		25	25	150	32	25	32					
WTQNR/L 3232P16		32	32	170	32	32	40					

WWLNR/L

Угол в плане 95°
Наружное точение, обработка торцов

Модель	Пластина	Размеры						Детали					
		h	b	l	L1	h1	f						
WWLNR/L 2020K08	WN__0804 __	20	20	125	32	20	25	SW0804	CTM618	WW-Y	M6X25	L3.0 4.0	
WWLNR/L 2525M08		25	25	150	33	25	32						
WWLNR/L 3232P08		32	32	170	33	32	40						

Схема комбинации-тип S, JS

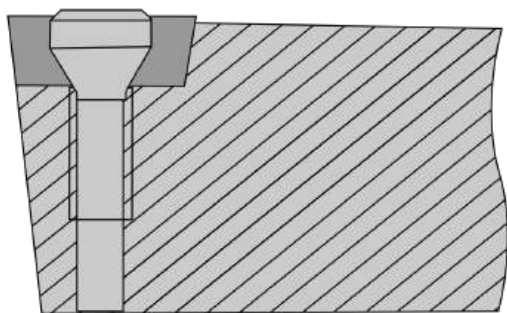

винт крепления
режущей пластины

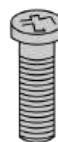

режущая пластина

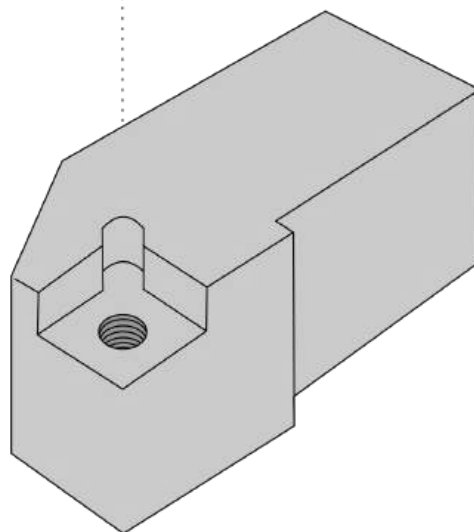
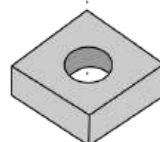

Содержание тип S,JS

SCLCR/L	140	STTCR/L	149
SCKCR/L	140	STWCR/L	149
SCFCR/L	141	SVJ*R/L	150
SCMCN	141	SVV*N	150
SCMCN-100	142	SVQ*R/L	151
SCBCR/L	142	SVU*R/L	151
SCACR/L	143	SRACR/L	152
SDJCR/L	143	SRDCN	152
SDACR/L	144	SRGCR/L	153
SDFCR/L	144	TBPR/L	153
SDQCR/L	145	KTKFR/L	154
SDNCN	145	TBPAR	154
SSBCR/L	146		
SSKCR/L	146		
SSSCR/L	147		
SSDCN	147		
STGCR/L	148		
STFCR/L	148		





Тип S

SCLCR/L

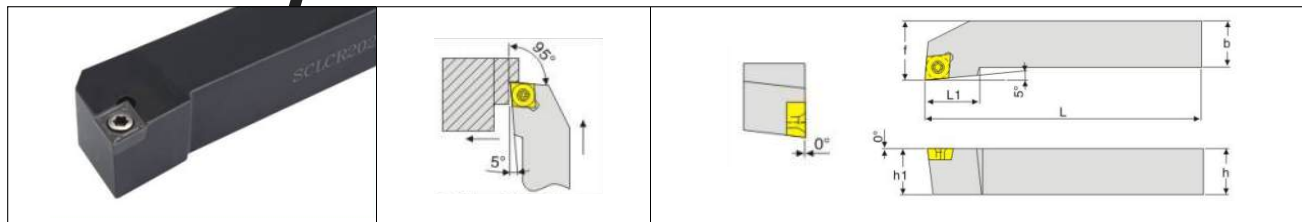
Угол в плане 95°
Наружное точение, подрезка торцев



Модель	Пластина 	Размеры						Детали	
		h	b	L	L1	h1	f	 ВИНТ	 КЛЮЧ
SCLCR/L 0808D06	CC__0602__	08	08	80	10	08	10	M2.5X6	T8
SCLCR/L 1010E06		10	10	100	12	10	10		
SCLCR/L 1212F09	CC__09T3__	12	12	100	16	12	16	M4X8	T15
SCLCR/L 1616H09		16	16	100	20	16	16		
SCLCR/L 2020K09		20	20	125	25	20	20		
SCLCR/L 2525M09		25	25	150	32	25	25		
SCLCR/L 2020K12	CC__1204__	20	20	125	25	20	25	M5X12	T20
SCLCR/L 2525M12		25	25	150	32	25	32		

Тип S

SCKCR/L

Угол в плане 75°
Подрезка торцев

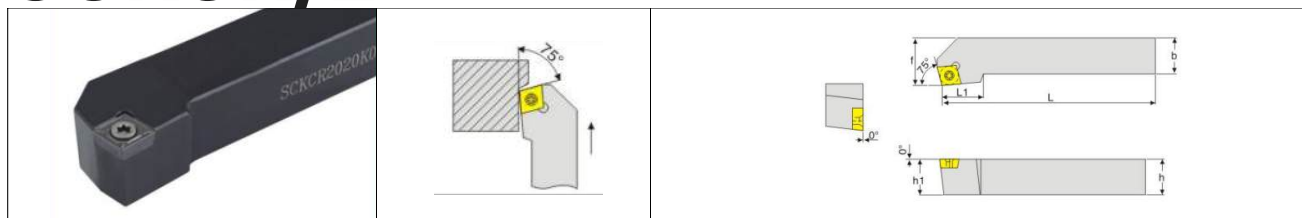





Модель	Пластина 	Размеры						Детали	
		h	b	L	L1	h1	f	 ВИНТ	 КЛЮЧ
SCKCR/L 2020K09	CC__09T3__	20	20	125	23	20	25	M4X10	T15
SCKCR/L 2525M09		25	25	150	23	25	32		
SCKCR/L 2020K12	CC__1204__	20	20	125	28	20	25	M5X12	T20
SCKCR/L 2525M12		25	25	100	28	25	32		

Тип S

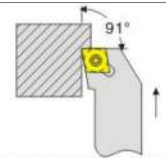
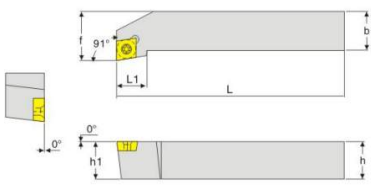
SCFCR/L





Угол в плане 91°
Обработка торцев

									
Модель	Пластина 	Размеры						Детали	
		h	b	L	L1	h1	f	 ВИНТ	 КЛЮЧ
SCFCR/L 1212H09	CC__0603__	12	12	100	16	12	16	M4X8	T15
SCFCR/L 1616H09	CC__09T3__	16	16	100	20	16	20		
SCFCR/L 2020K12		20	20	125	20	20	25		
SCFCR/L 2525M12	CC__1204__	25	25	150	25	25	32	M5X12	T20
SCFCR/L 3232P12		32	32	170	25	32	40		

Тип S

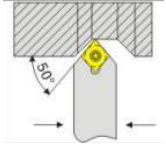
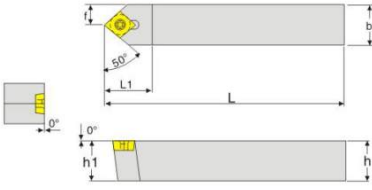
SCMCN

Угол в плане 50°
Наружное точение



									
Модель	Пластина 	Размеры						Детали	
		h	b	L	L1	h1	f	 ВИНТ	 КЛЮЧ
SCMCN 1010H06	CC__0603__	10	10	100	13	10	5	M2.5X6	T8
SCMCN 1212H09	CC__09T3__	12	12	100	18	12	6		
SCMCN 11616H09		16	16	100	18	16	8		
SCMCN 2020K09		20	20	125	18	20	10		
SCMCN 2525M09		25	25	150	18	25	12.5		
SCMCN 1616H12	CC__1204__	16	16	100	18	16	8	M5X12	T20
SCMCN 2020K12		20	20	125	23	20	10		
SCMCN 2525M12		25	25	150	23	25	12.5		

Тип S

SCMCN-100

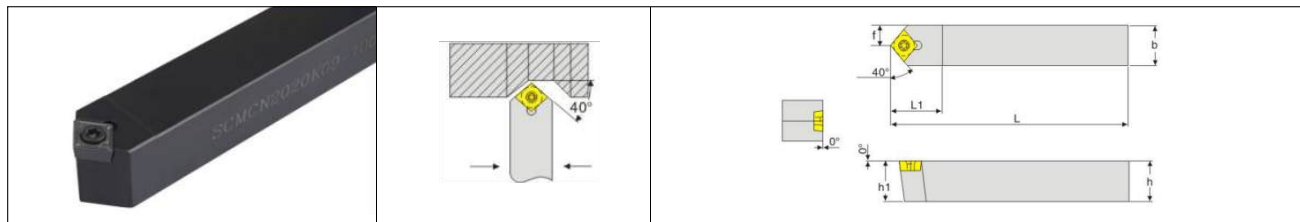
Угол в плане 40°
Наружное точение



Модель	Пластина 	Размеры						Детали	
		h	b	L	L1	h1	f	 ВИНТ	 КЛЮЧ
SCMCN 1010H06 - 100	CC__0602__	10	10	100	13	10	5	M2.5X6	T8
SCMCN 1212H09 - 100	CC__09T3__	12	12	100	18	12	6	M4X8 M4X10	T15
SCMCN 11616H09 - 100		16	16	100	18	16	8		
SCMCN 2020K09 - 100		20	20	125	18	20	10		
SCMCN 2525M09 - 100		25	25	150	18	25	12.5		
SCMCN 2020K12 - 100	CC__1204__	20	20	125	23	20	10	M5X12	T20
SCMCN 2525M12 - 100	CC__1204__	25	25	150	23	25	12.5	M5X12	T20

Тип S

SCBCR/L

Угол в плане 75°
Наружное точение

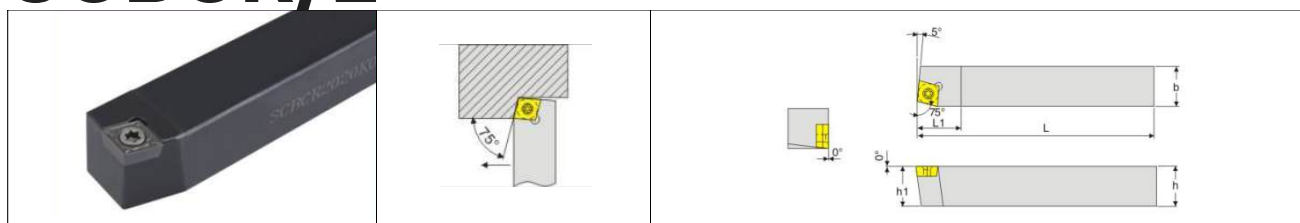





Модель	Пластина 	Размеры						Детали	
		h	b	L	L1	h1	f	 ВИНТ	 КЛЮЧ
SCBCR/L 2020K09	CC__09T3__	20	20	125	12	20	17	M4X10	T15
SCBCR/L 2525M09	CC__09T3__	25	25	150	12	25	22		
SCBCR/L 2020K12	CC__1204__	20	20	125	16	20	17	M5X12	T20
SCBCR/L 2525M12		25	25	150	16	25	22		

Тип S

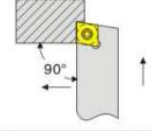
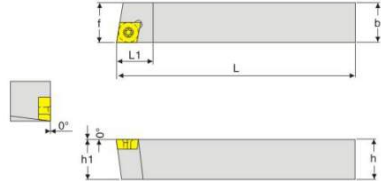
SCACR/L



Угол в плане 90°
Наружное точение, обработка торцов

									
Модель	Пластина 	Размеры						Детали	
		h	b	L	L1	h1	f	 ВИНТ	 КЛЮЧ
SCACR/L 0808H06	CC__0602__	8	8	125	10	8	8	M2.5X6	T8
SCACR/L 1010H08		10	10	125	10	10	10		
SCACR/L 1212K06		12	12	125	13	12	12		
SCACR/L 1212K09	CC__09T3__	12	12	125	13	12	12	M4X8	T15

Тип S

SDJCR/L

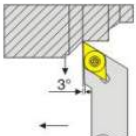
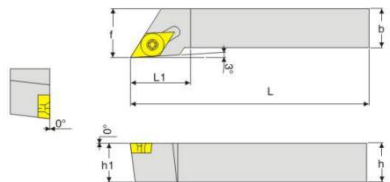
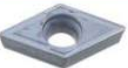
Угол в плане 93°
Наружное точение, обработка торцов

									
Модель	Пластина 	Размеры						Детали	
		h	b	L	L1	h1	f	 ВИНТ	 КЛЮЧ
SDJCR/L 1010E07	DC__T0702__	10	10	70	12	10	15	M2.5X6	T8
SDJCR/L 1212F07		12	12	80	16	12	15		
SDJCR/L 1616H07		16	16	100	20	16	18		
SDJCR/L 1212F11	DC__T11T3__	12	12	80	16	12	15	M4X8	T15
SDJCR/L 1616H11		16	16	100	20	16	24		
SDJCR/L 2020K11		20	20	125	20	20	24	M4X10	
SDJCR/L 2525M11		25	25	150	23	25	29		
SDJCR/L 3232P11		32	32	170	23	32	40		
SDJCR/L 4040R11	40	40	200	25	40	50			

Тип S

SDACR/L

Угол в плане 90°
Наружное точение

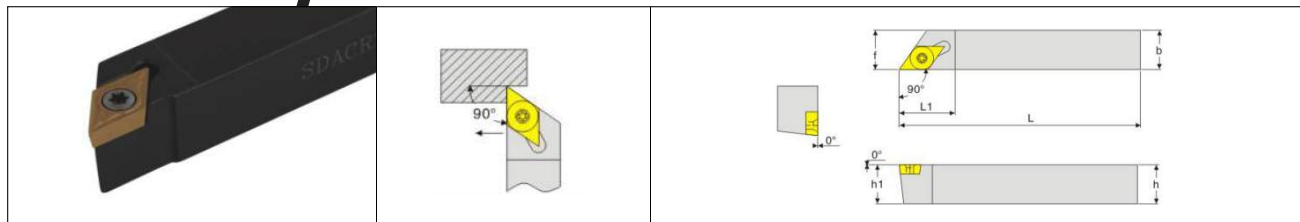

Модель	Пластина	Размеры						Детали	
		h	b	L	L1	h1	f	ВИНТ	КЛЮЧ
SDACR/L 0808K07	DC__0702__	8	8	125	15	8	8	M2.5X6	T8
SDACR/L 1010K07		10	10	125	15	10	10		
SDACR/L 1212K07		12	12	125	15	12	12		
SDACR/L 1212K11	DC__11T3__	12	12	125	22	12	12	M4X8	T15
SDACR/L 1616K11		16	16	125	22	16	16		
SDACR/L 2020K11		20	20	125	22	20	20		
SDACR/L 2525M11		25	25	150	22	25	25		

Тип S

SDFCR/L

Угол в плане 91°
Наружное точение

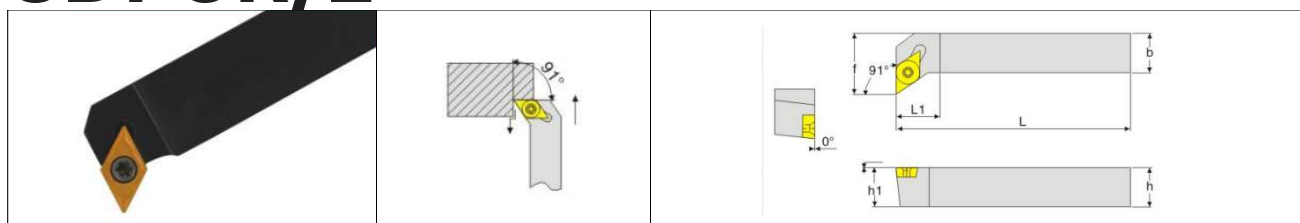





Модель	Пластина	Размеры						Детали	
		h	b	L	L1	h1	f	ВИНТ	КЛЮЧ
SDFCR/L 1212H07	DC__0702__	12	12	100	8	12	16	M2.5X6	T8
SDFCR/L 1616K11	DC__11T3__	16	16	125	14	16	20	M4X8	T15

Тип S

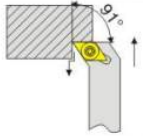
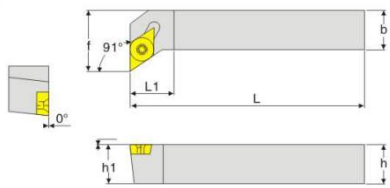
SDQCR/L





Угол в плане 107.5°
Наружное точение, профильная обработка

									
Модель	Пластина 	Размеры						Детали	
		h	b	L	L1	h1	f	 ВИНТ	 КЛЮЧ
SDQCR/L 1010H07	DC__0702__	10	10	100	12.5	10	12	M2.5X6	T8
SDQCR/L 1212H07		12	12	100	13	12	16		
SDQCR/L 1212H11	DC__11T3__	12	12	100	14	12	16	M4X8	T15
SDQCR/L 1616H11		16	16	100	14	16	20		
SDQCR/L 2020K11		20	20	125	16	20	25		
SDQCR/L 2525M11		25	25	150	22	25	32		

Тип S

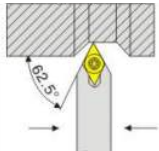
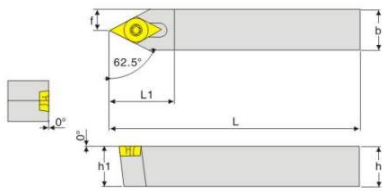
SDNCN

Угол в плане 62.5°
Наружное точение, профильная обработка





									
Модель	Пластина 	Размеры						Детали	
		h	b	L	L1	h1	f	 ВИНТ	 КЛЮЧ
SDNCN 1010E07	DC__T0702__	10	10	70	14	10	5	M2.5X6	T8
SDNCN 1212F07	DC__T11T3__	12	12	80	14	12	6	M4X8	T15
SDNCN 1212H11		12	12	100	21	12	6		
SDNCN 1616H11	DC__T11T3__	16	16	100	21	16	8	M4X10	T15
SDNCN 2020K11		20	20	125	21	20	10		

Тип S

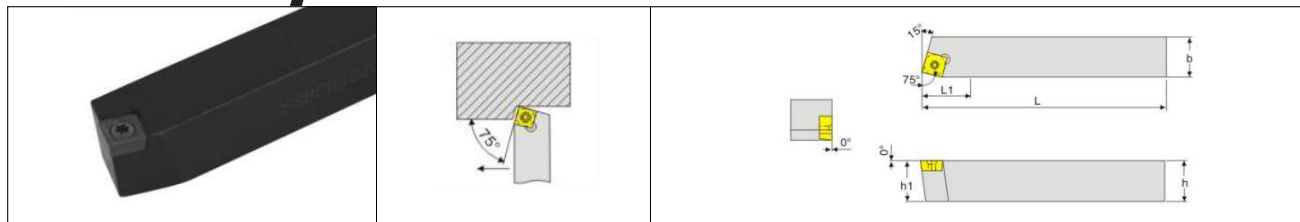
SSBCR/L

Угол в плане 75°
Наружное точение



Модель	Пластина 	Размеры						Детали	
		h	b	L	L1	h1	f	 ВИНТ	 КЛЮЧ
SSBCR/L 1212F09	SC__09T3 __	12	12	100	14	12	9.5	 M4X8	 T15
SSBCR/L 1616H09		16	16	100	14	16	13		
SSBCR/L 2020K12	SC__1204 __	20	20	125	21	20	17	 M5X12	 T20

Тип S

SSKCR/L

Угол в плане 75°
Наружное точение

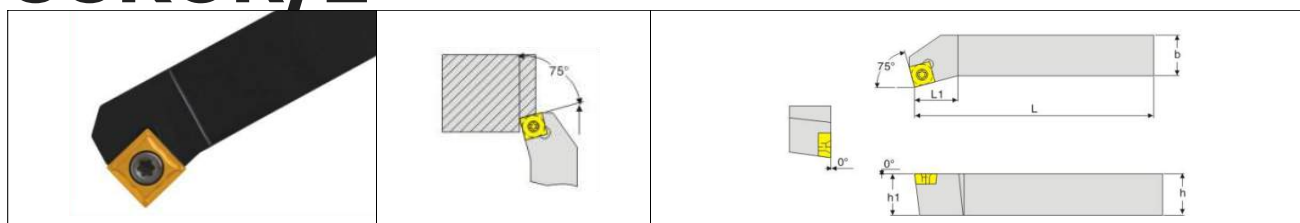





Модель	Пластина 	Размеры						Детали	
		h	b	L	L1	h1	f	 ВИНТ	 КЛЮЧ
SSKCR/L 1616H09	SC__09T3 __	16	16	100	20	16	13	 M4X10	 T15
SSKCR/L 2020K09		20	20	125	25	20	16		

Тип S

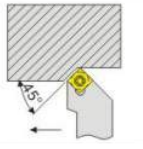
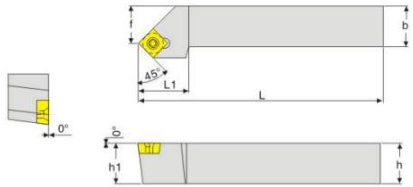
SSSCR/L





Угол в плане 45°
Наружное точение, обработка торцов и фасок

									
Модель	Пластина 	Размеры						Детали	
		h	b	L	L1	h1	f	 ВИНТ	 КЛЮЧ
SSSCR/L 1616H09	SC__T09T3__	16	16	100	17	16	20	M4X10	T15
SSSCR/L 2020K12	SC__T1204__	20	20	125	21	20	25	M5X12	T20
SSSCR/L 2525M12		25	25	150	26	25	32		

Тип S

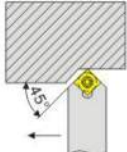
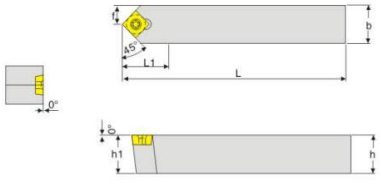
SSDCN

Угол в плане 45°
Наружное точение, профильная обработка



									
Модель	Пластина 	Размеры						Детали	
		h	b	L	L1	h1	f	 ВИНТ	 КЛЮЧ
SSDCN 1212F09	SC__T09T3__	12	12	100	16	12	6	M4X10	T15
SSDCN 1616H09		16	16	100	16	16	8		
SSDCN 2020K09		20	20	125	16	20	10		

Тип S

STGCR/L

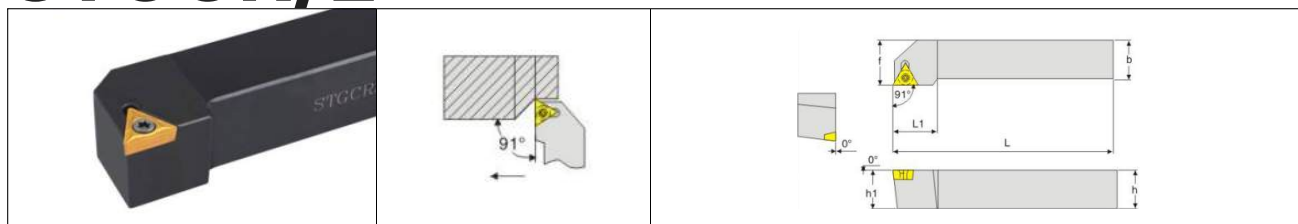
Угол в плане 91°
Наружное точение



Модель	Пластина 	Размеры						Детали	
		h	b	L	L1	h1	f	 ВИНТ	 КЛЮЧ
STGCR/L 0808D09	TC __ T0902 __	08	08	60	10	08	11	M2.2X6	T6
STGCR/L 1010E09		10	10	70	12	10	11		
STGCR/L 1212F11	TC __ T1102 __	12	12	80	16	12	16	M2.5X6	T8
STGCR/L 1616H11		16	16	100	20	16	20		
STGCR/L 2020H16	TC __ T16T3 __	20	20	125	22	20	25	M4X10	T15
STGCR/L 2525K16		25	25	150	22	25	32		
STGCR/L 3232M16		32	32	170	22	32	40		

Тип S

STFCR/L

Угол в плане 91°
Наружное точение

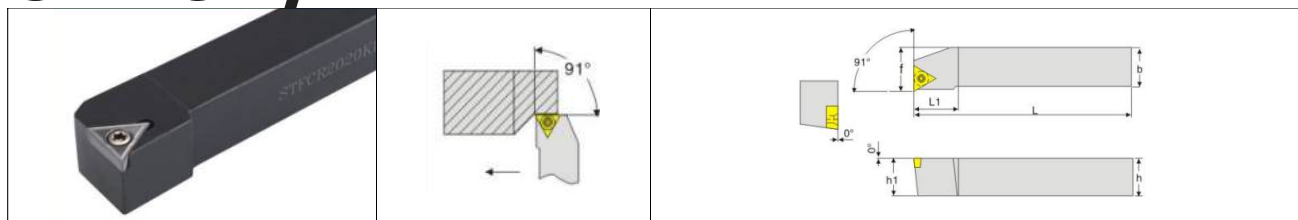



Модель	Пластина 	Размеры						Детали	
		h	b	L	L1	h1	f	 ВИНТ	 КЛЮЧ
STFCR/L 1010E09	TC __ T0902 __	10	10	70	12	10	10	M2.2X6	T6
STFCR/L 1212F11	TC __ T1102 __	12	12	80	16	12	16	M2.5X8	T8
STFCR/L 1616H11		16	16	100	16	16	20		
STFCR/L 2020H16	TC __ T16T3 __	16	16	100	16	16	20	M4X10	T15
STFCR/L 2525K16		20	20	125	22	20	25		
STFCR/L 3232M16		25	25	150	22	25	32		

Тип S

STTCR/L

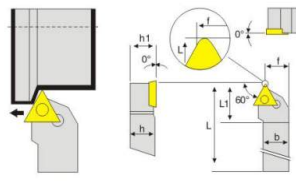



Угол в плане 60°
Наружное точение

									
Модель	Пластина 	Размеры						Детали	
		h	b	L	L1	h1	f	 ВИНТ	 КЛЮЧ
STTCR/L 1616H11	TC__T1102__	16	16	100	14	16	13	M2.5X6	T8
STTCR/L 1616K16	TC__T16T3__	16	16	100	19	16	13	M4X10	T15
STTCR/L 2020K16		20	20	125	19	20	17		

Тип S

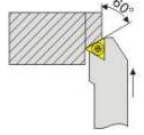
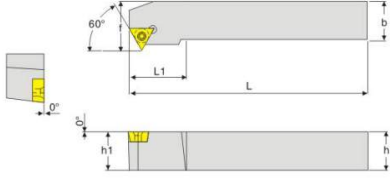
SWTCR/L





Угол в плане 60°
Наружное точение

											
Модель	Пластина 	Размеры						Детали			
		h	b	L	L1	h1	f	 ВИНТ	 КЛЮЧ		
STWCR/L 1212H11	TC__1102__	12	12	100	8	12	15.3	M2.5X6	T8		
STWCR/L 1616H11		16	16	100	8	16	19.3				
STWCR/L 2020K11		20	20	125	8	20	23.3				
STWCR/L 2525M11		25	25	150	8	25	28.3				
STWCR/L 1616H16	TC__16T3__	16	16	100	12	16	21	M4X8	T15		
STWCR/L 2020H16		20	20	125	12	20	26				
STWCR/L 2525K16		25	25	150	12	25	31				
STWCR/L 3232P16		32	32	170	12	32	38				

Тип S

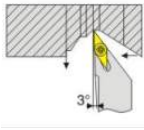
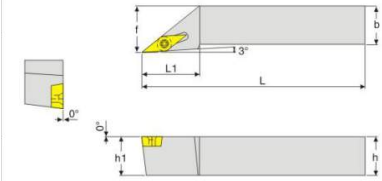
SVJ*R/L





Угол в плане 93°
Токарная и профильная обработка

									
Модель С: задний угол пластины 7° В: задний угол пластины 5°	Пластина	Размеры						Детали	
		h	b	L	L1	h1	f	 ВИНТ	 КЛЮЧ
SVJ*R/L 1616H16	VC__1604__ VB__1604__	16	16	100	32	16	20	M4X10	T15
SVJ*R/L 2020K16		20	20	125	32	20	25		
SVJ*R/L 2525M16		25	25	150	32	25	32		
SVJ*R/L 3232P16		32	32	170	40	32	40		

Тип S

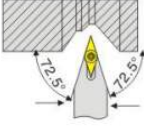
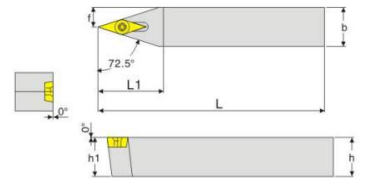
SVV*N





Угол в плане 72.5°
Токарная и профильная обработка

									
Модель С: задний угол пластины 7° В: задний угол пластины 5°	Пластина	Размеры						Детали	
		h	b	L	L1	h1	f	 ВИНТ	 КЛЮЧ
SVV*N 1616H11	VC__1103__ VB__1103__	16	16	100	24	16	8	M2.5X6	T8
SVV*N 2020K11		20	20	125	24	20	10		
SVV*N 2525M11		25	25	150	24	25	12.5		
SVV*N 1616H16	VC__1604__ VB__1604__	16	16	100	34	16	8	M4X10	T15
SVV*N 2020H16		20	20	125	34	20	10		
SVV*N 2525K16		25	25	150	34	25	12.5		
SVV*N 3232P16		32	32	170	34	32	16		

Тип S

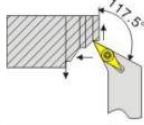
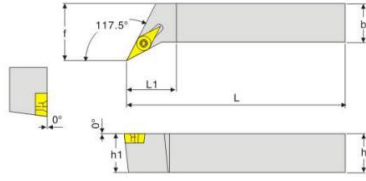
SVQ*R/L





Угол в плане 117.5°
Наружное точение

									
Модель <small>С: задний угол пластины 7° В: задний угол пластины 5°</small>	Пластина 	Размеры						Детали	
		h	b	L	L1	h1	f	 ВИНТ	 КЛЮЧ
SVQ*R/L 1616H16	VC__1604__ VB__1604__	16	16	100	35	16	20	M4X10	T15
SVQ*R/L 2020K16		20	20	125	35	20	25		
SVQ*R/L 2525M16		25	25	150	35	25	32		
SVQ*R/L 3232P16		32	32	170	35	32	40		

Тип S

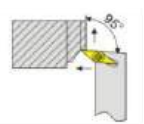
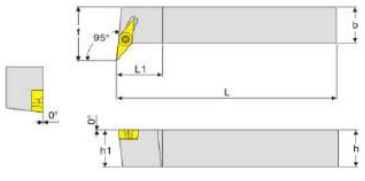
SVU*R/L

Угол в плане 95°
Наружное точение

									
Модель <small>С: задний угол пластины 7° В: задний угол пластины 5°</small>	Пластина 	Размеры						Детали	
		h	b	L	L1	h1	f	 ВИНТ	 КЛЮЧ
SVUBR/L 1616H11	VC__1103__	16	16	100	12	16	16	M2.5X6	T8
SVUCR/L 2020K11	VB__1103__	16	16	100	16	16	20		
SVUBR/L 2525M16	VC__1604__	25	25	150	16	25	32	M4X10	T15
SVUCR/L 3232P16	VB__1604__	32	32	170	16	32	40		

Тип S

SRACR/L

Токарная профильная обработка

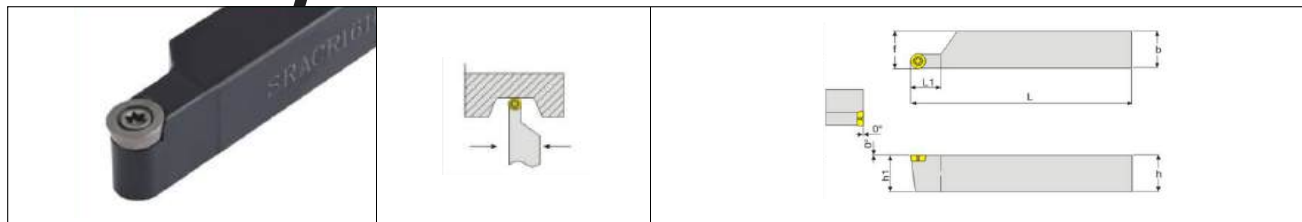

Модель	Пластина	Размеры						Детали	
		h	b	L	L1	h1	f	ВИНТ	КЛЮЧ
SRACR/L 1616H08	RC__0803__	16	16	100	16	16	16.5	M3X8	T10
SRACR/L 2020K08		20	20	125	16	20	20.5		
SRACR/L 2525M08		25	25	150	16	25	25.5		
SRACR/L 2020K10	RCGT__1003__	20	20	125	20.3	20	20.4	M4X10	T15
SRACR/L 2525M10		25	25	150	20.3	25	25.4		

Тип S

SRDCN

Токарная профильная обработка

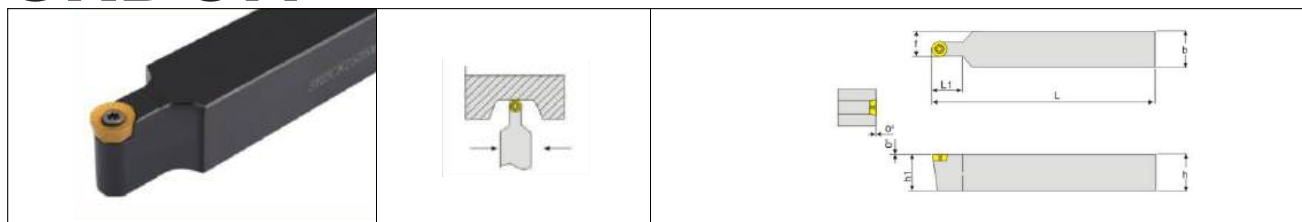





Модель	Пластина	Размеры						Детали	
		h	b	L	L1	h1	f	ВИНТ	КЛЮЧ
SRDCN 1616H08	RC__0803__	16	16	100	16	16	8	M3X8	T8
SRDCN 2020K08		20	20	125	16	20	10		
SRDCN 2525M08		25	25	150	16	25	12.5		
SRDCN 1010H10	RC__10T3__	10	10	100	20.3	10	5	M4X8	T15
SRDCN 1616H10		16	16	100	20.3	16	8		
SRDCN 2020K10		20	20	125	20.3	20	10		
SRDCN 2525M10		25	25	150	20.3	25	12.5		
SRDCN 3232P10		32	32	170	20.3	32	16		

Тип S

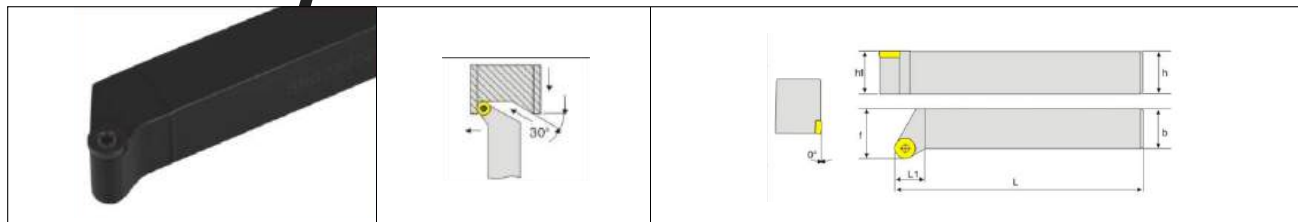
SRGCR/L

Наружное точение







Модель	Пластина 	Размеры						Детали	
		h	b	L	L1	h1	f	 ВИНТ	 КЛЮЧ
SRGCR/L 1212H05	RC__0502__	12	12	100	9.5	12	16	M2.2X4	T7
SRGCR/L 1616H05		16	16	100	9.5	16	20		
SRGCR/L 2020K05		20	20	125	11.2	20	25		
SRGCR/L 2525M05		25	25	150	14.7	25	32		
SRGCR/L 1212H06	RC__0602__	12	12	100	10	12	16	M2.5X6	T8
SRGCR/L 1616H06		16	16	100	10	16	20		
SRGCR/L 2020K06		20	20	125	12	20	25		
SRGCR/L 2525M06		25	25	150	15	25	32		
SRGCR/L 1616H08	RC__0803__	16	16	100	11	16	20	M3X8	T9
SRGCR/L 2020K08		20	20	125	12.7	20	25		
SRGCR/L 2525M08		25	25	150	16.2	25	32		

Тип S

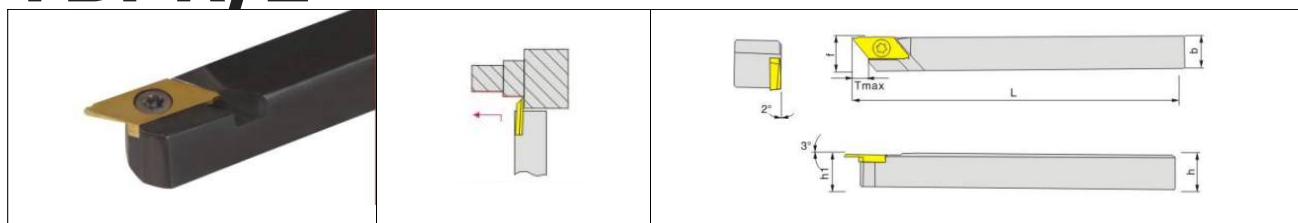
TBPR/L

Наружное точение и обработка ступеней вала







Модель	Пластина 	Размеры						Детали	
		h	b	L	L1	h1	f	 ВИНТ	 КЛЮЧ
TBPR/L 08	TBP55FR/L__	8	8	120	8	3.5	5.5	M4X10	T15
TBPR/L 10		10	10	120	10	3.5	5.5		
TBPR/L 12		12	12	120	12	3.5	5.5		
TBPR/L 16		16	16	120	16	3.5	5.5		
TBPR/L 20		20	20	120	20	3.5	5.5		

Тип S

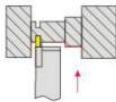
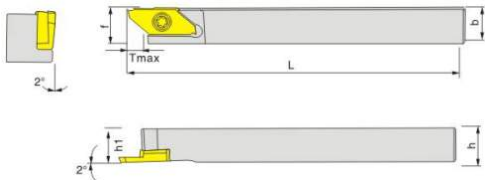
KTKFR/L





Наружное точение и обработка ступеней вала

									
Модель	Пластина 	Размеры						Детали	
		h	b	L	L1	h1	f	 ВИНТ	 КЛЮЧ
KTKFR/L 1212JX-16	TKFB16R38	12	12	120	12	12	8	M4X10	T15
KTKFR/L 1616JX-16		16	16	120	16	16	8		
KTKFR/L 2020JX-16		20	20	120	20	20	8		

Тип S

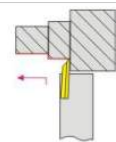
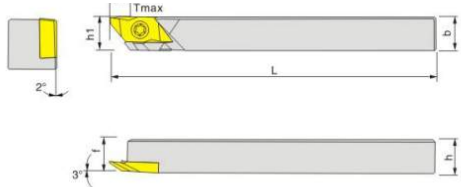
TBPAR































Наружное точение и обработка ступеней вала

									
Модель	Пластина 	Размеры						Детали	
		h	b	L	L1	h1	f	 ВИНТ	 КЛЮЧ
TBPAR 10	TBP60FR/L __	10	10	120	10	10	7.5	M4X10	T15
TBPAR 12		12	12	120	12	12	7.5		
TBPAR 16		16	16	120	16	16	7.5		
TBPAR 20		20	20	120	20	20	7.5		

Расточные державки

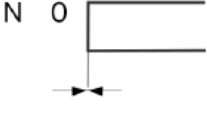
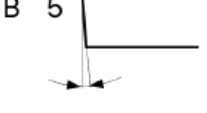
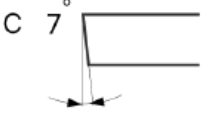
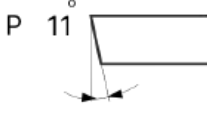
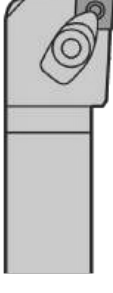
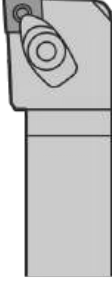
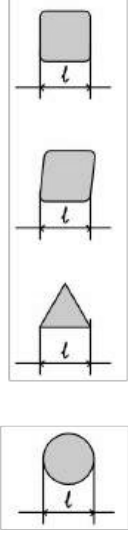

Геометрические параметры державок

S	25	R	-	M																																
<p>1 материал</p> <p>C твердый сплав</p> <p>H быстрорежущая сталь</p> <p>S инструментальная сталь</p>	<p>2 диаметр хвостовика</p>	<p>3 длина</p> <table border="1"> <thead> <tr> <th>обозначение, мм</th> <th>длина, мм</th> <th>обозначение, мм</th> <th>длина, мм</th> </tr> </thead> <tbody> <tr> <td>H</td> <td>100</td> <td>T</td> <td>300</td> </tr> <tr> <td>K</td> <td>125</td> <td>U</td> <td>350</td> </tr> <tr> <td>M</td> <td>150</td> <td>V</td> <td>400</td> </tr> <tr> <td>N</td> <td>160</td> <td>W</td> <td>450</td> </tr> <tr> <td>Q</td> <td>180</td> <td>Y</td> <td>500</td> </tr> <tr> <td>R</td> <td>200</td> <td></td> <td></td> </tr> <tr> <td>S</td> <td>250</td> <td></td> <td></td> </tr> </tbody> </table>	обозначение, мм	длина, мм	обозначение, мм	длина, мм	H	100	T	300	K	125	U	350	M	150	V	400	N	160	W	450	Q	180	Y	500	R	200			S	250				<p>4 способ зажима</p> <p>модель С-типа </p> <p>модель М-типа </p> <p>модель S-типа </p>
обозначение, мм	длина, мм	обозначение, мм	длина, мм																																	
H	100	T	300																																	
K	125	U	350																																	
M	150	V	400																																	
N	160	W	450																																	
Q	180	Y	500																																	
R	200																																			
S	250																																			
C	L	N	R	12																																
<p>5 форма пластины</p> <ul style="list-style-type: none">  Четыреугольник C - 80°  Четыреугольник D - 55°  Параллелограмм K - 55°  Круг R  Квадрат S  Треугольник T  Четыреугольник V - 35°  Ломанный треугольник 	<p>6 угол врезки</p> <ul style="list-style-type: none">  A-90°  B-75°  C-90°  D-45°  E-60°  F-91°  G-91°  G-91°  J-93°  K-75°  L-95°  N-63°  P-62.5°  Q-45°  S-45°  V-72.5°  U-93°  X-100°  Y-80°  Z-93° 	<p>7 угол зазора лезвия</p> <ul style="list-style-type: none">  N 0°  B 5°  C 7°  P 11° 	<p>8 направление</p> <p>L </p> <p>R </p>	<p>9 длина режущей кромки</p> 																																

Содержание тип М

MCLNR/L	158	MDUNR/L	163
MCKNR/L	158	MDQNR/L	163
MCWNR/L	159	MDZNR/L	164
MTJNR/L	159	MVQNR/L	164
MTFNR/L	160	MVXNR/L	165
MTWNR/L	160	MVUNR/L	165
MTUNR/L	161	MVWNR/L	166
MTQNR/L	161		
MWLNR/L	162		
MSKNR/L	162		



Тип М

MCLNR/L

Угол в плане 95°
Обработка торцов, растачивание глухих и сквозных отверстий

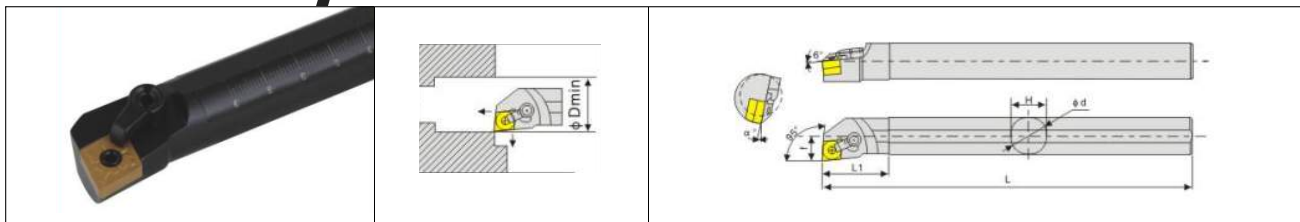

Модель	Пластина	Размеры							Детали				
		ØDmin	Ød	L	L1	H	f	a°	подкладная пластина	винт крепления пластин	прижим	винт крепления прижима	ключ
S20R-MCLNR/L 12	CN_1204_	25	20	200	45	19	13	15°	SC1204	CTM613	HL1810	ML0620	L 2.5 3.0
S25S-MCLNR/L 12		32	25	250	45	24	16.5	12°			HL1814		
S32T-MCLNR/L 12		40	32	300	50	30	22.5	17°					
S40U-MCLNR/L 12		50	40	350	55	38	26	15°					
S40U-MCLNR/L 16	CN_1606_	50	40	350	55	38	26	15°	SC1604	CTM819	HL1719	ML0825	L 4.0 5.0

Тип М

MCKNR/L

Угол в плане 75°
Растачивание сквозных отверстий

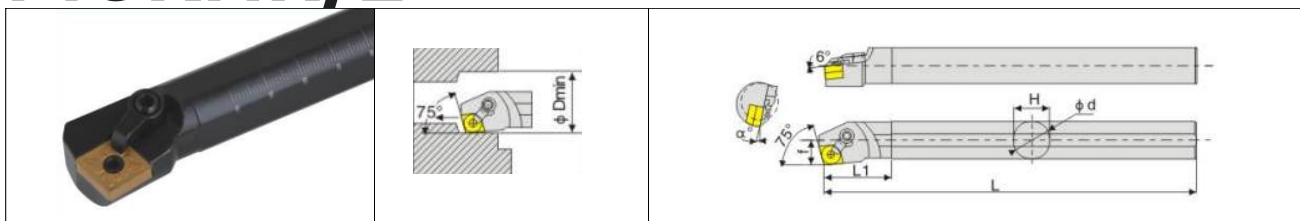

Модель	Пластина	Размеры							Детали				
		ØDmin	Ød	L	L1	H	f	a°	подкладная пластина	винт крепления пластин	прижим	винт крепления прижима	ключ
S20R-MCKNR/L 12	CN_1204_	25	20	200	45	19	14	15°	SC1204	CTM613	HL1810	ML0620	L 2.5 3.0
S25S-MCKNR/L 12		32	25	250	45	24	16	12°			HL1814		
S32T-MCKNR/L 12		40	32	300	50	30	22	17°			CTM617		
S40U-MCKNR/L 12		50	40	350	55	38	26	15°					

Тип М

MCWNR/L

Угол в плане 75°
Растачивание сквозных отверстий

Модель	Пластина 	Размеры							Детали				
		ØDmin	Ød	L	L1	H	f	a°					
S20R-MCWNR/L 12	CN_1204_	30	20	200	45	19	17	15°	SC1204	CTM613	HL1810	ML0620	L 2.5 3.0
S25S-MCWNR/L 12		35	25	250	45	24	19.5	12°					
S32T-MCWNR/L 12		42	32	300	50	30	23	17°					
S40U-MCWNR/L 12		50	40	350	55	38	27	15°					

Тип М

MTJNR/L

Угол в плане 93°
Профильная обработка, растачивание глухих отверстий

Модель	Пластина 	Размеры							Детали					
		ØDmin	Ød	L	L1	H	f	a°						
S20R-MTJNR/L 16	TN_1604_	25	20	200	40	19	13	15°	ST1603	CTM510	HL1810	ML0620	L 2.0 3.0	
S25S-MTJNR/L 16		32	25	250	45	24	16	12°						CTM513
S32T-MTJNR/L 16		41	32	300	54	30	22.5	17°						

Тип M

MTFNR/L

Угол в плане 91°
Обработка торцов, растачивание глухих отверстий

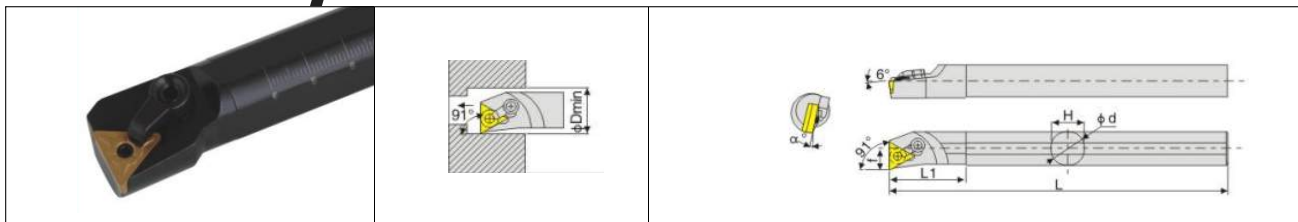

Модель	Пластина	Размеры							Детали				
		ϕD_{min}	ϕd	L	L1	H	f	α°	подкладная пластина	винт крепления пластин	прижим	винт крепления прижима	ключ
S20R-MTFNR/L 16	TN_1604_	25	20	200	40	19	13	15°	ST1603	CTM510	HL1810	ML0620	L 2.0 3.0
S25S-MTFNR/L 16		32	25	250	45	24	16.5	12°					
S32T-MTFNR/L 16		41	32	300	54	30	22.5	17°					
S40U-MTFNR/L 16		50	40	350	60	38	26.5	15°					

Тип M

MTWNR/L

Угол в плане 60°
Профильная обработка, растачивание глухих отверстий

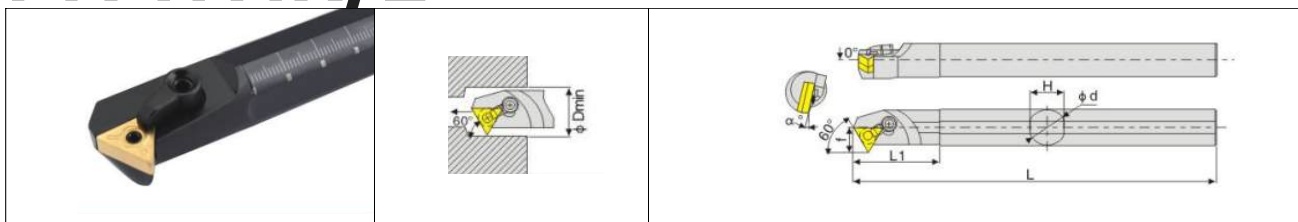

Модель	Пластина	Размеры							Детали				
		ϕD_{min}	ϕd	L	L1	H	f	α°	подкладная пластина	винт крепления пластин	прижим	винт крепления прижима	ключ
S20R-MTWNR/L 16	TN_1604_	27	20	200	40	19	14	15°	ST1603	CTM510	HL1810	ML0620	L 2.0 3.0
S25S-MTWNR/L 16		32	25	250	45	24	16.5	12°					
S32T-MTWNR/L 16		39	32	300	54	30	20	17°					

Тип М

MTUNR/L

Угол в плане 95°
Растачивание глухих и сквозных отверстий

Модель	Пластина 	Размеры							Детали									
		ØDmin	Ød	L	L1	H	f	a°										
S20R-MTUNR/L 16	TN_1604_	25	20	200	40	13	13	15°										
S25S-MTUNR/L 16		32	25	250	45	24	16.5	12°						ST1603	CTM510	HL1810	ML0620	L 2.0 3.0
S32T-MTUNR/L 16		41	32	300	54	30	22.5	17°										
S40U-MTUNR/L 16		50	40	350	60	38	26.5	15°						ST1603	CTM513	HL1814	ML0625	L 2.0 3.0

Тип М

MTQNR/L

Угол в плане 105°
Профильная обработка, растачивание глухих и сквозных отверстий

Модель	Пластина 	Размеры							Детали									
		ØDmin	Ød	L	L1	H	f	a°										
S20R-MTQNR/L 16	TN_1604_	25	20	200	40	19	12.5	15°										
S25S-MTQNR/L 16		32	25	250	45	24	16	12°						ST1603	CTM510	HL1810	ML0620	L 2.0 3.0
S32T-MTQNR/L 16		41	32	300	54	30	22.5	17°										
S40U-MTQNR/L 16		50	40	350	60	38	26.5	15°						ST1603	CTM513	HL1814	ML0625	L 2.0 3.0

Тип M

MWLNLR/L

Угол в плане 95°
Обработка торцов, растачивание глухих и сквозных отверстий

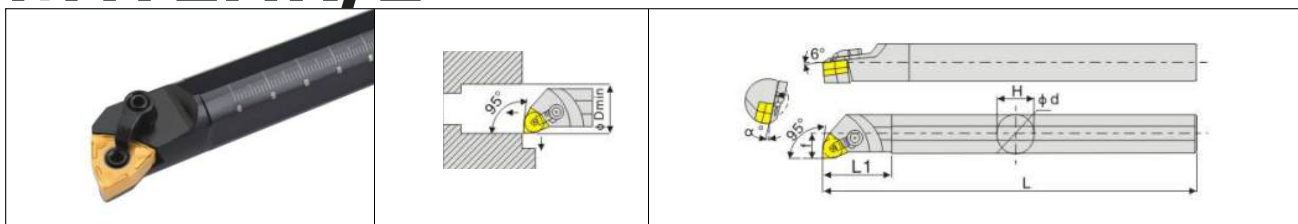

Модель	Пластина	Размеры							Детали				
		ØDmin	Ød	L	L1	H	f	a°	подкладная пластина	винт крепления пластин	прижим	винт крепления прижима	ключ
S16Q-MWLNLR/L 06	WN_0604_	22	16	180	35	15	11.0	18°	SW0603	CTM510	HL1510	ML0520	L 2.0 3.0
S20R-MWLNLR/L 06		25	20	200	40	19	13.0	15°					
S25S-MWLNLR/L 06		32	25	250	36	23	17.0	18°					
S32T-MWLNLR/L 06		40	32	300	50	30	22.0	15°					
S40U-MWLNLR/L 06		50	40	350	60	37	27.0	15°					
S25S-MWLNLR/L 08	WN_0804_	32	25	250	36	23	17.0	12°	SW0804	CTM617	HL1814	ML0625	L 3.0 4.0
S32T-MWLNLR/L 08		40	32	300	50	30	22.0	17°					
S40U-MWLNLR/L 08		50	40	350	60	37	27.0	15°					

Тип M

MSKNR/L

Угол в плане 75°
Обработка торцов, растачивание сквозных отверстий

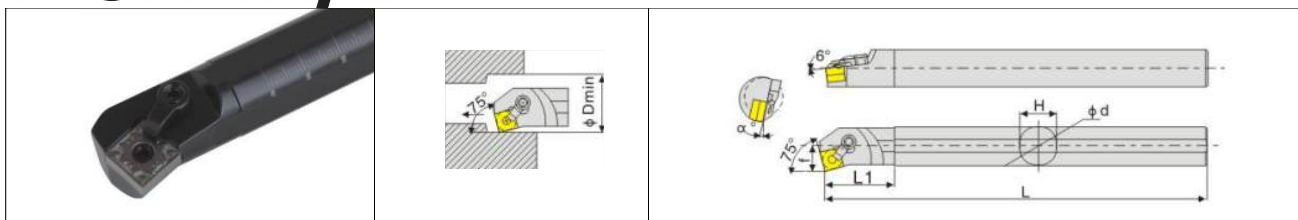

Модель	Пластина	Размеры							Детали				
		ØDmin	Ød	L	L1	H	f	a°	подкладная пластина	винт крепления пластин	прижим	винт крепления прижима	ключ
S20R-MSKNR/L 12	SN_1204_	32	20	200	40	19	13.0	15°	SC1204	CTM613	HL1810	ML0625	L 2.5 3.0
S25S-MSKNR/L 12		32	25	250	45	24	17.0	12°					
S32T-MSKNR/L 12		40	32	300	50	30	22.0	17°					
S40U-MSKNR/L 12		50	40	350	55	38	27.0	15°					
S50V-MSKNR/L 12		60	50	400	65	48	30.0	12°					

Тип М

MDUNR/L

Угол в плане 95°
Профильная обработка, растачивание глухих и сквозных отверстий

Модель	Пластина	Размеры							Детали				
		ØDmin	Ød	L	L1	H	f	α°					
S25S-MDUNR/L 15	DN_1504_	32	25	250	45	24	16	12°	SD1503	CTM619	HL2114	ML0625	L 2.5 3.0
S32T-MDUNR/L 15		40	32	300	50	30	21	17°					
S40U-MDUNR/L 15		50	40	350	60	38	26	15°					

Тип М

MDQNR/L







Угол в плане 107.5°
Токарная обработка канавок

Модель	Пластина	Размеры							Детали				
		ØDmin	Ød	L	L1	H	f	α°					
S25S-MDQNR/L 15	DN_1504_	32	25	250	45	24	17	12°	MD1506	CTM613	HL2114	ML0625	L 2.5 3.0
S32T-MDQNR/L 15		40	32	300	50	30	22.5	17°					
S40U-MDQNR/L 15		50	40	300	60	38	27	15°					

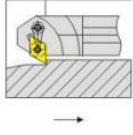
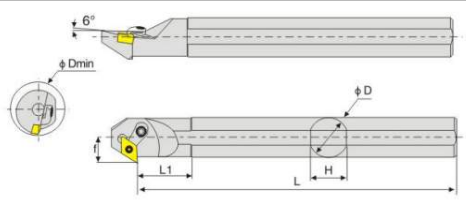
Тип М

MDZNR/L







Угол в плане 93°
Профильная обработка, растачивание глухих отверстий

													
Модель	Пластина	Размеры							Детали				
		ØDmin	Ød	L	L1	H	f	a°					
S32T-MDZNR/L 15		40	32	300	50	30	23	17°	SD1506	CTM619	HL2114	ML0625	L 2.5 3.0
S40U-MDZNR/L 15	DN_1504_	50	40	350	55	38	27	15°					

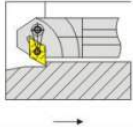
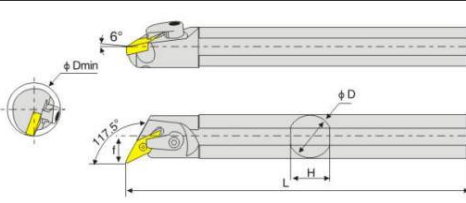
Тип М

MVQNR/L

Угол в плане 117.5°
Профильная обработка, обработка глухих и сквозных отверстий

													
Модель	Пластина	Размеры							Детали				
		ØDmin	Ød	L	L1	H	f	a°					
S25S-MVQNR/L 16		32	25	250	45	24	17	12°					
S32T-MVQNR/L 16	VN_1604_	42	32	300	50	30	23	17°	SV1603	CTM513	HL2114	ML0625	L 2.0 3.0
S40U-MVQNR/L 16		50	40	350	55	38	27	15°					

Тип М

MVXNR/L

Угол в плане 96°
Профильная токарная обработка

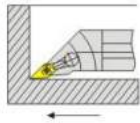
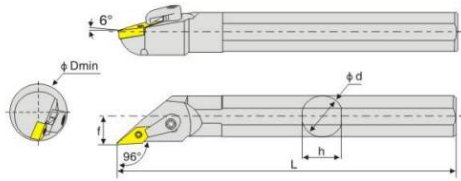
													
Модель	Пластина	Размеры							Детали				
		ØDmin	Ød	L	L1	H	f	a°	подкладная пластина	винт крепления пластин	прижим	винт крепления прижима	ключ
S20R-MVXNR/L	VN_1604_	27	20	200	40	19	14	15°	SV1603	CTM510	HL2114	ML0625	L 2.0 3.0
S25S-MVXNR/L		32	25	250	45	24	17	12°					
S32T-MVXNR/L		42	32	300	50	30	23	17°					
S40U-MVXNR/L		50	40	350	55	38	27	15°					

Тип М

MVUNR/L

Угол в плане 93°
Профильная токарная обработка

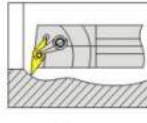
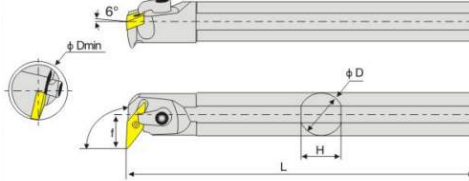
													
Модель	Пластина	Размеры							Детали				
		ØDmin	Ød	L	L1	H	f	a°	подкладная пластина	винт крепления пластин	прижим	винт крепления прижима	ключ
S25S-MVUNR/L 16	VN_1604_	36	25	250	45	24	20	12°	SV1603	CTM510	HL2114	ML0625	L 2.0 3.0
S32T-MVUNR/L 16		42	32	300	50	30	22	17°					
S40U-MVUNR/L 16		50	40	350	55	38	26	15°					

MVWNR/L

Угол в плане 72.5°
Профильная токарная обработка

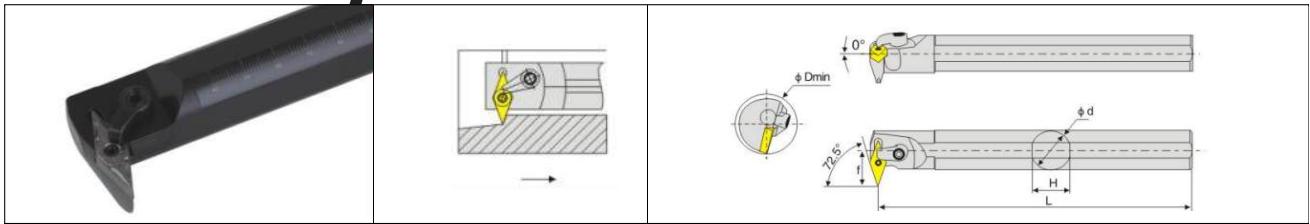

Модель	Пластина	Размеры							Детали				
		ϕD_{min}	ϕd	L	L1	H	f	a°	подкладная пластина	винт крепления пластин	прижим	винт крепления прижима	ключ
S25S-MVWNR/L 16		40	25	250	45	24	26	12°			HL1810		
S32T-MVWNR/L 16	VN_1604_	45	32	300	50	30	30	17°	SV1603	CTM513	HL1814	ML0625	L 2.0 3.0

Содержание тип S,JS



SCLCR/L	168	SWLCR/L	179
SCLCR/L 95	169	SDXCR/L	180
SCKCR/L	169	STU*R/L	180
SCKCR/L 75	170	SWUBR/L	181
SCZCR/L	170	SCLCR/L	181
SDUCR/L	171	STU**R/L	182
SDQCR/L	171	STFCR/L	182
SDZCR/L	172	SWUBR06	183
SDWCR/L	172		
SDXCR/L	173		
SDWCR/L	173		
STFCR/L	174		
STUCR/L	175		
SSSCR/L	176		
SSKCR/L	176		
SVQ*R/L	177		
SVU*R/L	177		
SVX*R/L	178		
SVZ*R/L	178		
SVW*R/L	179		

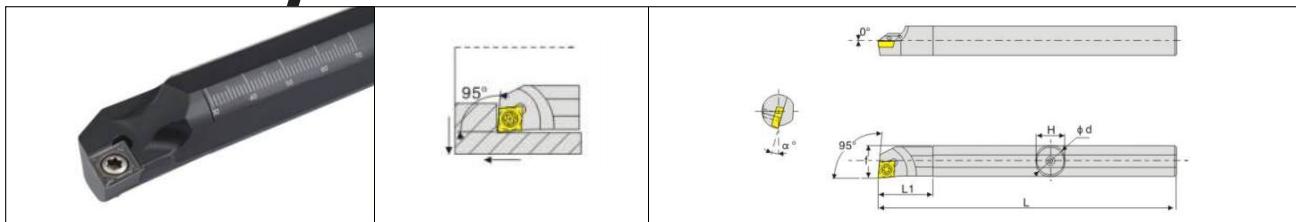

SCLCR/L

Угол в плане 95°
Обработка торцов, растачивание глухих и сквозных отверстий







Модель	Пластина 	Размеры							Детали	
		ØDmin	ØD	f	L	L1	H	α°	 ВИНТ	 КЛЮЧ
S08K-SCLCR/L11	CC__0602__	10	8	5	125	14	7	-15°	M2.5X6	T8
S10K-SCLCR/L11		12	10	6	125	14	9	-13°		
S10K-SCLCR/L11		12	10	6	125	14	9	-13°		
S12M-SCLCR/L11		16	12	9	150	25	11	-10°		
S16Q-SCLCR/L11		20	16	11	180	32	15	-8°		
S12M-SCLCR/L11	CC__09T3__	16	12	9	150	25	11	-12°	M4X8	T15
S16Q-SCLCR/L11		20	16	11	180	32.5	15	-8°		
S20R-SCLCR/L11		25	20	13	200	38	23	-6°		
S25S-SCLCR/L11		32	25	17	250	45	23	-6°		
S25S-SCLCR/L11	CC__1204__	32	25	17	250	45	23	-6°	M5X12	T20
S32T-SCLCR/L11		40	32	22	300	50	30	-10°		
S40U-SCLCR/L11		50	40	27	350	60	37	-8°		
H08K-SCLCR/L11	CC__0602__	10	8	5	125	14	7	-15°	M2.5X6	e8
H10K-SCLCR/L11		12	10	6	125	14	9	-13°		
H10K-SCLCR/L11		12	10	6	125	14	9	-13°		
H12M-SCLCR/L11		16	12	9	150	25	11	-10°		
H16Q-SCLCR/L11		20	16	11	180	32	15	-8°		

Тип S

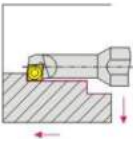
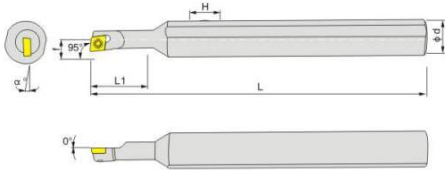
SCLCR/L





Угол в плане 95°
Токарная обработка канавок

											
Модель	Пластина 	Размеры							Детали		
		ØDmin	ØD	f	L	L1	H	α°	 ВИНТ	 КЛЮЧ	
S07M-SCLCR/L06-A16	CC__0602__	10	16	4.9	150	150	15	15°	M2.5X5	T8	
S08M-SCLCR/L06-A16		11	16	5.5	150	150	15	13°			
S10M-SCLCR/L06-A16		12	16	6	150	150	15	12°			
S12M-SCLCR/L06-A16		14	12	7	150	150	15	10°	M2.5X6		

Тип S

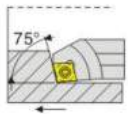
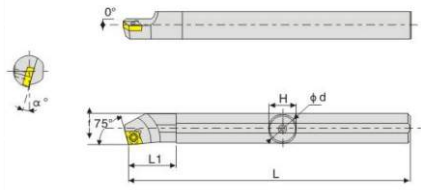
SCKCR/L





Угол в плане 75°
Растачивание сквозных отверстий

											
Модель	Пластина 	Размеры							Детали		
		ØDmin	ØD	f	L	L1	H	α°	 ВИНТ	 КЛЮЧ	
S08K-SCKCR/L06	CC__0702__	10.5	8	5.5	125	20	7	13°	M2.5X6	T8	
S10K-SCKCR/L06		13.5	10	6	125	22	9	12°			
S12M-SCKCR/L06		16	12	7	150	23	11	10°			
S12M-SCKCR/L09	CC__09T3__	16	12	8	150	30	11	12°	M4X8	T15	
S14N-SCKCR/L09		17	14	8	160	30	13	10°			
S16Q-SCKCR/L09		20	16	9.5	180	30	15	10°			
S20R-SCKCR/L09		25	20	11.5	200	35	19	8°			
S25S-SCKCR/L09		31	25	14	250	40	24	8°			

Тип S

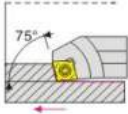
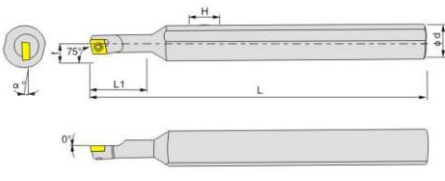
SCKCR/L





Угол в плане 75°
Токарная обработка

										
Модель	Пластина 	Размеры							Детали	
		ØDmin	ØD	f	L	L1	H	α°	 ВИНТ	 КЛЮЧ
S07M-SCKCR/L06-A16	CC__0602__	10	16	4.9	150	150	15	15°	M2.5X5	T8
S08M-SCKCR/L06-A16		11	16	5.5	150	150	15	13°		
S10M-SCKCR/L06-A16		12	16	6	150	150	15	12°		
S12M-SCKCR/L06-A16		14	12	7	150	150	15	10°	M2.5X6	

Тип S

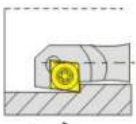
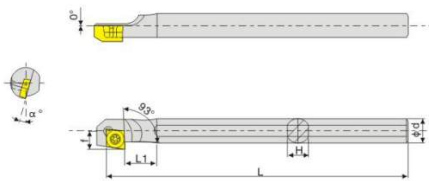
SCZCR/L

Угол в плане 93°
Растачивание сквозных отверстий

										
Модель	Пластина 	Размеры							Детали	
		ØDmin	ØD	f	L	L1	H	α°	 ВИНТ	 КЛЮЧ
S08K-SCZCR/L06	CC__0602__	12.5	8	6.5	125	25	7	13°	M2.5X6	T8
S10K-SCZCR/L06		14	10	7.5	125	27	9	12°		
S12M-SCZCR/L06		16	12	8.5	150	30	11	10°		
S16Q-SCZCR/L06		20	16	10.5	180	35	15	8°	M4X8	
S20R-SCZCR/L09		25	20	13.5	200	40	19	8°		
S25S-SCZCR/L09		32	25	16	250	42	24	6°		

Тип S

SDUCR/L

Угол в плане 93°
Обработка торцов, растачивание глухих и сквозных отверстий

Модель	Пластина 	Размеры							Детали	
		ØDmin	ØD	f	L	L1	H	α°	 ВИНТ	 КЛЮЧ
S10K-SDUCR/L07	DC__0702__	15	10	8	125	25	9	10°	M2.5X6	T8
S12M-SDUCR/L07		17	12	9	150	28	11	8°		
S16Q-SDUCR/L07		22	16	11	180	30	15	6°		
S16Q-SDUCR/L09	DC__11T3__	25	20	13	180	40	19	6°	M4X8	T15
S20R-SDUCR/L09		32	25	16	200	40	24	4°		
S25S-SDUCR/L09		39	32	20	250	45	30	4°		
S32T-SDUCR/L09		50	40	24	300	50	38	2°		
H10K-SDUCR/L07	DC__0702__	15	10	8	125	25	9	10°	M2.5X6	T8
H12M-SDUCR/L07		17	12	9	150	28	11	8°		
H16Q-SDUCR/L07		22	16	11	180	30	15	6°		

Тип S

SDQCR/L

Угол в плане 107.5°
Обработка торцов, растачивание глухих и сквозных отверстий



Модель	Пластина 	Размеры							Детали	
		ØDmin	ØD	f	L	L1	H	α°	 ВИНТ	 КЛЮЧ
S10K-SDQCR/L07	DC__0702__	13	10	7	125	23	9	10°	M2.5X6	T8
S12M-SDQCR/L07		16	12	9	150	30	11	8°		
S16Q-SDQCR/L07		20	16	10.5	180	30	15	6°		
S20R-SDQCR/L11	DC__11T3__	25	20	13	200	39	19	6°	M4X8	T15
S25S-SDQCR/L11		32	25	16	250	40	24	4°		
S32T-SDQCR/L11		39	32	20	300	43	30	4°		
H10K-SDQCR/L07	DC__0702__	13	10	7	125	23	9	10°	M2.5X6	T8
H12M-SDQCR/L07		16	12	9	150	30	11	8°		
H16Q-SDQCR/L07		20	16	10.5	180	30	15	6°		

Тип S

SDZCR/L

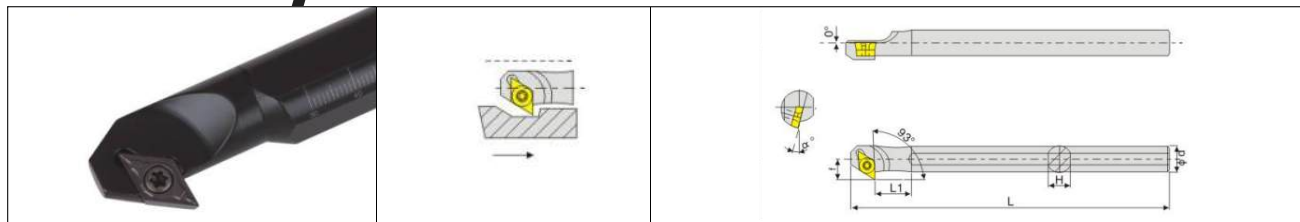
Угол в плане 93°
Профильная обработка, растачивание сквозных отверстий



Модель	Пластина 	Размеры							Детали	
		ØDmin	ØD	f	L	L1	H	α°	 ВИНТ	 КЛЮЧ
S10K-SDZCR/L07	DC __ 0702 __	16	10	8.5	125	28	9	12°	M2.5X6	T8
S12M-SDZCR/L07		18	12	9.5	150	30	11	10°		
S16Q-SDZCR/L07		24	16	11.5	180	30	15	8°		
S20R-SDZCR/L11	DC __ 11T3 __	28	20	14.5	200	40	19	8°	M4X10	T15
S25S-SDZCR/L11		34	25	17	250	45	24	6°		
S32T-SDZCR/L11		38	32	20.5	300	50	30	4°		

Тип S

SDWCR/L

Угол в плане 62.5°
Профильная обработка, растачивание сквозных отверстий

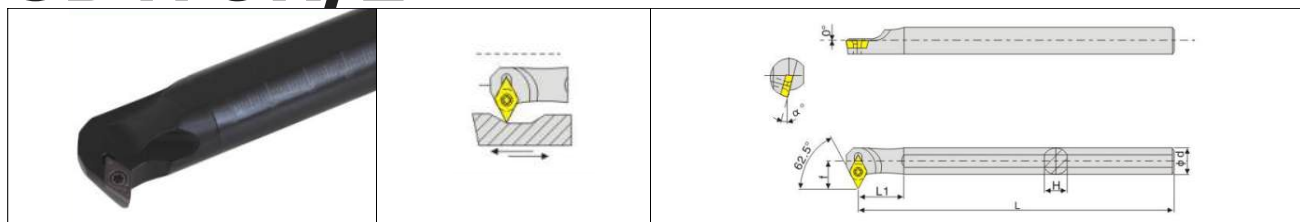





Модель	Пластина 	Размеры							Детали	
		ØDmin	ØD	f	L	L1	H	α°	 ВИНТ	 КЛЮЧ
S12M-SDWCR/L07	DC __ 0702 __	19	12	10.5	150	28	11	10°	M2.5X6	T8
S16Q-SDWCR/L07		23	16	12.5	180	30	15	8°		
S20R-SDWCR/L07		27	20	14.5	200	30	19	6°		
S20R-SDWCR/L11	DC __ 11T3 __	25.5	20	14.5	200	40	19	6°	M4X8	T15
S25S-SDWCR/L11		32	25	17	250	45	24	4°		
S32T-SDWCR/L11		40	32	20.5	300	50	30	2°		

Тип S

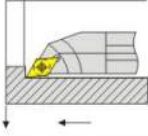
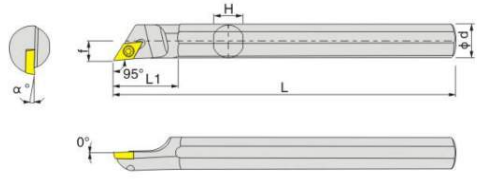
SDXCR/L





Угол в плане 95°
Токарная обработка канавок

										
Модель	Пластина 	Размеры							Детали	
		ØDmin	ØD	f	L	L1	H	α°	 ВИНТ	 КЛЮЧ
S08K-SDXCR/L07	DC__0702__	10	8	5.5	125	20	20	12°	M2.5X6	T8
S10K-SDXCR/L07		13	10	7	125	25	25	10°		
S12M-SDXCR/L07		16	12	8.5	150	30	30	8°		
S16Q-SDXCR/L07		20	16	11	180	30	30	6°		
S20R-SDXCR/L11	DC__11T3__	25	20	13	200	40	40	6°	M4X10	T15
S25S-SDXCR/L11		32	25	17	250	40	40	4°		

Тип S

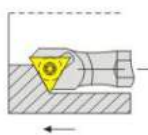
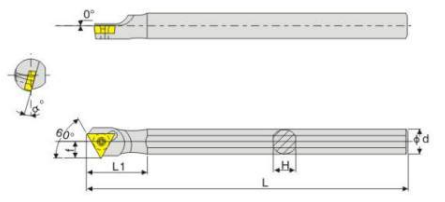
STWCR/L



Угол в плане 60°
Профильная обработка, растачивание сквозных и глухих отверстий

										
Модель	Пластина 	Размеры							Детали	
		ØDmin	ØD	f	L	L1	H	α°	 ВИНТ	 КЛЮЧ
S08K-STWCR/L09	TC__1102__	11	8	5.5	125	25	7	12°	M2.2X5	T7
S10K-STWCR/L11		14	10	7	125	25	9	10°		
S12M-STWCR/L11		16	12	9	150	30	11	8°		
S16Q-STWCR/L11		20	16	11	180	30	15	6°		
S20R-STWCR/L11	TC__16T3__	25	20	13	200	35	19	4°	M4X10	T15
S25S-STWCR/L16		32	25	17	250	45	24	6°		

STFCR/L

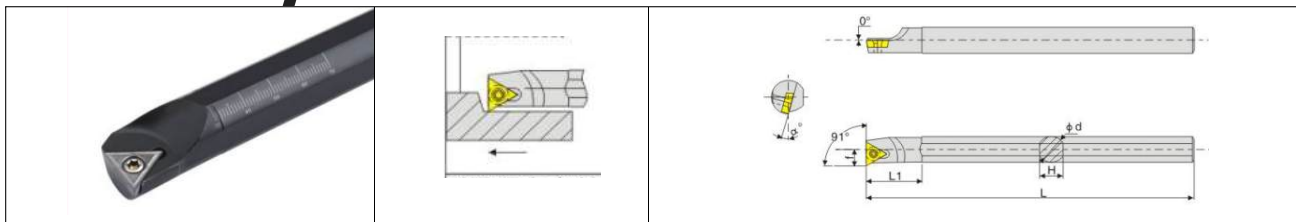
Угол в плане 91°
Обработка торцов, растачивание сквозных и глухих отверстий





Модель	Пластина 	Размеры							Детали	
		ØDmin	ØD	f	L	L1	H	α°	 ВИНТ	 КЛЮЧ
S08K-STFCR/L09	TC__0902__	11	8	5	125	23	7	15°	M2.2X5	T7
S10K-STFCR/L09		13.5	10	6	125	24	9	13°		
S12M-STFCR/L09		16	10	6	150	24	9	12°		
S10K-STFCR/L11	TC__1102__	13.5	12	7	125	27	11	10°	M2.5X6	T8
S12M-STFCR/L11		20	16	9	150	30	15	8°		
S16Q-STFCR/L11		25	20	11	180	35	19	6°		
S20R-STFCR/L11		31	25	13.5	200	40	24	4°		
S20R-STFCR/L16	TC__1102__	25	20	11	200	40	19	8°	M4X8	T15
S25S-STFCR/L16		31	25	14	250	40	24	6°		
S32T-STFCR/L16		39	32	17.5	300	45	30	4°		
H08K-STFCR/L09	TC__0902__	11	8	5	125	23	7	15°	M2.2X5	T7
H10K-STFCR/L09		13.5	10	6	125	24	9	13°		
H12M-STFCR/L09		16	10	6	150	24	9	12°		
H10K-STFCR/L11	TC__1102__	13.5	12	7	125	27	11	10°	M2.5X6	T8
H12M-STFCR/L11		20	16	9	150	30	15	8°		
H16Q-STFCR/L11		25	20	11	180	35	19	6°		

STUCR/L

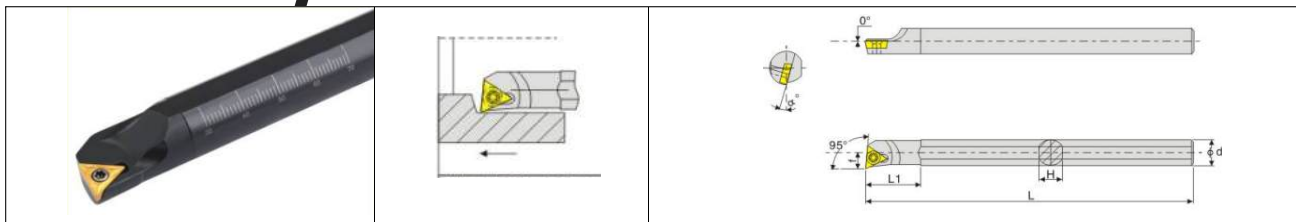
Угол в плане 95°
Обработка торцов, растачивание сквозных и глухих отверстий



Модель	Пластина 	Размеры							Детали	
		ØDmin	ØD	f	L	L1	H	α°	 ВИНТ	 КЛЮЧ
S08K-STUCR/L09	TC__0902__	10.5	8	5	125	23	7	15°	M2.2X5	T7
S10K-STUCR/L09		13.5	10	6	125	24	9	13°		
S10K-STUCR/L11	TC__1102__	13.5	10	6	125	24	9	12°	M2.5X6	T8
S12M-STUCR/L11		16	12	7	150	27	11	10°		
S16Q-STUCR/L11		20	16	9	180	30	15	8°		
S20R-STUCR/L11		25	20	11	200	35	19	6°		
S25S-STUCR/L11		31	25	13.5	250	40	24	4°		
S20R-STUCR/L16	TC__16T3__	25	20	11.5	200	40	19	8°	M4X10	T15
S25S-STUCR/L16		31	25	14	300	40	24	6°		
S32T-STUCR/L16		39	32	17.5	350	45	30	4°		
H08K-STUCR/L09	TC__0902__	10.5	8	5	125	23	7	15°	M2.2X5	T7
H10K-STUCR/L09		13.5	10	6	125	24	9	13°		
H10K-STUCR/L11	TC__1102__	13.5	10	6	125	24	9	12°	M2.5X6	T8
H12M-STUCR/L11		16	12	7	150	27	11	10°		
H16Q-STUCR/L11		20	16	9	180	30	15	8°		

Тип S

SSSCR/L

Угол в плане 45°
Растачивание сквозных отверстий, обработка фасок

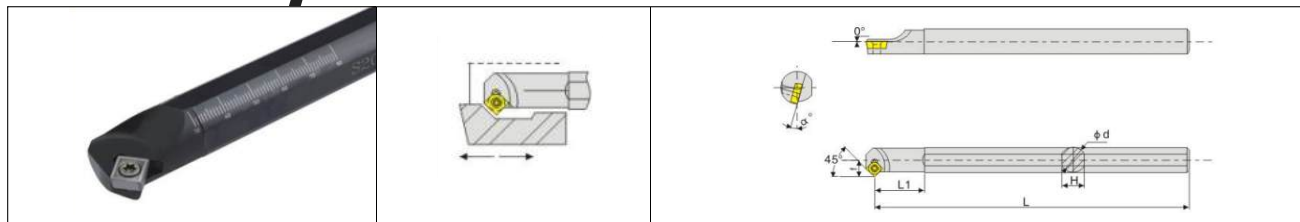

Модель	Пластина 	Размеры							Детали	
		ϕD_{min}	ϕD	f	L	L1	H	α°	 ВИНТ	 КЛЮЧ
S12M-SSSCR/L09	SC__09T3__	16	12	8.5	150	30	11	12°	M4X8	T15
S16Q-SSSCR/L09		22	16	11.5	180	35	15	10°		
S20R-SSSCR/L09		26	20	13.5	200	40	19	8°	M4X10	
S25S-SSSCR/L09		31	25	16	250	40	24	6°		
S32T-SSSCR/L09		38	32	19.5	300	45	30	4°		

Тип S

SSKCR/L

Угол в плане 75°
Растачивание сквозных отверстий, обработка торцов

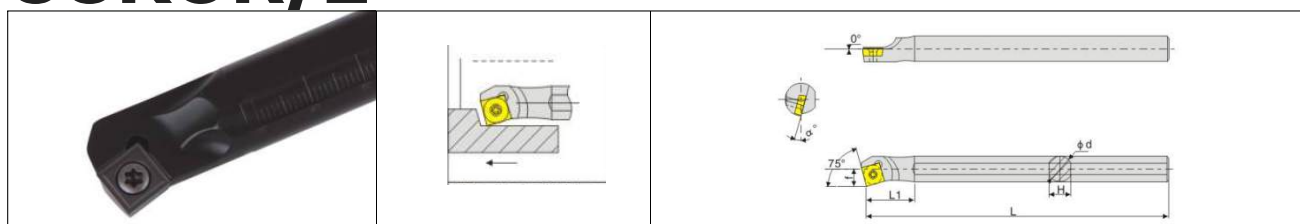





Модель	Пластина 	Размеры							Детали	
		ϕD_{min}	ϕD	f	L	L1	H	α°	 ВИНТ	 КЛЮЧ
S12M-SSKCR/L09	SC__09T3__	18	12	8.5	150	30	11	12°	M4X8	T15
S16Q-SSKCR/L09		20	16	10.5	180	30	15	10°		
S20R-SSKCR/L09		24	20	12.5	200	40	19	8°	M4X10	
S25S-SSKCR/L09		31	25	15	250	40	24	6°		

Тип S

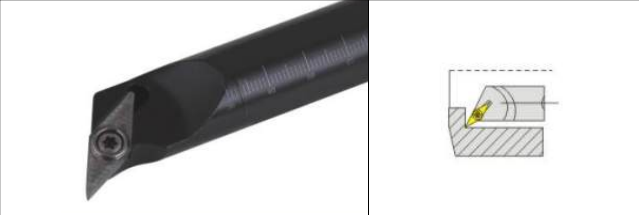
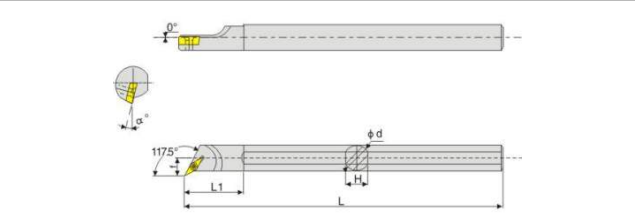
SVQ*R/L





Угол в плане 117.5°
Профильная обработка, обработка поперечных канавок

											
Модель <small>С: задний угол пластины 7° В: задний угол пластины 5°</small>	Пластина 	Размеры								Детали	
		ØDmin	ØD	f	L	L1	H	a° B C	 ВИНТ	 КЛЮЧ	
S16Q-SVQ*R/L11	VC__1103__	22	16	11.5	180	35	15	10° 8°	M2.5X6	T8	
S20R-SVQ*R/L11	VB__1103__	27	20	14	200	39	19	8° 6°			
S20R-SVQ*R/L16	VC__1604__ VB__1604__	27	20	14	200	50	19	10° 8°	M4X10	T15	
S25S-SVQ*R/L16		32	25	16.5	250	50	24	8° 6°			
S32T-SVQ*R/L16		41	32	22.5	300	55	30	10° 8°			
S40U-SVQ*R/L16		50	40	27	350	55	38	8° 6°			

Тип S

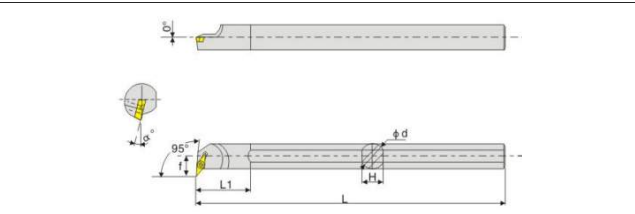
SVU*R/L

Угол в плане 95°
Профильная обработка

											
Модель <small>С: задний угол пластины 7° В: задний угол пластины 5°</small>	Пластина 	Размеры								Детали	
		ØDmin	ØD	f	L	L1	H	a° B C	 ВИНТ	 КЛЮЧ	
S16Q-SVU*R/L11	VC__1103__	22	16	11.5	180	30	15	10° 8°	M2.5X6	T15	
S20R-SVU*R/L11	VB__1103__	27	20	14	200	32	19	8° 6°			
S20R-SVU*R/L16	VC__1604__ VB__1604__	31	20	19	200	50	19	10° 8°	M4X10	T15	
S25S-SVU*R/L16		35	25	20	250	50	24	8° 6°			
S32T-SVU*R/L16		42	32	22.5	300	50	30	10° 8°			
S40U-SVU*R/L16		51	40	27	350	55	38	8° 6°			

Тип S

SVX*R/L

Угол в плане 96°
Профильная обработка

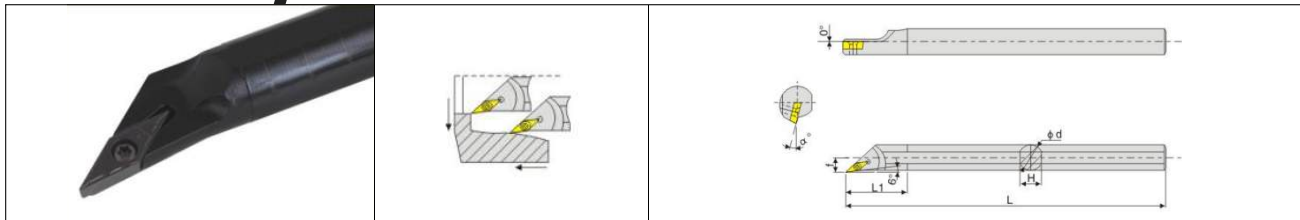

Модель <small>С: задний угол пластины 7° В: задний угол пластины 5°</small>	Пластина 	Размеры								Детали	
		ØDmin	ØD	f	L	L1	H	a° В С		 ВИНТ	 КЛЮЧ
S16Q-SVX*R/L11	VC__1103__	22	16	11	180	40	15	10°	8°	M2.5X8	T8
S20R-SVX*R/L11	VB__1103__	27	20	13.5	200	45	19	8°	6°		
S20R-SVX*R/L16	VC__1604__ VB__1604__	27	20	13.5	200	50	19	10°	8°	M4X10	T15
S25S-SVX*R/L16		32	25	16	250	50	24	8°	6°		
S32T-SVX*R/L16		40	32	19.5	300	60	30	10°	8°		
S40U-SVX*R/L16		50	40	23.5	350	65	38	8°	6°		

Тип S

SVZ*R/L

Угол в плане 93°
Профильная обработка и растачивание глухих отверстий

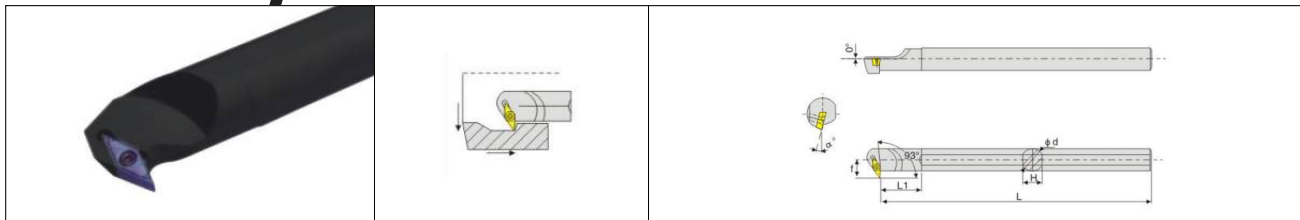

Модель <small>С: задний угол пластины 7° В: задний угол пластины 5°</small>	Пластина 	Размеры								Детали	
		ØDmin	ØD	f	L	L1	H	a° В С		 ВИНТ	 КЛЮЧ
S16Q-SVZ*R/L11	VC__1103__	22	16	11.5	180	34	15	10°	8°	M2.5X8	T8
S20R-SVZ*R/L11	VB__1103__	27	20	14	200	38	19	8°	6°		
S25S-SVZ*R/L16	VC__1604__ VB__1604__	34	25	19.5	250	50	20	8°	6°	M4X10	T15
S32T-SVZ*R/L16		42	32	23.5	300	50	30	10°	8°		
S40U-SVZ*R/L16		50	40	27	350	60	38	8°	6°		

Тип S

SVW*R/L

Угол в плане 72.5°
Профильная обработка и растачивание глухих отверстий

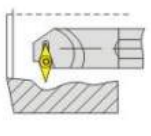
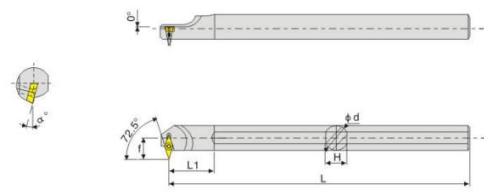
											
Модель	Пластина	Размеры							Детали		
		ØDmin	ØD	f	L	L1	H	a°	ВИНТ	КЛЮЧ	
S25S-SVW*R/L16	VC__1604__	38	25	23	250	33	24	6° 5°	M4X10	T15	
S32T-SVW*R/L16	VB__1604__	45	32	26	300	41	30	6° 5°			

Тип S

SWLCR/L

Угол в плане 95°
Обработка торцов, растачивание глухих и сквозных отверстий

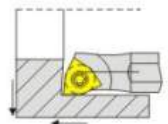
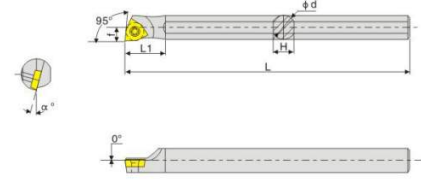
													
Модель	Пластина	Размеры							Детали				
		ØDmin	ØD	f	L	L1	H	a°	ВИНТ	КЛЮЧ			
S08K-SWLCR/L04	WC__0402__	10	8	5	125	25	7	13°	M3X6	T10			
S10K-SWLCR/L04		13	10	6.5	125	30	9	10°					
S12M-SWLCR/L06	WC__06T3__	16	12	7.5	150	37	11	13°	M3.5X10	T15			
S16Q-SWLCR/L06		20	16	9.5	180	40	15	10°					
S20R-SWLCR/L06		25	20	11.5	200	40	19	8°					
S25S-SWLCR/L06		31	25	14	250	40	24	6°					

Тип S

SDXCR/L

Угол в плане 95°
Обработка торцов, растачивание глухих и сквозных отверстий

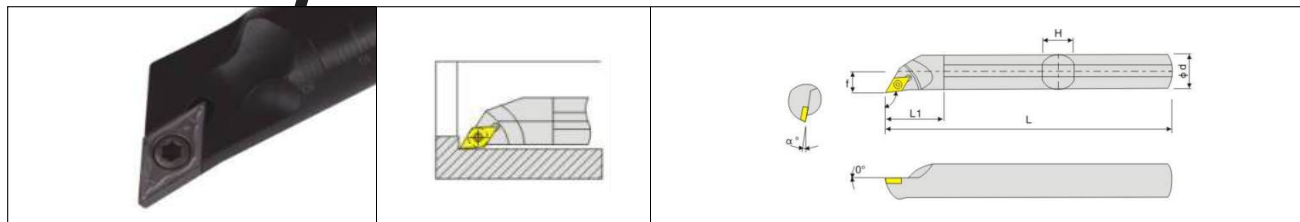

Модель	Пластина 	Размеры							Детали	
		ØDmin	ØD	f	L	L1	H	a°	 ВИНТ	 КЛЮЧ
S08K-SDXCR/L07	DC*T0702**	10	8	5	125	20	7	12°	M2.5X6	T8
S10K-SDXCR/07		13	10	6	125	25	9	10°		
S12M-SDXCR/L07		16	12	7	150	30	11	8°		
S16Q-SDXCR/L07		20	16	9	180	30	15	6°		
S20R -SDXCR/L11	DCMT 11T3....	25	20	11.5	200	40	19	6°	M4X8	T15
S25S-SDXCR/11		32	25	14	250	40	24	4°		

Тип S

STU_R/L

Угол в плане 93°
Токарная обработка

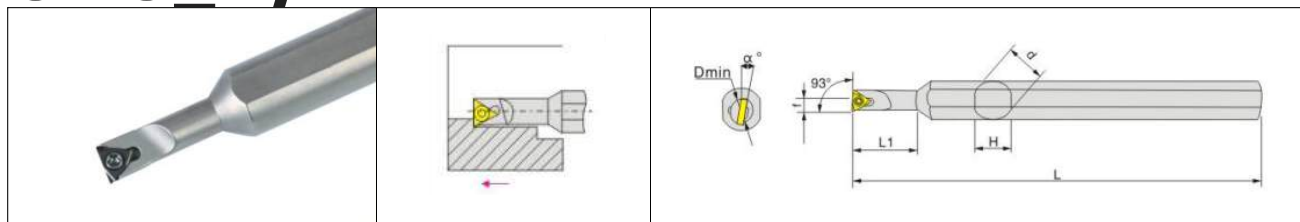

Модель	Пластина 	Размеры							Детали	
		ØDmin	ØD	f	L	L1	H	a°	 ВИНТ	 КЛЮЧ
S07K-STUPR/L08-A12	TP__0802__	9	12	4.5	125	25	11	12°	M2.2X6	T6
S08M-STUPR/L08-A16		10	16	5	150	28	15	13°		
S08K-STUCR/L09-A12	TP__0902__	10	12	5.5	125	28	11	15°	M2.5X6	T8
S08M-STUCR/L09-A16		10	16	5.5	150	28	15	10°		
S10M-STUCR/L11-A16	TP__1102__	12	16	6	150	30	15	12°	M2.5X6	T8
S12M-STUCR/L11-A16		14	16	7	150	33	15	10°		
S10M-STUPR/L11-A16		12	16	6	150	30	15	12°		
S12M-STUPR/L11-A16	TP__1103__	14	16	7	150	33	15	10°	M3X8	T8

Тип S

SWUBR/L

Угол в плане 93°
Токарная обработка

Модель	Пластина	Размеры							Детали	
		ØDmin	ØD	f	L	L1	H	α°	ВИНТ	КЛЮЧ
S06H-SWUBR/L06	WBGТ060102	7	6	3.5	100	16	5.4	15°	M2.2X6	T6
S0705H-SWUBR/L06		6	7	3	100	16	6	15°		
S0805H-SWUBR/L06		6	8	3	100	16	7	15°		
S1005K-SWUBR/L06		6	10	3	125	16	9	15°		
S1205K-SWUBR/L06		6	12	3	125	20	11	13°		
S1605K-SWUBR/L06		6	16	3	125	20	15	15°		
S0806J-SWUBR/L06		7	8	3.5	110	20	7	15°		
S1006K-SWUBR/L06		7	10	3.5	125	20	9	12°		
S1207K-SWUBR/L06		8	12	4	125	25	11	12°		
S1607M-SWUBR/L06		8	16	4	150	25	15	12°		

Тип S

C - SCLCR/L

Угол в плане 95°
Обработка торцов, растачивание



Модель	Пластина	Размеры							Детали	
		ØDmin	ØD	f	L	L1	H	α°	ВИНТ	КЛЮЧ
C06K-SCLCR/L06	CC_0602__	8	6	4.2	125	16	5	15°	M2.5X8	T6
C07K-SCLCR/L06		8	7	4.2	125	16	5	15°	M2.5X8	T8
C08K-SCLCR/L06		10	8	5	125	16	7	15°	M2.5X8	T8
C10K-SCLCR/L06		12	10	6	125	16	9	13°	M2.5X8	T8
C12M-SCLCR/L06		14	12	7	150	20	11	10°	M2.5X10	T8
C12M-SCLCR/L09	CC_09T3__	16	12	8.5	150	20	11	10°	M4X10	T15
C14Q-SCLCR/L09		17	14	9	180	20	13	11°	M4X10	T15
C16Q-SCLCR/L09		19	16	9.5	180	20	15	12°	M4X10	T15
C10M-SCLCR/L06	CC_0602__	12	10	6	150	25	9	13°	M2.5X6	T8

Тип S

C - STU /L

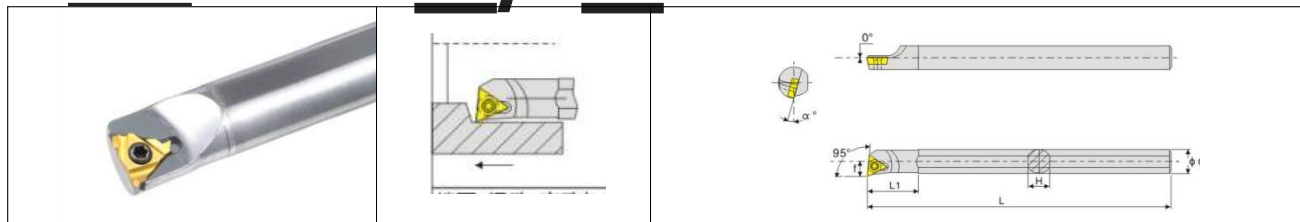
Угол в плане 95°
Обработка торцов, растачивание



Модель	Пластина 	Размеры							Детали	
		ØDmin	ØD	f	L	L1	H	α°	 ВИНТ	 КЛЮЧ
C06K-STUBR/L06	TB_0602__	7	6	4.2	125	25	5	13°	M2.2X5	T6
C08K-STUPR/L09	TP_0902__	10	8	4.2	125	28	7	15°	M2.2X5	T6
C10K-STUCR/L11	TC_1102__	12	10	5	125	28	9	12°	M2.5X6	T8
C10K-STUPR/L09	TP_0902__	12	10	6	125	28	9	13°	M2.2X5	T6
C10K-STUPR/L1103	TP_0903__	12	10	7	125	30	9	12°	M2.5X8	T8
C12M-STUCR/L11	TC_1102__	14	12	8.5	150	33	11	10°	M2.5X6	T8
C12M-STUPR/L1103	TP_0903__	14	12	9	150	30	11	10°	M2.5X8	T8
C10M-STUCR/L11	TC_1102__	12	10	9.5	150	33	9	10°	M2.5X6	T8

Тип S

C - STFBR/L 11

Угол в плане 91°
Растачивание

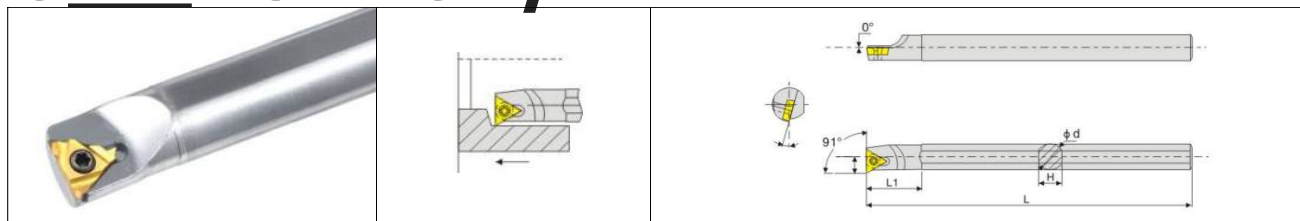

Модель	Пластина 	Размеры							Детали	
		ØDmin	ØD	f	L	L1	H	α°	 ВИНТ	 КЛЮЧ
C06K-STFBR/L06	TB_0602__	7	6	4.2	125	25	5	13°	M2.2X5	T6
C08K-STFPR/L09	TP_0902__	10	8	4.2	125	28	7	15°	M2.2X5	T6
C10K-STFCR/L11	TC_1102__	12	10	5	125	28	9	12°	M2.5X6	T8
C10K-STFPR/L09	TP_0902__	12	10	6	125	28	9	13°	M2.2X5	T6
C10K-STFPR/L1103	TP_0903__	12	10	7	125	30	9	12°	M2.5X8	T8
C12M-STFCR/L11	TC_1102__	14	12	8.5	150	33	11	10°	M2.5X6	T8
C12M-STFPR/L1103	TP_0903__	14	12	9	150	30	11	10°	M2.5X8	T8
C10M-STFCR/L11	TC_1102__	12	10	9.5	150	33	9	10°	M2.5X6	T8

Тип S

C K-SWUBR06

Угол в плане 91°
Растачивание

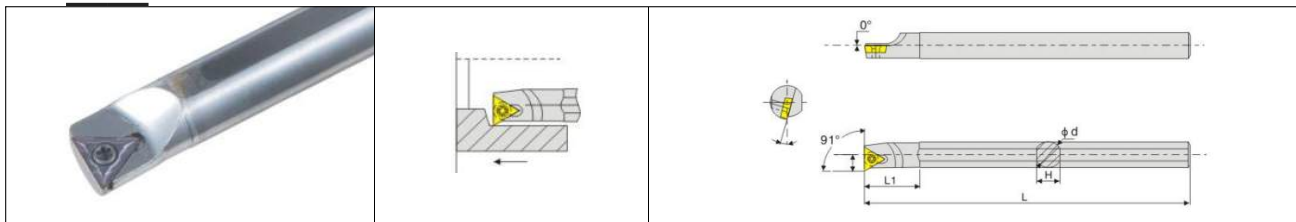

Модель	Пластина 	Размеры							Детали	
		ØDmin	ØD	f	L	L1	H	α°	 ВИНТ	 КЛЮЧ
C06K-SWUBR06	WBG060102	8	6	3.5	125	16	5	13°	M2.2X6	T6





Державки для обработки резьб

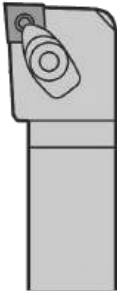
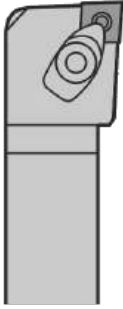
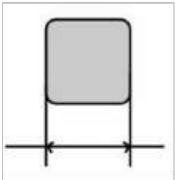
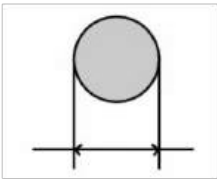

Геометрические параметры державок

S	E	R	2020	K																										
<p>1 тип крепления</p> <p>D режущая пластина фиксируется прижимом</p> <p>S режущая пластина фиксируется винтом</p>	<p>2 тип резьбы</p> <p>E внешняя резьба</p> <p>I внутренняя резьба</p>	<p>3 направление</p>  <p>R</p>  <p>L</p>	<p>размер внешней резьбы хвостовика 2020=20ммx20мм</p>  <p>размер диаметра внутренней резьбы 0020=Durchm. 20мм</p> 	<p>5 длина</p> <table border="1"> <thead> <tr> <th>обозначение, мм</th> <th>длина, мм</th> </tr> </thead> <tbody> <tr><td>D</td><td>60</td></tr> <tr><td>F</td><td>80</td></tr> <tr><td>H</td><td>100</td></tr> <tr><td>K</td><td>125</td></tr> <tr><td>L</td><td>140</td></tr> <tr><td>M</td><td>150</td></tr> <tr><td>P</td><td>170</td></tr> <tr><td>R</td><td>200</td></tr> <tr><td>S</td><td>250</td></tr> <tr><td>T</td><td>300</td></tr> <tr><td>U</td><td>350</td></tr> <tr><td>V</td><td>400</td></tr> </tbody> </table>	обозначение, мм	длина, мм	D	60	F	80	H	100	K	125	L	140	M	150	P	170	R	200	S	250	T	300	U	350	V	400
обозначение, мм	длина, мм																													
D	60																													
F	80																													
H	100																													
K	125																													
L	140																													
M	150																													
P	170																													
R	200																													
S	250																													
T	300																													
U	350																													
V	400																													
<p>16 O</p>																														
<p>6 размер пластины</p> <table border="1"> <thead> <tr> <th>L</th> <th>LC</th> </tr> </thead> <tbody> <tr><td>06</td><td>5/32"</td></tr> <tr><td>08</td><td>3/16"</td></tr> <tr><td>08U</td><td>3/16" U</td></tr> <tr><td>11</td><td>1/4"</td></tr> <tr><td>16</td><td>3/8"</td></tr> <tr><td>22</td><td>1/2"</td></tr> <tr><td>22U</td><td>1/2" U</td></tr> <tr><td>27</td><td>5/8"</td></tr> <tr><td>27U</td><td>5/8" U</td></tr> <tr><td>33</td><td>3/4"</td></tr> <tr><td>33U</td><td>3/4" U</td></tr> </tbody> </table>	L	LC	06	5/32"	08	3/16"	08U	3/16" U	11	1/4"	16	3/8"	22	1/2"	22U	1/2" U	27	5/8"	27U	5/8" U	33	3/4"	33U	3/4" U	<p>B с каналами для внутреннего подвода СОЖ</p> <p>C твердосплавные сверла</p> <p>V вертикальное исполнение</p> <p>O сверхточное исполнение</p> <p>D для внешнего подвода</p> <p>G антивибрационная державка</p> <p>U -образное исполнение</p>					
L	LC																													
06	5/32"																													
08	3/16"																													
08U	3/16" U																													
11	1/4"																													
16	3/8"																													
22	1/2"																													
22U	1/2" U																													
27	5/8"																													
27U	5/8" U																													
33	3/4"																													
33U	3/4" U																													

Содержание

SER/L	188
B-SER/L	188
DER	189
SER	189
SNR/L	190
SIR	190
CNR00	191
DIR	191



SER/L

Модель	Резец	Пластина	Размеры						Детали			
			h	b	L	f	h1	L1	подкладная пластина	винт	ключ	
SER/L	1212H16	16/ER/L_	12	12	100	16	12	20	-	M3.5X9	T8	
	1616H16		16	16	100	20	16	22	STM1603	M3.5X12	T15	
	2020K16		20	20	125	25	20	22	STM1603	M3.5X12	T15	
	2525M16		35	25	150	32	25	22	STM1603	M3.5X12	T15	
	3232P16		32	32	170	40	32	22	STM1603	M3.5X12	T15	

B-SER/L

Модель	Резец	Пластина	Размеры						Детали			
			h	b	L	f	h1	L1	подкладная пластина	винт	ключ	
B-SER/L	1212H16	16/EP/L_	12	12	100	16	12	20	-	M3.5X9	T15	
	1616H16		16	16	100	20	16	22	STM1603	M3.5X12	T15	
	2020K16		20	20	125	25	20	22	STM1603	M3.5X12	T15	
	2525M16		35	25	150	32	25	22	STM1603	M3.5X12	T15	
	3232P16		32	32	170	40	32	22	STM1603	M3.5X12	T15	

DER

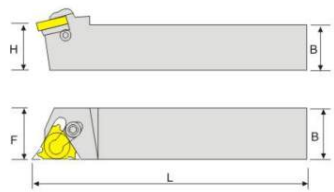
Модель		B=H	L	F	винт крепления пластин	пластина	распорный винт	ключ TORX	подкладная пластина правая	подкладная пластина левая
DER1212H16	16	12	100	16	S16	C16	A16S	K16	AE16	AI16
DER1616H16	16	16	100	16	S16	C16	A16S	K16	AE16	AI16
DER2020K18	16	20	125	20	S16	C16	A16S	K16	AE16	AI16
DER2525M16	16	25	150	25	S16	C16	A16S	K16	AE16	AI16
DER2525M15	22	25	150	25	S22	C22	A22	K22	AE22	AI22

SER

Модель		B=H	L	F	винт крепления пластин	ключ TORX
SER1616H16	16	16	100	18	S16S	K16
SER2020K16	16	20	125	22	S16S	K16
SER2525M16	16	25	150	27	S16S	K16
SER2525M22	22	25	150	27.5	S22S	K22

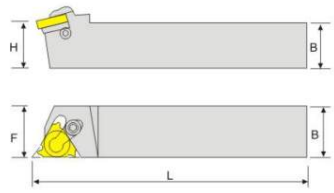
SNR/L

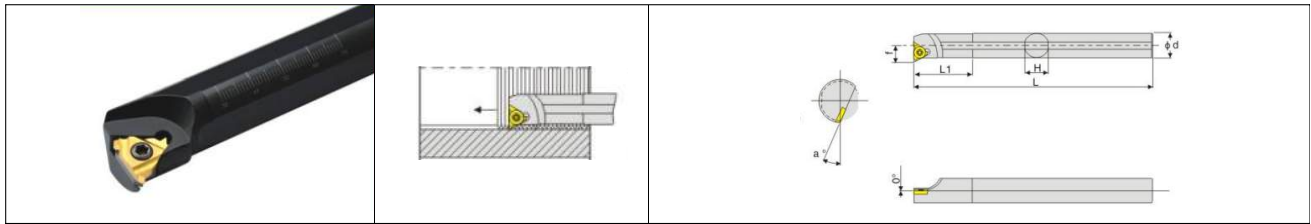

Модель	Резец	Пластина	Размеры							Детали		
			ØDmin	ØD	H	L	L1	f	a°	подкладная пластина	винт	ключ
SNR/L	0010K11	11/NR/L_	13	10	9	125	22	7.2	15°	-	M2.5X6	T8
	0012M11	11/NR/L_	15	12	11	150	22	8.5	15°	-	M2.5X6	T8
	0013M16	16/NR/L_	16	16	15	150	32	10.2	17°	-	M3.5X9	T15
	0016M16	16/NR/L_	19	16	15	150	40	11.7	15°	-	M3.5X9	T15
	0020Q16	16/NR/L_	24	20	19	180	40	13.7	21°	STM1603	M3.5X12	T15
	0025R16	16/NR/L_	29	25	24	200	45	16.2	21°	STM1603	M3.5X12	T15
	0032S16	16/NR/L_	36	32	30	250	50	19.7	15°	STM1603	M3.5X12	T15
	0040T16	16/NR/L_	44	40	38	300	55	23.7	15°	STM1603	M3.5X12	T15
0050r16	16/NR/L_	54	50	48	350	60	28.7	15°	STM1603	M3.5X12	T15	

SIR

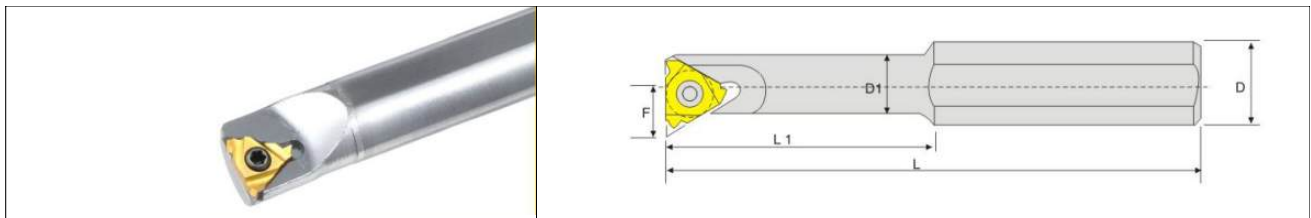

Модель		D	D1	Dmin	L	L1	F	винт крепления пластин	распорный винт	ключ TORX	подкладная пластина правая	подкладная пластина левая
*SIR0010M11-A16	11	16	10	12	150	28	7.4	M2.5*6	-	T8	-	-
*SIR0012M11-A16	11	16	12	14	150	32	8.2	M2.5*6	-	T8	-	-
*SIR0013M16-A16	16	16	13	17	150	37	9.2	M3.5*9	-	T15	-	-

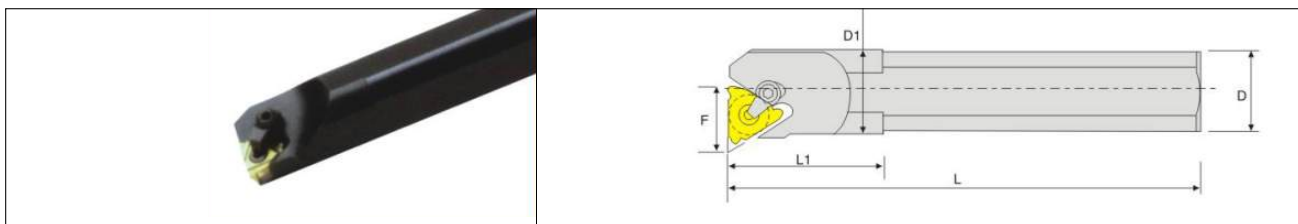

DIR

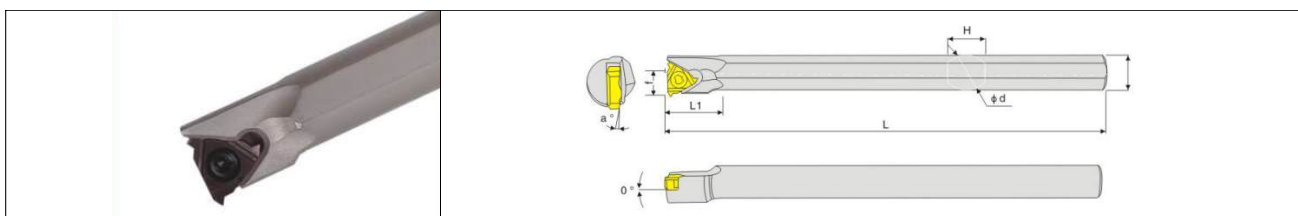

Модель		D	D1	Dmin	L	L1	F	винт крепления пластин	пластина	распорный винт	ключ TORX	подкладная пластина правая	подкладная пластина левая
DIR0020R16	16	20	20	24	170	-	13.7	S16	C16	A16	K16	AI16	AE16
DIR0025R16	16	25	25	29	200	-	16.2	S16	C16	A16	K16	AI16	AE16
DIR0032S16	16	32	32	38	250	-	19.7	S16	C16	A16	K16	AI16	AE16
DIR0025R22	22	25	25	29	200	-	18.1	S22	C22	A22	K22	AI22	AE22
DIR0032R22	22	32	32	38	250	-	20.2	S22	C22	A22	K22	AI22	AE22

CNR00



Модель	Пластина 	Размеры							Детали	
		ØDmin	ØD	H	L	L1	f	α°	 ВИНТ	 КЛЮЧ
CNR0007K08	08NRM_	10	7	6	125	16	5	18°	M2.5X5	T8
CNR0008K08	08NRM_	11	8	7	125	16	5.4	18°	M2.5X5	T8
CNR0010M11	11NRM_	13	10	9	150	16	6.4	15°	M2.5X9	T8
CNR0012M11	11NRM_	16	12	11	150	16	8.5	15°	M2.5X9	T8
CNR0014Q11	11NRM_	17	14	13	180	20	8.9	17°	M2.5X9	T8
CNR0016Q16	16NR_	20	16	15	180	20	10.2	15°	M3.5X9	T15



Канавочные резцы

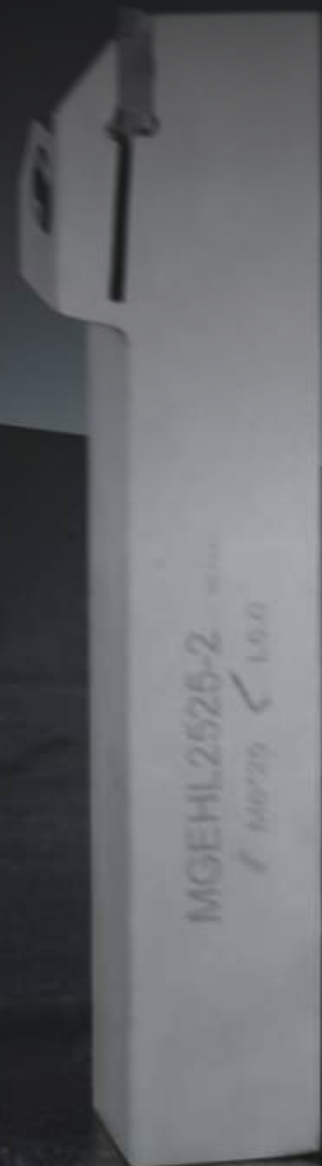

Содержание

MGEHR/L	9	KTGFR/L	9
MGIVR/L	9	STGFS	9
DBH	9	S-KTGFR/L	9
FGHH/FGVH	9	SMP05	9
ZQ**R/L	9	WTD	9
SGTR/L	9		
CGBR/L	9		
SPB	9		
SMBB	9		
SNGR/L	9		
SGB**R/L	9		
CGB**R/L	9		

MGEHR/L

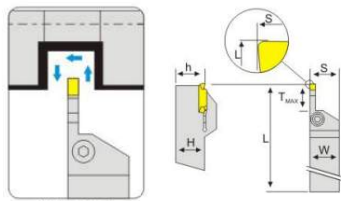

Модель	Размеры					Детали		
	H=(h)	W	L	S	Tmax	 подходящая пластина	 винт	 ключ
MGEHR1010-2	10	10	110	10.25	10	MGMN200-G 200-M	M5X16	T20
MGEHR1212-2	12	12	115	12.25	10	MGMN200-G 200-M	M4X16	L3
MGEHR1010-3	10	10	110	10.25	10	MGMN300-G 300-M	M5X16	T20
MGEHR1212-3	12	12	115	12.25	10	MGMN300-G 300-M	M4X16	L3
MGEHR1212-4	12	12	115	12.25	10	MGMN400-G 400-M	M4X16	L3
MGEHR1616-4	16	16	115	16.25	17	MGMN400-G 400-M	M6X25	L5
MGEHR/L1616-1.5	16	16	100	16.25	14.5	MGMN2150-G	M5X16	L4
MGEHR/L2020-1.5	20	20	125	20.25	14.5	MGMN2150-G	M5X16	L4
MGEHR/L2525-1.5	25	25	150	25.25	14.5	MGMN2150-G	M5X16	L4
MGEHR/L1212-2	12	12	100	14.25	14.5	MGMN200-G 200-M	M6X20	L5
MGEHR/L1616-2	16	16	100	16.25	14.5	MGMN200-G 200-M	M6X20	L5
MGEHR/L2020-2	20	20	125	20.25	14.5	MGMN200-G 200-M	M6X20	L5
MGEHR/L2525-2	25	25	150	25.25	14.5	MGMN200-G 200-M	M6X20	L5
MGEHR/L1616-2.5	16	16	100	16.30	16.5	MGMN250-G 250-M	M5X16	L5
MGEHR/L2020-2.5	20	20	125	20.30	16.5	MGMN250-G 250-M	M5X16	L5
MGEHR/L2525-2.5	25	25	150	25.30	16.5	MGMN250-G 250-M	M5X16	L5
MGEHR/L1616-3	16	16	100	16.35	18.5	MGMN300-G 300_-M MRMN300-G	M6X25	L5
MGEHR/L2020-3	20	20	125	20.4	18	MGMN300-G 300_-M MRMN300-G	M6X25	L5
MGEHR/L2020-3-T10	20	20	125	20.4	10	MGMN300-G 300_-M MRMN300-G	M6X25	L5
MGEHR/L2525-3	25	25	150	25.4	18	MGMN300-G 300_-M MRMN300-G	M6X25	L5
MGEHR/L2525-3-T10	25	25	150	25.4	10	MGMN300-G 300_-M MRMN300-G	M6X25	L5
MGEHR/L3232-3	32	32	170	32.4	18	MGMN300-G 300_-M MRMN300-G	M6X25	L5
MGEHR/L3232-3-T10	32	32	170	32.4	10	MGMN300-G 300_-M MRMN300-G	M6X25	L5
MGEHR/L2020-4	20	20	125	20.4	18	MGMN400-G 400_-M MRMN400-G	M6X25	L5
MGEHR/L2020-4-T10	20	20	125	20.4	10	MGMN400-G 400_-M MRMN400-G	M6X25	L5
MGEHR/L2525-4	25	25	150	25.4	18	MGMN400-G 400_-M MRMN400-G	M6X25	L5
MGEHR/L2525-4-T10	25	25	150	25.4	10	MGMN400-G 400_-M MRMN400-G	M6X25	L5
MGEHR/L3232-4	32	32	170	32.4	18	MGMN400-G 400_-M MRMN400-G	M6X25	L5
MGEHR/L3232-4-T10	32	32	170	32.4	10	MGMN400-G 400_-M MRMN400-G	M6X25	L5
MGEHR/L2020-5	20	20	150	20.5	23	MGMN500-G 500_-M MRMN500-G	M6X25	L5



MGEHR/L

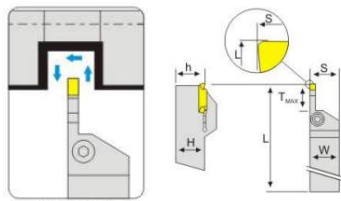

Модель	Размеры					Детали		
	H=(h)	W	L	S	Tmax	подходящая пластина	винт	ключ
MGEHR/L2020-5-T15	20	20	150	20.5	15	MGMN500-GJ500_-M MRMN500-G	M6X25	L5
MGEHR/L2525-5	25	25	150	25.5	23	MGMN500-GJ500_-M MRMN500-G	M6X25	L5
MGEHR/L2525-5-T15	25	25	150	25.5	15	MGMN500-GJ500_-M MRMN500-G	M6X25	L5
MGEHR/L3232-5	32	32	170	32.5	23	MGMN500-GJ500_-M MRMN500-G	M6X25	L5
MGEHR/L3232-5-T15	32	32	170	32.5	15	MGMN500-GJ500_-M MRMN500-G	M6X25	L5
MGEHR/L2020-6	20	20	1125	20.6	23	MGMN600-MJ600_-M MRMN600-M	M6X25	L5
MGEHR/L2020-6-T15	20	20	125	20.6	15	MGMN600-MJ600_-M MRMN600-M	M6X25	L5
MGEHR/L2525-6	25	25	150	25.6	23	MGMN600-MJ600_-M MRMN600-M	M6X25	L5
MGEHR/L2525-6-T15	25	25	150	25.6	15	MGMN600-MJ600_-M MRMN600-M	M6X25	L5
MGEHR/L3232-6	32	32	170	32.6	23	MGMN600-MJ600_-M MRMN600-M	M6X25	L5
MGEHR/L3232-6-T15	32	32	170	32.6	15	MGMN600-MJ600_-M MRMN600-M	M6X25	L5
MGEHR/L2525-8	25	25	150	26.1	28	MGMN800-M	M6X25	L5
MGEHR/L2525-8-T15	25	25	150	26.1	15	MGMN800-M	M6X25	L5
MGEHR/L3232-8	32	32	170	33.1	25	MGMN800-M	M6X25	L5
MGEHR/L3232-8-T15	32	32	170	33.1	16	MGMN800-M	M6X25	L5
MGEHR/L2525-6A	25	25	150	25.6	23	MGMN600-A	M6X25	L5
MGEHR/L2525-6A-T15	25	25	150	25.6	15	MGMN600-A	M6X25	L5
MGEHR/L3232-6A	32	32	170	32.6	23	MGMN600-A	M6X25	L5
MGEHR/L3232-6A-T15	32	32	170	32.6	15	MGMN600-A	M6X25	L5
MGEHR/L2525-8A	25	25	150	26.1	28	MGMN800-A	M6X25	L5
MGEHR/L2525-8A-T15	25	25	150	26.1	16	MGMN800-A	M6X25	L5
MGEHR/L3232-8A	32	32	170	33.1	28	MGMN800-A	M6X25	L5
MGEHR/L3232-8A-T15	32	32	170	33.1	15	MGMN800-A	M6X25	L5

MGIVR/L

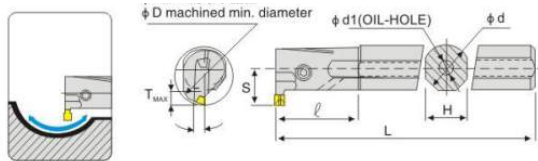

Модель	Размеры							Детали		
	ØD	Ød	L	l	Tmax	H	S	подходящая пластина	винт	ключ
MGIVR/L2016-1.5	20	16	125	35	4	15	11.3	MGMN150-G	M5X13	L2.5
MGIVR/L2520-1.5	25	20	150	45	4	18	13.1	MGMN150-G	M5X17	L4.0
MGIVR/L2925-1.5	29	25	200	45	4	23	16.2	MGMN150-G	M5X17	L4.0
MGIVR/L2016-2	20	16	125	35	5	15	12.4	MGMN200-G 200-M	M5X13	L2.5
MGIVR/L2520-2	25	20	150	45	5	18	14.0	MGMN200-G 200-M	M5X13	L2.5
MGIVR/L2925-2	29	25	200	45	5	23	17.2	MGMN200-G 200-M	M5X13	L2.5
MGIVR/L2016-2.5	20	16	125	35	6	15	12.5	MGMN250-G 250-M	M5X13	L4.0
MGIVR/L2520-2.5	25	20	150	35	6	18	15.1	MGMN250-G 250-M	M5X13	L2.5
MGIVR/L2925-2.5	29	25	200	35	6	23	18.2	MGMN300-M J300_-M MRMN300-M	M5X13	L2.5
MGIVR/L2520-3	25	20	150	45	6	18	15.6	MGMN300-M J300_-M MRMN300-M	M5X17	L4.0
MGIVR/L3125-3	31	25	200	45	6	23	18.9	MGMN300-M J300_-M MRMN300-M	M5X17	L4.0
MGIVR/L3732-3	37	32	250	65	6	30	21.5	MGMN400-M J400_-M MRMN400-M	M5X17	L4.0
MGIVR/L2520-4	25	20	150	45	6	18	12.6	MGMN400-M J400_-M MRMN400-M	M5X17	L4.0
MGIVR/L3125-4	31	25	200	45	6	23	18.9	MGMN400-M J400_-M MRMN400-M	M5X17	L4.0
MGIVR/L3732-4	37	32	250	65	6	30	21.5	MGMN500-M J500_-M MRMN500-M	M5X17	L4.0
MGIVR/L3135-5	31	35	200	45	8	23	19.4	MGMN500-M J500_-M MRMN500-M	M5X17	L4.0
MGIVR/L3732-5	37	32	250	65	8	30	21.5	MGMN600-M J600_-M MRMN600-M	M5X17	L4.0
MGIVR/L3125-6	31	25	200	45	8	23	19.4	MGMN600-M J600_-M MRMN600-M	M5X17	L4.0
MGIVR/L3732-6	37	32	250	65	8	30	21.5	MGMN800-M	M5X17	L4.0
MGIVR/L3732-8	37	32	250	65	10	30	23.4	MGMN800-M	M5X17	L4.0
MGIVR/L4540-8	45	40	300	70	10	37	27.2	MGMN800-M	M5X17	L4.0
MGIVR/L3732-6A	37	32	200	45	8	23	19.4	MGMN600-A	M5X17	L4.0
MGIVR/L4540-6A	45	40	250	65	8	30	21.5	MGMN600-A	M5X17	L4.0
MGIVR/L3732-8A	37	32	250	65	10	30	23.4	MGMN800-A	M5X17	L4.0
MGIVR/L4540-8A	45	40	300	70	10	37	27.2	MGMN800-A	M5X17	L4.0

DBH

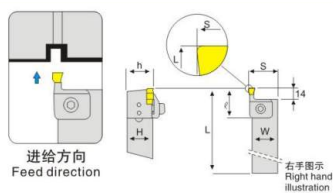

Модель	Размеры						Детали					
	H=(h)	W	L	I	S		подходящая пластина	пластина	опорный винт	винт	державка	ключ
DBH320R/L	20	20	150	40	22.3	22.8	DB300, *400**, DC300, 400	CGH5R1	M5X17	MHB0410	LD34	L3.0 4.0
DBH325R/L	25	25	150	40	27.3	27.8	DB300, *400**, DC300, 400	CGH5R1	M5X17	MHB0410	LD34	L3.0 4.0
DBH520R/L	20	20	150	40	23.8	24.3	DB500, 600, DC500	CGH5R2	M5X17	MHB0410	LD56	L3.0 4.0
DBH525R/L	25	25	150	40	28.8	29.3	DB500, 600, DC500	CGH5R2	M5X17	MHB0410	LD56	L3.0 4.0
DBH720R/L	20	20	150	40	25.3	26.6	DB700, 800	CGH5R3	M5X17	MHB0410	LD78	L3.0 4.0
DBH725R/L	25	25	150	40	30.8	31.3	DB700, 800	CGH5R3	M5X17	MHB0410	LD78	L3.0 4.0

FGHH/FGVH

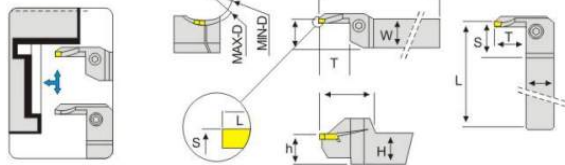

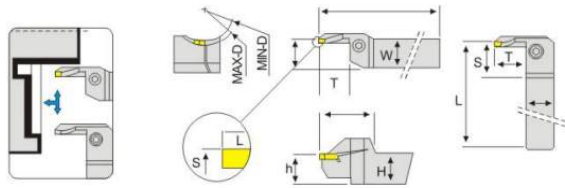

Модель	Размеры							Детали		
	H=(h)	W	L	S	Tmax	max	min	подходящая пластина	винт	ключ
FGHH/FGVH 320R-20/36	20	20	125	20.6	8	20	36	FMM300R-03	M6X25	L 5.0
25/30	20	20	125	20.6	12	25	30	FMM300R-03	M6X25	L 5.0
30/35	20	20	125	20.6	12	30	35	FMM300R-03	M6X25	L 5.0
30/50	20	20	125	20.6	12	30	50	FMM300R-03	M6X25	L 5.0
35/48	20	20	125	20.6	12	35	48	FMM300R-03	M6X25	L 5.0
48/60	20	20	125	20.6	22	48	60	FGD300R-03, FGM300R-03	M6X25	L 5.0
50/100	20	20	125	20.6	15	50	100	FGD300R-03, FGM300R-03	M6X25	L 5.0
60/75	20	20	125	20.6	22	60	75	FGD300R-03, FGM300R-03	M6X25	L 5.0
75/100	20	20	125	20.6	22	75	100	FGD300R-03, FGM300R-03	M6X25	L 5.0
80/160	20	20	125	20.6	17	80	160	FGD300R-03, FGM300R-03	M6X25	L 5.0
100/140	20	20	125	20.6	22	100	140	FGD300R-03, FGM300R-03	M6X25	L 5.0
160/400	20	20	125	20.6	17	160	400	FGD300R-03, FGM300R-03	M6X25	L 5.0
200/800	20	20	125	20.6	19	200	800	FGD300R-03, FGM300R-03	M6X25	L 5.0
FGHH/FGVH 325R-20/36	20	20	150	25.6	8	20	36	FMM300R-03	M6X25	L 5.0
25/30	25	25	150	25.6	12	25	30	FMM300R-03	M6X25	L 5.0
30/35	25	25	150	25.6	12	30	35	FMM300R-03	M6X25	L 5.0
30/50	20	20	150	25.6	12	30	50	FMM300R-03	M6X25	L 5.0
35/48	25	25	150	25.6	12	35	48	FMM300R-03	M6X25	L 5.0
48/60	25	25	150	25.6	22	48	60	FGD300R-03, FGM300R-03	M6X25	L 5.0
50/100	20	20	150	25.6	15	50	100	FGD300R-03, FGM300R-03	M6X25	L 5.0
60/75	25	25	150	25.6	22	60	75	FGD300R-03, FGM300R-03	M6X25	L 5.0
75/100	25	25	150	25.6	22	75	100	FGD300R-03, FGM300R-03	M6X25	L 5.0
80/160	20	20	150	25.6	17	80	160	FGD300R-03, FGM300R-03	M6X25	L 5.0
100/140	25	25	150	25.6	22	100	140	FGD300R-03, FGM300R-03	M6X25	L 5.0
160/400	20	20	150	25.6	17	160	400	FGD300R-03, FGM300R-03	M6X25	L 5.0
200/800	20	20	150	25.6	19	200	800	FGD300R-03, FGM300R-03	M6X25	L 5.0
FGHH/FGVH 420R-20/36	20	20	125	20.6	8	20	36	FMM400R-04	M6X25	L 5.0
25/30	20	20	125	20.6	12	25	30	FMM400R-04	M6X25	L 5.0
30/35	20	20	125	20.6	12	30	35	FMM400R-04	M6X25	L 5.0
30/50	20	20	125	20.6	12	30	50	FMM400R-04	M6X25	L 5.0

FGHH/FGVH





Модель	Размеры							Детали		
	H=(h)	W	L	S	Tmax	max	min	подходящая пластина	винт	ключ
35/48	20	20	125	20.6	12	35	48	FMM400R-04	M6X25	L 5.0
48/60	20	20	125	20.6	25	48	60	FGD400R-04, FGM400R-04	M6X25	L 5.0
50/100	20	20	125	20.6	15	50	100	FGD400R-04, FGM400R-04	M6X25	L 5.0
60/75	20	20	125	20.6	25	60	75	FGD400R-04, FGM400R-04	M6X25	L 5.0
75/100	20	20	125	20.6	25	75	100	FGD400R-04, FGM400R-04	M6X25	L 5.0
80/160	20	20	125	20.6	17	80	160	FGD400R-04, FGM400R-04	M6X25	L 5.0
100/140	20	20	125	20.6	25	100	140	FGD400R-04, FGM400R-04	M6X25	L 5.0
160/400	20	20	125	20.6	17	160	400	FGD400R-04, FGM400R-04	M6X25	L 5.0
200/800	20	20	125	20.6	19	200	800	FGD400R-04, FGM400R-04	M6X25	L 5.0
FGHH/FGVH 425R-20/36	25	25	150	25.6	8	20	36	FMM400R-04	M6X25	L 5.0
25/30	20	20	150	25.6	12	25	30	FMM400R-04	M6X25	L 5.0
30/35	25	25	150	25.6	12	30	35	FMM400R-04	M6X25	L 5.0
30/50	20	20	150	25.6	12	30	50	FMM400R-04	M6X25	L 5.0
35/48	25	25	150	25.6	12	35	48	FMM400R-04	M6X25	L 5.0
48/60	25	25	150	25.6	25	48	60	FGD400R-04, FGM400R-04	M6X25	L 5.0
50/100	20	20	150	25.6	15	50	100	FGD400R-04, FGM400R-04	M6X25	L 5.0
60/75	25	25	150	25.6	25	60	75	FGD400R-04, FGM400R-04	M6X25	L 5.0
75/100	25	25	150	25.6	25	75	100	FGD400R-04, FGM400R-04	M6X25	L 5.0
80/160	20	20	150	25.6	17	80	160	FGD400R-04, FGM400R-04	M6X25	L 5.0
100/140	20	20	150	25.6	25	100	140	FGD400R-04, FGM400R-04	M6X25	L 5.0
160/400	20	20	150	25.6	17	160	400	FGD400R-04, FGM400R-04	M6X25	L 5.0
200/800	20	20	150	25.6	19	200	800	FGD400R-04, FGM400R-04	M6X25	L 5.0
FGHH/FGVH 520R-25/30	20	20	125	20.6	12	25	30	FMM500R-04	M6X25	L 5.0
30/35	20	20	125	20.6	12	30	35	FMM500R-04	M6X25	L 5.0
35/40	20	20	125	20.6	20	35	40	FMM500R-04	M6X25	L 5.0
40/48	20	20	125	20.6	20	40	48	FMM500R-04	M6X25	L 5.0
48/60	20	20	125	20.6	25	48	60	FGD500R-04, FGM500R-04	M6X25	L 5.0
60/75	20	20	125	20.6	25	60	75	FGD500R-04, FGM500R-04	M6X25	L 5.0
75/140	20	20	125	20.6	25	75	140	FGD500R-04, FGM500R-04	M6X25	L 5.0
100/140	20	20	125	20.6	25	100	140	FGD500R-04, FGM500R-04	M6X25	L 5.0

FGHH/FGVH



Модель	Размеры							Детали		
	H=(h)	W	L	S	Tmax	max	min	 подходящая пластина	 винт	 ключ
FGHH/FGVH 525R-25/30	25	25	150	25.6	12	25	30	FMM500R-04	M6X25	L 5.0
30/35	25	25	150	25.6	12	30	35	FMM500R-04	M6X25	L 5.0
35/40	25	25	150	25.6	20	35	40	FMM500R-04	M6X25	L 5.0
40/48	25	25	150	25.6	20	40	48	FMM500R-04	M6X25	L 5.0
48/60	25	25	150	25.6	25	48	60	FGD500R-04, FGM500R-04	M6X25	L 5.0
60/75	25	25	150	25.6	25	60	75	FGD500R-04, FGM500R-04	M6X25	L 5.0
75/140	25	25	150	25.6	25	75	140	FGD500R-04, FGM500R-04	M6X25	L 5.0
100/140	25	25	150	25.6	25	100	140	FGD500R-04, FGM500R-04	M6X25	L 5.0

SGTR/R

Модель	Размеры							Детали		
	w	b	h	L	L1	h1	f	 подходящая пластина	 винт	 ключ
SGTR/L 1616H16	0.33-2.5	16	16	100	22	16	20	GTR/L 32	M4X10	T15
SGTR/L 2020K16	0.33-2.5	20	20	125	26	20	25	GTR/L 32	M4X10	T15
SGTR/L 2525M16	0.33-2.5	25	25	150	26	25	32	GTR/L 32	M4X10	T15
SGTR/L 2020K22-1	1.25-1.85	20	20	125	26	20	25	GTR/L 43125-185	M5X12	T20
SGTR/L 2020K22-2	2.0-2.8	20	20	125	26	20	25	GTR/L 43200-280	M5X12	T20
SGTR/L 2020K22-3	3.0-4.5	20	20	125	26	20	25	GTR/L 43300-450	M5X12	T20
SGTR/L 2525M22-1	1.25-1.85	25	25	150	26	25	32	GTR/L 43125-185	M5X12	T20
SGTR/L 2525M22-2	2.0-2.8	25	25	150	26	25	32	GTR/L 43200-280	M5X12	T20
SGTR/L 2525M22-3	3.0-4.5	25	25	150	26	25	32	GTR/L 43300-450	M5X12	T20

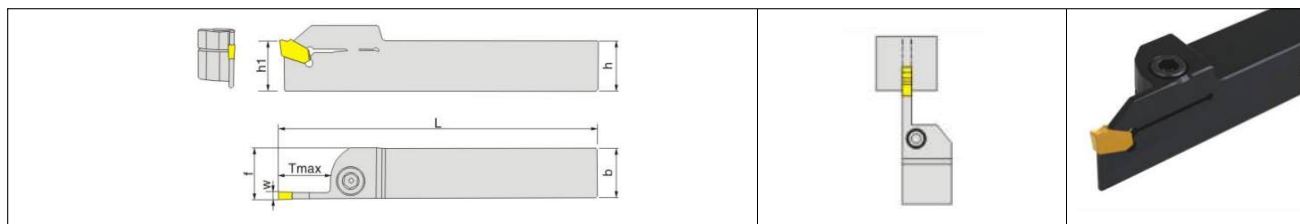
ZQ_R/L



Модель	Размеры							Детали		
	w	b	h	L	h1	f	Tmax	 подходящая пластина	 винт	 ключ
ZQ1616R/L-03	3.125	16	16	100	16	16.4	18	SP300	M5X25	L4
ZQ2020R/L-03	3.125	20	20	125	20	20.4	20	SP300	M5X25	L4
ZQ2525R/L-03	3.125	25	25	150	25	25.4	20	SP300	M5X25	L4
ZQ3225R/L-03	3.125	25	32	170	32	25.4	25	SP300	M5X25	L4
ZQ1616R/L-04	4.125	16	16	100	16	16.4	18	SP400	M6X25	L5
ZQ2020R/L-04	4.125	20	20	125	20	20.4	20	SP400	M6X25	L5
ZQ2525R/L-04	4.125	25	25	150	25	25.4	20	SP400	M6X25	L5
ZQ3225R/L-04	4.125	25	32	170	32	25.4	25	SP400	M6X25	L5
ZQ2525R/L-05	5.125	25	25	150	25	25.5	25	SP500	M6X25	L5
ZQ3232R/L-05	5.125	32	32	170	32	32.5	25	S500	M6X25	L5
ZQ2525R/L-06	6.4	25	25	150	25	25.5	32	SP600	M6X25	L5
ZQ3232R/L-06	6.4	32	32	170	32	32.5	32	SP600	M6X25	L5

CGBR/L

Модель	Размеры							Детали			
	w	b	h	L	L1	h1	f				
CGBR/L 1616H16	0.5-2.5	16	16	100	22	16	20	GB32R/L	HL1808	M3.5X10 ML0520	T20 L2.5
CGBR/L 2020K18	0.5-2.5	20	20	125	26	20	25	GB32R/L	HL1808	M3.5X10 ML0520	T20 L2.5
CGBR/L 2525M16	0.5-2.5	25	25	150	26	25	32	GB32R/L	HL1808	M3.5X10 ML0520	T20 L2.5
CGBR/L 2020K22-1	1.25-1.85	20	20	125	26	20	25	GB43R/L 125-185	HL1808	M5X12 ML0520	T20 L2.5
CGBR/L 2020K22-2	2.0-2.8	20	20	125	26	20	25	GB43R/L 200-280	HL1808	M5X12 ML0520	T20 L2.5
CGBR/L 2020K22-3	3.0-4.5	20	20	125	26	20	25	GB43R/L 300-450	HL1808	M5X12 ML0520	T20 L2.5
CGBR/L 2525M22-1	1.25-1.85	25	25	150	26	25	32	GB43R/L 125-185	HL1808	M5X12 ML0520	T20 L2.5
CGBR/L 2525M22-2	2.0-2.8	25	25	150	26	25	32	GB43R/L 200-280	HL1808	M5X12 ML0520	T20 L2.5
CGBR/L 2525M22-3	3.0-4.5	25	25	150	26	25	32	GB43R/L 300-450	HL1808	M5X12 ML0520	T20 L2.5

SPB

Модель	Размеры					Детали
	w	b	h	L	h1	
SPB26-2	2	1.6	26	26	21	SP200, 200R/L
SPB26-3	3	2.4	26	26	21	ZQMx3N-11-1E SP300, 300R/L
SPB26-4	4	3.2	26	26	21	ZQMx4N-11-1E SP400, 400R/L
SPB26-5	5	4.2	26	26	21	ZQMx5N-11-1E SP500, 500R/L
SPB32-2	2	1.6	32	32	27	SP200, 200R/L
SPB32-3	3	2.4	32	32	27	ZQMx3N-11-1E SP300, 300R/L
SPB32-4	4	3.2	32	32	27	ZQMx4N-11-1E SP400, 400R/L
SPB32-5	5	4.2	32	32	27	ZQMx5N-11-1E SP500, 500R/L
SPB32-6	6	5.2	32	32	27	ZQMx6N-11-1E SP600, 600R/L

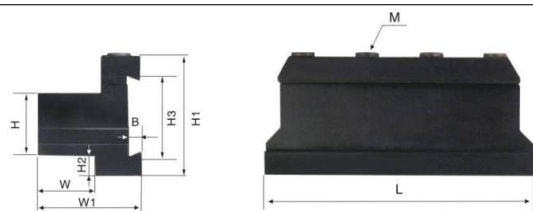

SMBB

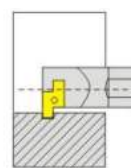
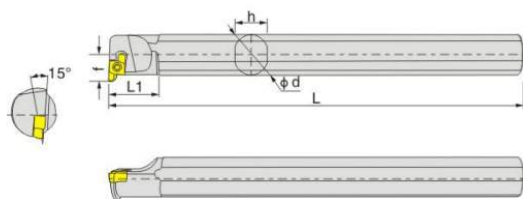

Модель	Размеры									Ключ 
	H	W	H3	L	H1	H2	W1	B	M	
SMBB1626	16	12	26	86	43	13	30	5.3	3-M6	L5
SMBB2026	20	19	26	86	43	9	30	5.3	3-M6	L5
SMBB2032	20	19	32	100	50	13	38	5.3	3-M6	L5
SMBB2526	25	23	26	86	43	4	42	5.3	4-M6	L5
SMBB2532	25	23	32	110	50	8	42	5.3	4-M6	L5
SMBB3232	32	30	32	110	54	5	30	5.3	4-M6	L5

SNGR/L







Модель	Размеры						Детали		
	Tmax	Ød	F	L1	L	H	 подходящая пластина	 винт	 ключ
S08H-SNGR/L06	2	8	4.7	15	100	7	6GR/L	M2.2x4	T7
S08H-SNGR/L07	2	8	5.8	15	100	7	7GR/L	M2.5x6	T7
S10K-SNGR/L07	2	10	6.8	15	125	8	7GR/L	M2.5x6	T7
S10K-SNGR/L08	3.5	10	7.6	20	125	8	8GR/L	M2.5x6	T7
S12M-SNGR/L08	3.5	12	8.6	20	150	11	8GR/L	M2.5x6	T7
S16Q-SNGR/L09	3.5	16	11.6	20	180	14.8	9GR/L	M2.5x6	T8
S20R-SNGR/L09	3.5	20	13.6	20	200	18.4	9GR/L	M2.5x6	T8
H08H-SNGR/L06	2	8	4.7	15	100	7	6GR/L	M2.2x4	T7
H08H-SNGR/L07	2	8	5.8	15	100	7	7GR/L	M2.5x6	T7
H10K-SNGR/L07	2	10	6.8	15	125	8	7GR/L	M2.5x6	T7
H10K-SNGR/L08	3.5	10	7.6	20	125	8	8GR/L	M2.5x6	T7
H12M-SNGR/L08	3.5	12	8.6	20	150	11	8GR/L	M2.5x6	T7
H16Q-SNGR/L09	3.5	16	11.6	20	180	14.8	9GR/L	M2.5x6	T8
H20R-SNGR/L09	3.5	20	13.6	20	200	18.4	9GR/L	M2.5x6	T8

SGB_R/L

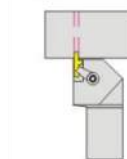
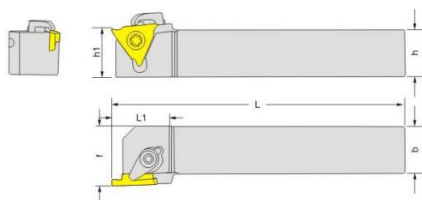
Модель	Размеры							Детали		
	w	b	h	L	L1	h1	f	подходящая пластина	винт	ключ
SGBR/L 1616H16	0.33-2.5	16	16	100	22	16	20	GBR/L32	M4x10	T15
SGBR/L 2020K16	0.33-2.5	20	20	125	26	20	25	GBR/L32	M4x10	T15
SGBR/L 2525M16	0.33-2.5	25	25	150	26	25	32	GBR/L32	M4x10	T15
SGBR/L 1616H22-1	1.25-1.85	16	16	100	26	16	20	GBR/L43125-185	M5x12	T20
SGBR/L 1616H22-2	2.0-2.8	16	16	100	26	16	20	GBR/L43200-280	M5x12	T20
SGBR/L 1616H22-3	3.0-4.5	16	16	100	26	16	20	GBR/L43300-450	M5x12	T20
SGBR/L 2020K22-1	1.25-1.85	20	20	125	26	20	25	GBR/L43125-185	M5x12	T20
SGBR/L 2020K22-2	2.0-2.8	20	20	125	26	20	25	GBR/L43200-280	M5x12	T20
SGBR/L 2020K22-3	3.0-4.5	20	20	125	26	20	25	GBR/L43300-450	M5x12	T20
SGBR/L 2525M22-1	1.25-1.85	25	25	150	26	25	32	GBR/L43125-185	M5x12	T20
SGBR/L 2525M22-2	2.0-2.8	25	25	150	26	25	32	GBR/L43200-280	M5x12	T20
SGBR/L 2525M22-3	3.0-4.5	25	25	150	26	25	32	GBR/L43300-450	M5x12	T20

CGB_R/L





Модель	Размеры							Детали			
	w	b	h	L	L1	h1	f				
CGBR/L 1616H16	0.5-2.5	16	16	100	22	16	20	GB32R/L	HL1808	M3.5x10 ML0520	T20 L2.5
CGBR/L 2020K16	0.5-2.5	16	16	125	22	20	25	GB32R/L	HL1808	M3.5x10 ML0520	T20 L2.5
CGBR/L 2525M16	0.5-2.5	16	16	150	22	25	32	GB32R/L	HL1808	M3.5x10 ML0520	T20 L2.5
CGBR/L 1616H22-1	1.28-1.85	16	16	100	26	16	20	GB43R/L125-185	HL1808	M5x12 ML0520	T20 L2.5
CGBR/L 1616H22-2	2.0-2.8	16	16	100	26	16	20	GB43R/L200-280	HL1808	M5x12 ML0520	T20 L2.5
CGBR/L 1616H22-3	3.0-4.5	16	16	100	26	16	20	GB43R/L300-450	HL1808	M5x12 ML0520	T20 L2.5
CGBR/L 2020K22-1	1.28-1.85	20	20	125	26	20	25	GB43R/L125-185	HL1808	M5x12 ML0520	T20 L2.5
CGBR/L 2020K22-2	2.0-2.8	20	20	125	26	20	25	GB43R/L200-280	HL1808	M5x12 ML0520	T20 L2.5
CGBR/L 2020K22-3	3.0-4.5	20	20	125	26	20	25	GB43R/L300-450	HL1808	M5x12 ML0520	T20 L2.5
CGBR/L 2525M22-1	1.28-1.85	25	25	150	26	25	32	GB43R/L125-185	HL1808	M5x12 ML0520	T20 L2.5
CGBR/L 2525M22-2	2.0-2.8	25	25	150	26	25	32	GB43R/L200-280	HL1808	M5x12 ML0520	T20 L2.5
CGBR/L 2525M22-3	3.0-4.5	25	25	150	26	25	32	GB43R/L300-450	HL1808	M5x12 ML0520	T20 L2.5



KTGFR/L

Модель	Размеры							Детали		
	w	b	h	L	L1	h1	f			
KTGFR/L 1616H-16F	0.75-2.0	16	16	100	22	16	16	TGF32R/L	M3.5x10	T15
KTGFR/L 2020K-16	0.75-2.0	20	20	125	26	20	20	TGF32R/L	M3.5x10	T15
KTGFR/L 2525M-16F	0.75-2.0	25	25	150	26	25	25	TGF32R/L	M3.5x10	T15
KTGFR/L 1616H-16	0.75-2.0	16	16	100	22	16	20	TGF32R/L	M3.5x10	T15
KTGFR/L 2020K-16	0.75-2.0	20	20	125	26	20	25	TGF32R/L	M3.5x10	T15
KTGFR/L 2525M-16	0.75-2.0	25	25	150	26	25	32	TGF32R/L	M3.5x10	T15
KTGFR/L 1616H-22	1.25-4.5	16	16	100	27	16	20	TGF43R/L	M5x12	T20
KTGFR/L 2020K-22	1.25-4.5	20	20	125	27	20	25	TGF43R/L	M5x12	T20
KTGFR/L 2525M-22	1.25-4.5	25	25	150	27	25	32	TGF43R/L	M5x12	T20



STGFS

Модель	Размеры						Детали		
	h	b	F1	h1	L2	L			
STGFSR/L 1616H16	16	16	20	16	20	100	TGFL/R32	M4x10	T15
STGFSR/L 2020K16	20	20	25	20	22	125	TGFL/R32	M4x10	T15
STGFSR/L 2525M16	25	25	32	25	25	150	TGFL/R32	M4x10	T15
STGFSR/L 2020K22	20	20	25	20	25	125	TGFL/R43	M5x10.5	T20
STGFSR/L 2525M22	25	25	32	25	26	150	TGFL/R43	M5x10.5	T20

S-KTGFR/L

Модель	Размеры					Детали		
	Tmax	Dim	Ød	L	H	 подходящая пластина	 винт	 ключ
S16Q-KTFGR/L 16	2.5	20	16	180	14.5	TGF32L/R	M4x10	T15
S20R-KTFGR/L 16	2.5	25	20	200	18.4	TGF32L/R	M4x10	T15
S25S-KTFGR/L 16	2.5	30	25	250	23	TGF32L/R	M4x10	T15
S32T-KTFGR/L 16	2.5	38	32	300	30	TGF32L/R	M4x10	T15

SMP05-_-_-TGF32T_-160

Модель	Размеры					Детали		
	L	L1	ØD	Ød	Tmax	 подходящая пластина	 винт	 ключ
SMP05-016-XP20-TGF32T1-160	160	65	20	11	16	GBR/L32	M4x8	T15
SMP05-020-XP20-TGF32T1-160	160	65	20	14	20	GBR/L32	M4x8	T15
SMP05-032-XP25-TGF32T3-160	160	26	25	24.6	31	GBR/L32	M4x8	T15

WTD

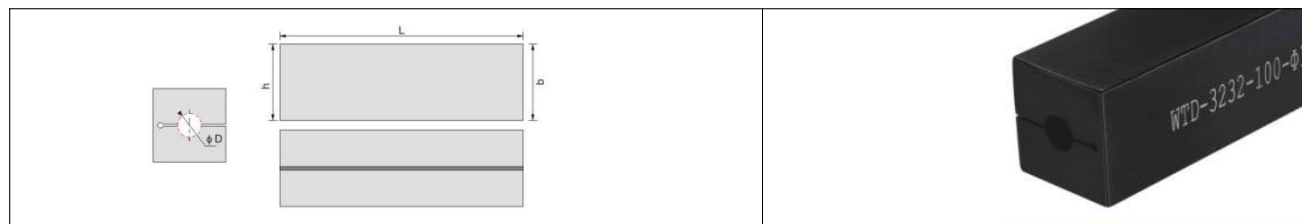

Модель	Размеры			
	ØD	b	h	L
1616-06	6	16	16	80
1616-07	7	16	16	80
1616-08	8	16	16	80
1616-10	10	16	16	80
2020-06	6	20	20	80
2020-07	7	20	20	80
2020-08	8	20	20	80
2020-10	10	20	20	80
2020-12	12	20	20	80
2020-14	14	20	20	80







Содержание



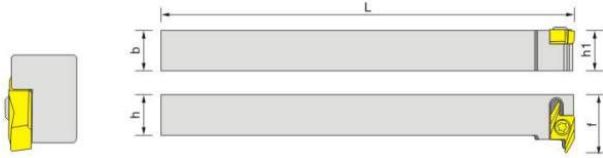

	B-SABSL	9
	SABSL	9
	SABW-50F	9
	CTPAR/L	9
	MGEHR	9
	SDJCR/L	9
	SVJBR/L	9
	LF-C-*-*-*-L-1T	9

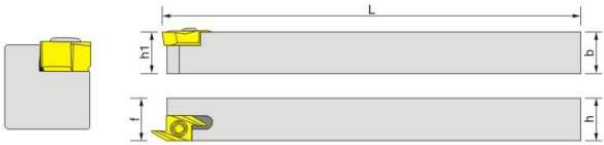

B-SABSL__JX40F

									
Модель	Размеры						Детали		
	b	h	L	h1	f	Tmax	 подходящая пластина	 винт	 ключ
B-SABSL0808JX40F	8	8	100	8	16.6	4.2	ABS15R/L40-__	M3x8	T8
B-SABSL1010JX40F	10	10	110	10	10	4.2	ABS15R/L40-__	M3x8	T8
B-SABSL1212JX40F	12	12	120	12	17.6	4.2	ABS15R/L40-__	M3x8	T8

SABSL

									
Модель	Размеры						Детали		
	b	h	L	h1	f	Tmax	 подходящая пластина	 винт	 ключ
SABSL0808JX40F	8	8	100	8	16.6	4.2	ABS15R/L40-__	M3x8	T8
SABSL1010JX40F	10	10	110	10	10	4.2	ABS15R/L40-__	M3x8	T8
SABSL1212JX40F	12	12	120	12	17.6	4.2	ABS15R/L40-__	M3x8	T8

SABW-50F

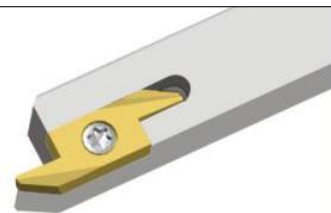
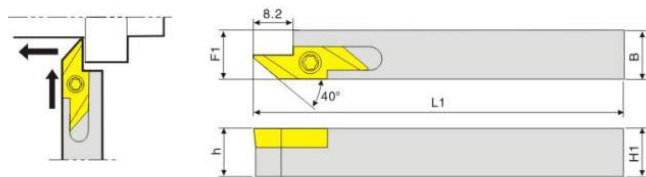



Модель	Размеры								Детали	
	H1=h	H2	B	L1	L2	F1	R	Наличие	 ВИНТ	 КЛЮЧ
SABEWR1010JX-50F	10	-	10	120	-	10.2	0.15	●	SB-3080TR	FT-10
SABEWR1212JX-50F	12	-	12	120	-	12.2	0.15	●	SB-3080TR	FT-10
SABEWR1616JX-50F	16	-	16	120	-	16.2	0.15	●	SB-3080TR	FT-10
SABEWR2020K-50F	20	-	20	125	-	20.2	0.15	●	SB-3080TR	FT-10

СТРА/L





Модель	Размеры						Детали		
	b	h	L	h1	f	Tmax	 подходящая пластина	 ВИНТ	 КЛЮЧ
СТРА/L08	8	8	100	8	8	5.5	СТР07-20FR/L_	M4x10	T15
СТРА/L10	10	10	110	10	10	5.5	СТРАХ15-20FR/L_	M4x10	T15
СТРА/L12	12	12	120	12	12	5.5	СТРАХ15-20FR/L_	M4x10	T15





MGEHR___-J

Модель	Размеры						Детали		
	b	h	L	h1	f	Tmax	 подходящая пластина	 винт	 ключ
MGEHR1212-J1.5D24	12	12	110	12	12	24	MGMN150-M	M4x12	T15
MGEHR1212-J2D24	12	12	110	12	12	24	MGMN200-M	M4x12	T15
MGEHR1212-J2.5D30	12	12	110	12	12	30	MGMN250-M	M4x12	T15
MGEHR1212-J3D28	12	12	110	12	12	28	MGMN300-M	M4x12	T15



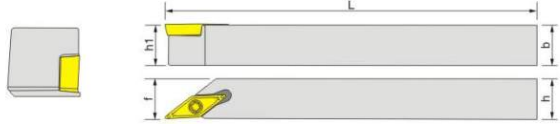

SDJCR/L___J

Модель	Размеры						Детали		
	b	h	L	h1	f	Tmax	 подходящая пластина	 винт	 ключ
SDJCR/L0808JX11N	8	8	100	8	12.5	-	DCMT 11T3**	M4x6	T15
SDJCR/L1010JX11N	10	10	110	10	12.5	-	DCMT 11T3**	M4x8	T15
SDJCR/L1212JX11N	12	12	110	12	12.5	-	DCMT 11T3**	M4x10	T15

SVJBR/L__J

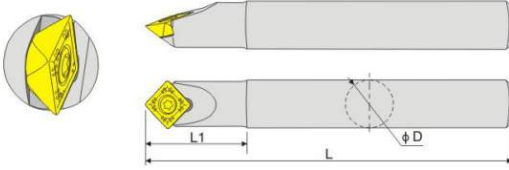
									
Модель	Размеры						Детали		
	b	h	L	h1	f	Tmax	 подходящая пластина	 винт	 ключ
SVJBR/L0808JX11N	8	8	100	8	10	-	VB*T 1103**	M2.5x6	T8
SVJBR/L1010JX11N	10	10	110	10	10	-	VB*T 1103**	M2.5x6	T8
SVJBR/L1212JX11N	12	12	110	12	12	-	VB*T 1103**	M2.5x6	T8

LF-C_--_L-1T

							
Модель	Размеры				Детали		
	L	L1	ØD	mm	 подходящая пластина	 винт	 ключ
LF-C10-10-100L-1T	100	21	10	0-6	SEME060202_	M2.5x5	T8
LF-C12-12-120L-1T	120	24	12	0-9	SEME090404_	M3.5x8	T15
LF-C16-16-120L-1T	120	35	16	0-12	SEME120404_	M4x8	T15

Твердосплавные расточные минирезцы



MTR _ R/L _

Для обработки отверстий диаметром от 2 до 10 мм. Внешний подвод СОЖ.

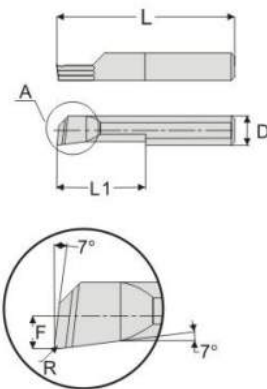
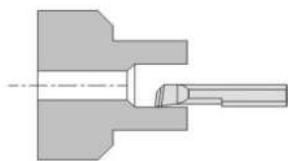

D	Обозначение	L	L1	R	F	Dmin
3.0	MTR 2 R0.15 L5	50	5	0.15	0.8	2.1
	MTR 2 R0.15 L10	50	10	0.15	0.8	2.1
	MTR 3 R0.15 L10	50	10	0.15	1.3	3.1
	MTR 3 R0.15 L15	50	15	0.15	1.3	3.1
	MTR 3 R0.2 L10	50	10	0.2	1.3	3.1
	MTR 3 R0.2 L15	50	15	0.2	1.3	3.1
4.0	MTR 4 R0.15 L10	50	10	0.15	1.7	4.1
	MTR 4 R0.15 L15	50	15	0.15	1.7	4.1
	MTR 4 R0.15 L22	50	20	0.15	1.7	4.1
	MTR 4 R0.2 L10	50	10	0.2	1.7	4.1
	MTR 4 R0.2 L15	50	15	0.2	1.7	4.1
	MTR 4 R0.2 L22	50	20	0.2	1.7	4.1
5.0	MTR 5 R0.1 L15	50	15	0.1	2.2	5.1
	MTR 5 R0.1 L22	50	22	0.1	2.2	5.1
	MTR 5 R0.2 L15	50	15	0.2	2.2	5.1
	MTR 5 R0.2 L22	50	22	0.2	2.2	5.1
6.0	MTR 6 R0.1 L15	50	15	0.1	2.8	6.1
	MTR 6 R0.1 L22	50	22	0.1	2.8	6.1
	MTR 6 R0.2 L15	50	15	0.2	2.8	6.1
	MTR 6 R0.2 L22	50	22	0.2	2.8	6.1
8.0	MTR 7 R0.2 L22	60	22	0.2	3.8	7.1
	MTR 8 R0.2 L15	60	15	0.2	3.8	8.1
	MTR 8 R0.2 L25	60	25	0.2	3.8	8.1
10.0	MTR 10 R0.2 L35	60	35	0.2	4.8	10.1

MNR_R/L_

Для обработки отверстий диаметром от 2 до 10 мм. Внешний подвод СОЖ.

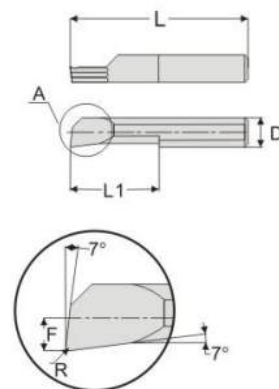

D	Обозначение	L	L1	R	F	Dmin
3.0	MNR 2 R0.15 L5	50	5	0.15	0.8	2.1
	MNR 2 R0.15 L10	50	10	0.15	0.8	2.1
	MNR 3 R0.15 L10	50	10	0.15	1.3	3.1
	MNR 3 R0.15 L15	50	15	0.15	1.3	3.1
	MNR 3 R0.2 L10	50	10	0.2	1.3	3.1
	MNR 3 R0.2 L15	50	15	0.2	1.3	3.1
4.0	MNR 4 R0.15 L10	50	10	0.15	1.7	4.1
	MNR 4 R0.15 L15	50	15	0.15	1.7	4.1
	MNR 4 R0.15 L22	50	20	0.15	1.7	4.1
	MNR 4 R0.2 L10	50	10	0.2	1.7	4.1
	MNR 4 R0.2 L15	50	15	0.2	1.7	4.1
	MNR 4 R0.2 L22	50	20	0.2	1.7	4.1
5.0	MNR 5 R0.1 L15	50	15	0.1	2.2	5.1
	MNR 5 R0.1 L22	50	22	0.1	2.2	5.1
	MNR 5 R0.2 L15	50	15	0.2	2.2	5.1
	MNR 5 R0.2 L22	50	22	0.2	2.2	5.1
6.0	MNR 6 R0.1 L15	50	15	0.1	2.8	6.1
	MNR 6 R0.1 L22	50	22	0.1	2.8	6.1
	MNR 6 R0.2 L15	50	15	0.2	2.8	6.1
	MNR 6 R0.2 L22	50	22	0.2	2.8	6.1
8.0	MNR 7 R0.2 L22	60	22	0.2	3.8	7.1
	MNR 8 R0.2 L15	60	15	0.2	3.8	8.1
	MNR 8 R0.2 L25	60	25	0.2	3.8	8.1
10.0	MNR 10 R0.2 L35	60	35	0.2	4.8	10.1

MGR_B_L_

Для обработки прямоугольных радиальных канавок шириной 1, 1,5, 2 мм в отверстиях диаметром от 4 до 8 мм

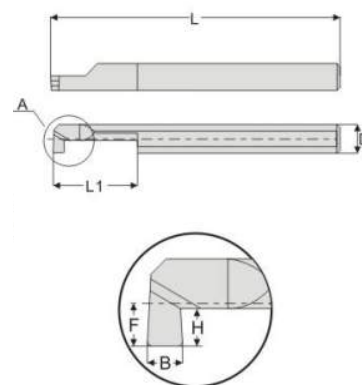

D	Обозначение	L	L1	R	F	Dmin
4.0	MGR 4 B1.0 L10	50	10	0.15	1.8	4.1
	MGR 4 B1.0 L15	50	15	0.15	1.8	4.1
	MGR 4 B1.5 L10	50	10	0.15	1.8	4.1
	MGR 4 B1.5 L15	50	15	0.15	1.8	4.1
5.0	MGR 5 B1.0 L15	50	15	0.15	2.3	5.1
	MGR 5 B1.0 L22	50	22	0.15	2.3	5.1
	MGR 5 B1.5 L15	50	15	0.15	2.3	5.1
	MGR 5 B1.5 L22	50	22	0.15	2.3	5.1
	MGR 5 B2.0 L15	50	15	0.2	2.3	5.1
	MGR 5 B2.0 L22	50	22	0.2	2.3	5.1
6.0	MGR 6 B1.0 L15	50	15	0.15	2.8	6.1
	MGR 6 B1.0 L22	50	22	0.15	2.8	6.1
	MGR 6 B1.5 L15	50	15	0.15	2.8	6.1
	MGR 6 B1.5 L22	50	22	0.15	2.8	6.1
	MGR 6 B2.0 L15	50	15	0.2	2.8	6.1
	MGR 6B2.0 L22	50	22	0.2	2.8	6.1
8.0	MGR 8 B1.0 L25	60	25	0.15	3.8	8.1
	MGR 8 B1.5 L25	60	25	0.15	3.8	8.1
	MGR 8 B2.0 L25	60	25	0.2	3.8	8.1

MIR_A_L_

Для обработки резьб, неполный профиль, 55° и 60° в отверстиях диаметрами от 3 до 6 мм

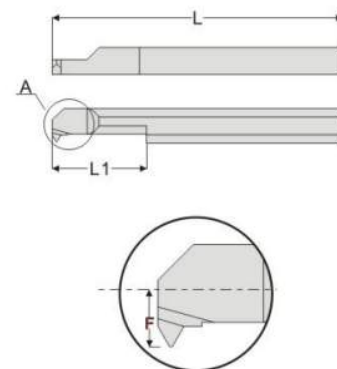

D	Обозначение	L	L1	R	F	Dmin
3.0	MIR 3 A55 L10	50	10	0.07	1.3	3.1
	MIR 3 A55 L15	50	15	0.07	1.3	3.1
	MIR 3 A60 L10	50	10	0.07	1.3	3.1
	MIR 3 A60 L15	50	15	0.07	1.3	3.1
4.0	MIR 4 A55 L10	50	10	0.07	1.8	4.1
	MIR 4 A55 L15	50	15	0.07	1.8	4.1
	MIR 4 A60 L10	50	10	0.07	1.8	4.1
	MIR 4 A60 L15	50	15	0.07	1.8	4.1
5.0	MIR 5 A55 L15	50	15	0.07	2.3	5.1
	MIR 5 A55 L22	50	22	0.07	2.3	5.1
	MIR 5 A60 L15	50	15	0.07	2.3	5.1
	MIR 5 A60 L22	50	22	0.07	2.3	5.1
6.0	MIR 6 A55 L15	50	15	0.07	2.8	6.1
	MIR 6 A55 L22	50	22	0.07	2.8	6.1
	MIR 6 A60 L15	50	15	0.07	2.8	6.1
	MIR 6 A60 L22	50	22	0.07	2.8	6.1

MFR серия

MFR_B_L_

Для обработки прямоугольных торцевых канавок шириной 1, 1.5, 2 мм

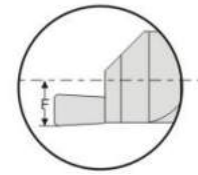
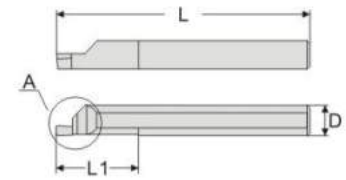

D	Обозначение	L	L1	R	F	Dmin
4.0	MFR 4 B1.0 L10	50	10	0.15	1.8	5.0
	MFR 4 B1.0 L15	50	15	0.15	1.8	5.0
5.0	MFR 5 B1.0 L15	50	15	0.15	2.3	6.0
	MFR 5 B1.0 L22	50	22	0.15	2.3	6.0
	MFR 5 B1.5 L22	50	22	0.15	2.3	6.0
6.0	MFR 6 B1.0 L15	50	15	0.15	2.8	8.0
	MFR 6 B1.0 L22	50	22	0.15	2.8	8.0
	MFR 6 B1.5 L15	50	15	0.15	2.8	8.0
	MFR 6 B1.5 L22	50	22	0.15	2.8	8.0
	MFR 6 B2.0 L15	50	15	0.2	2.8	8.0
	MFR 6 B2.0 L22	50	22	0.2	2.8	8.0

MPR серия

MPR_A_L_

Для обработки отверстий диаметром от 2 до 8 мм. Внешний подвож СОЖ.

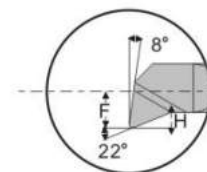
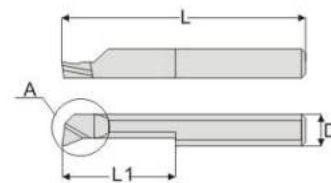
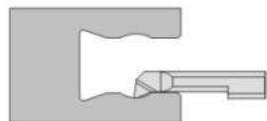

D	Обозначение	L	L1	R	F	Dmin
2.0	MPR 2 R0.15 L10	50	10	0.15	0.8	2.1
	MPR 3 R0.2 L15	50	15	0.2	1.2	3.1
4.0	MPR 4 R0.2 L15	50	15	0.2	1.8	4.1
	MPR 4 R0.2 L22	50	22	0.2	1.8	4.1
5.0	MPR 5 R0.2 L15	50	15	0.2	2.2	5.1
	MPR 5 R0.2 L22	50	22	0.2	2.2	5.1
6.0	MPR 6 R0.2 L15	50	15	0.2	2.7	6.1
	MPR 6 R0.2 L22	50	22	0.2	2.7	6.1
8.0	MPR 8 R0.2 L25	60	25	0.2	2.7	8.1

MXR серия

MXR_B_L_

Для профильной обработки, растачивания и обработки фасок в отверстиях диаметром от 5 до 8 мм. Внешний подвод СОЖ.

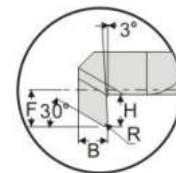
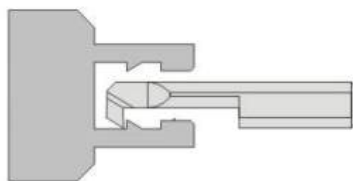
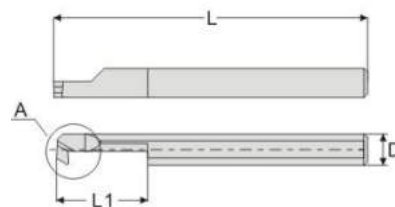

D	Обозначение	L	L1	R	F	Dmin
4.0	MXR 4 B1.0 L10	50	10	0.15	1.8	5.0
	MXR 4 B1.0 L15	50	15	0.15	1.8	5.0
5.0	MXR 5 B1.0 L15	50	15	0.15	2.3	6.0
	MXR 5 B1.0 L22	50	22	0.15	2.3	6.0
	MXR 5 B1.5 L15	50	15	0.15	2.3	6.0
6.0	MXR 5 B1.5 L22	50	22	0.15	2.3	6.0
	MXR 6 B1.0 L15	50	15	0.15	2.8	8.0
	MXR 6 B1.0 L22	50	22	0.15	2.8	8.0
	MXR 6 B1.5 L15	50	15	0.15	2.8	8.0
	MXR 6 B1.5 L22	50	22	0.15	2.8	8.0
	MXR 6 B2.0 L15	50	15	0.2	2.8	8.0
	MXR 6 B2.0 L22	50	22	0.2	2.8	8.0

MQR_R_L_

Для профильной обработки, растачивания в отверстиях диаметром от 4 до 6 мм. Внешний подвод СОЖ.

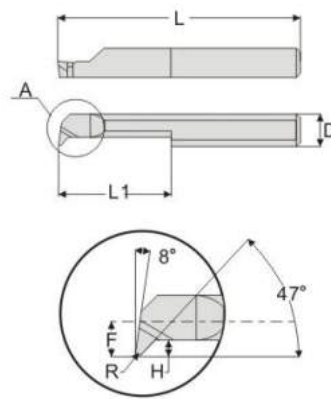
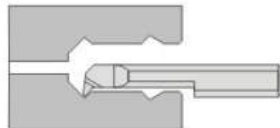

D	Обозначение	L	L1	R	F	Dmin
4.0	MQR 4 R0.2 L10	50	10	0.2	1.8	4.1
	MQR 4 R0.2 L15	50	15	0.2	1.8	4.1
5.0	MQR 5 R0.2 L15	50	15	0.2	2.3	5.1
	MQR 5 R0.2 L22	50	22	0.2	2.3	5.1
6.0	MQR 6 R0.2 L15	50	15	0.2	3.3	6.1
	MQR 6 R0.2 L22	50	22	0.2	2.3	6.1

MZR серия

MZR_R_L_

Для обработки радиусных торцевых канавок с радиусами 0.5, 0.75 и 1 мм в отверстиях диаметром от 5 до 8 мм

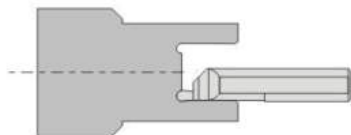
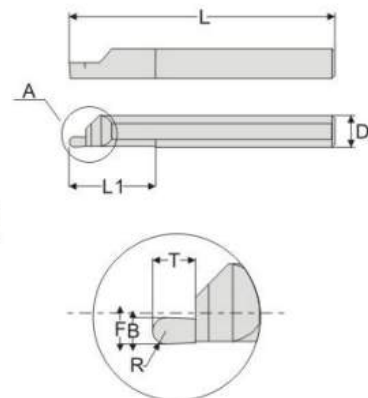

D	Обозначение	L	L1	R	F	Dmin
4.0	MZR 4 R0.5 L10	50	10	0.5	1.8	5.0
	MZR 4 R0.5 L15	50	15	0.5	1.8	5.0
	MZR 4 R0.75 L10	50	10	0.75	1.8	5.0
	MZR 4 R0.75 L15	50	15	0.75	1.8	5.0
5.0	MZR 5 R0.5 L15	50	15	0.5	2.3	6.0
	MZR 5 R0.5 L22	50	22	0.5	2.3	6.0
	MZR 5 R0.75 L15	50	15	0.75	2.3	6.0
	MZR 5 R0.75 L22	50	22	0.75	2.3	6.0
	MZR 5 R1.0 L15	50	15	1.0	2.3	6.0
	MZR 5 R1.0 L22	50	22	1.0	2.3	6.0
6.0	MZR 6 R0.5 L15	50	15	0.5	2.8	8.0
	MZR 6 R0.5 L22	50	22	0.5	2.8	8.0
	MZR 6 R0.75 L15	50	15	0.75	2.8	8.0
	MZR 6 R0.75 L22	50	22	0.75	2.8	8.0
	MZR 6 R1.0 L15	50	15	1.0	2.8	8.0
	MZR 6 R1.0 L22	50	22	1.0	2.8	8.0

МКР серия

МКР_Р_Л_

Для обработки радиусных радиальных канавок с радиусами 0.5, 0.75 и 1 мм в отверстиях диаметром от 5 до 8 мм

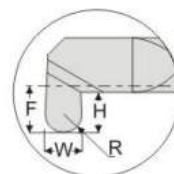
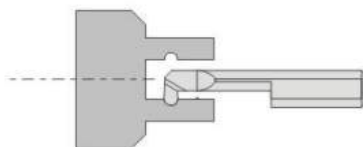
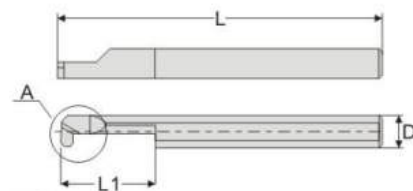

D	Обозначение	L	L1	R	F	Dmin
4.0	MKR 4 R0.5 L10	50	10	0.5	1.8	5.0
	MKR 4 R0.5 L15	50	15	0.5	1.8	5.0
	MKR 4 R0.75 L10	50	10	0.75	1.8	5.0
	MKR 4 R0.75 L15	50	15	0.75	1.8	5.0
5.0	MKR 5 R0.5 L15	50	15	0.5	2.3	6.0
	MKR 5 R0.5 L22	50	22	0.5	2.3	6.0
	MKR 5 R0.75 L15	50	15	0.75	2.3	6.0
	MKR 5 R0.75 L22	50	22	0.75	2.3	6.0
	MKR 5 R1.0 L15	50	15	1.0	2.3	6.0
	MKR 5 R1.0 L22	50	22	1.0	2.3	6.0
6.0	MKR 6 R0.5 L15	50	15	0.5	2.8	8.0
	MKR 6 R0.5 L22	50	22	0.5	2.8	8.0
	MKR 6 R0.75 L15	50	15	0.75	2.8	8.0
	MKR 6 R0.75 L22	50	22	0.75	2.8	8.0
	MKR 6 R1.0 L15	50	15	1.0	2.8	8.0
	MKR 6 R1.0 L22	50	22	1.0	2.8	8.0



Корпусные сверла



Глубина сверления 2xD

2D сверло с хвостовиком WC

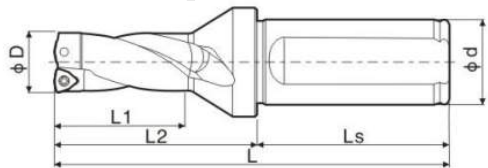

Обозначение	D	L1	L	Ds	Ls	Модель пластины	Винт	Ключ
C20-2D15-33WC03	15	20	33	44	92	WC_030208	M2.5X5	T8
C20-2D15.5-34WC03	15.5		33		93			
C20-2D16-35WC03	16		35		94			
C20-2D16.5-36WC03	16.5		36		95			
C20-2D17-37WC03	17		37		96			
C25-2D17.5-38WC03	17.5	25	38	56	109	WC_030208	M2.5X6	T8
C25-2D18-39WC03	18		39		110			
C25-2D18.5-40WC03	18.5		40		111			
C25-2D19-41WC03	19		41		112			
C25-2D19.5-42WC03	19.5		42		113			
C25-2D20-43WC03	20		43		114			
C25-2D20.5-44WC03	20.5		44		115			
C25-2D21-45WC04	21	25	45	56	116	WC_040208	M2.5X7D	T8
C25-2D21.5-46WC04	21.5		46		117			
C25-2D22-47WC04	22		47		118			
C25-2D22.5-48WC04	22.5		48		119			
C25-2D23-49WC04	23		49		123			
C25-2D23.5-50WC04	23.5		50		124			
C25-2D24-51WC04	24		51		125			
C25-2D24.5-52WC04	24.5		52		126			
C25-2D25-53WC05	25	32	53	60	127	WC_050308	M3X7	T10
C32-2D25.5-54WC05	25.5		54		134			
C32-2D26-55WC05	26		55		135			
C32-2D26.5-56WC05	26.5		56		136			
C32-2D27-57WC05	27		57		137			
C32-2D27.5-58WC05	27.5		58		138			
C32-2D28-59WC05	28		59		139			
C32-2D28.5-60WC05	28.5		60		140			
C32-2D29-62WC05	29		62		143			
C32-2D29.5-63WC05	29.5		63		144			
C32-2D30-64WC05	30	64	148					
C32-2D30.5-65WC05	30.5	65	149					
C32-2D31-66WC06	31	32	66	60	150	WC_06T308	M3.5X8	T15
C32-2D31.5-67WC06	31.5		67		151			
C32-2D32-68WC06	32		68		152			

Глубина сверления 2xD

2D сверло с хвостовиком WC

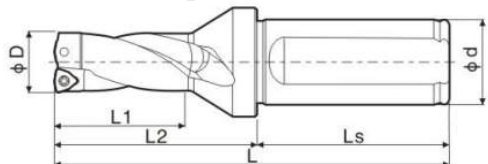

Обозначение	D	L1	L	Ds	Ls	Модель пластины	Винт	Ключ
C32-2D32.5-69WC06	32.5	32	69	60	153	WC_06T308	M3.5X8	T15
C32-2D33-70WC06	33		70		154			
C32-2D33.5-71WC06	33.5		71		155			
C32-2D34-72WC06	34		72		156			
C32-2D34.5-73WC06	34.5		73		157			
C32-2D35-74WC06	35		74		158			
C32-2D35.5-75WC06	35.5		75		159			
C32-2D36-76WC06	36		76		160			
C32-2D36.5-77WC06	36.5		77		161			
C32-2D37-79WC06	37		79		169			
C32-2D37.5-80WC06	37.5		80		170			
C32-2D38-81WC06	38		81		171			
C32-2D38.5-82WC06	38.5		82		172			
C32-2D39-83WC06	39		83		173			
C32-2D39.5-84WC06	39.5	84	174					
C40-2D40-85WC08	40	40	85	70	185	WC_080412	M4X10	T15
C40-2D41-87WC08	41		87		187			
C40-2D42-89WC08	42		89		189			
C40-2D43-91WC08	43		91		191			
C40-2D44-93WC08	44		93		193			
C40-2D45-95WC08	45		95		195			
C40-2D46-97WC08	46		97		197			
C40-2D47-99WC08	47		99		199			
C40-2D48-101WC08	48		101		201			
C40-2D49-103WC08	49		103		203			
C40-2D50-105WC08	50		105		205			
C40-2D51-107WC08	51		107		207			
C40-2D52-109WC08	52		109		209			
C40-2D53-111WC08	53		111		211			
C40-2D54-113WC08	54	113	213					
C40-2D55-115WC08	55	115	215					
C40-2D56-120WC08	56	120	222					
C40-2D57-122WC08	57	122	224					
C10-2D58-124WC08	58	124	226					
C40-2D59-126WC08	59	126	228					
C40-2D60-128WC08	60	128	230					

3D сверло с хвостовиком WC

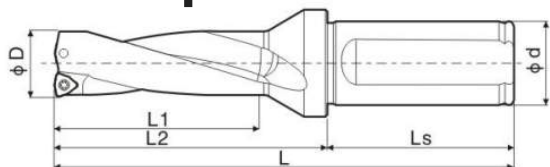

Обозначение	D	L1	L	Ds	Ls	Модель пластины	Винт	Ключ
C20-3D15-48WC03	15	20	48	44	107	WC_030208	M2.5X5	T8
C20-3D15.5-50WC03	15.5		50		109			
C20-3D16-51WC03	16		51		110			
C20-3D16.5-53WC03	16.5		53		112			
C20-3D17-54WC03	17		54		113			
C25-3D17.5-56WC03	17.5	25	56	56	127	WC_030208	M2.5X6	T8
C25-3D18-57WC03	18		57		128			
C25-3D18.5-59WC03	18.5		59		130			
C25-3D19-60WC03	19		60		131			
C25-3D19.5-62WC03	19.5		62		133			
C25-3D20-63WC03	20		63		134			
C25-3D20.5-65WC03	20.5		65		136			
C25-3D21-66WC04	21	25	66	56	137	WC_040208	M2.5X7D	T8
C25-3D21.5-68WC04	21.5		68		139			
C25-3D22-69WC04	22		69		140			
C25-3D22.5-71WC04	22.5		71		142			
C25-3D23-72WC04	23		72		146			
C25-3D23.5-74WC04	23.5		74		148			
C25-3D24-75WC04	24		75		149			
C25-3D24.5-77WC04	24.5		77		151			
C25-3D25-78WC05	25	32	78	60	152	WC_050308	M3X7	T10
C32-3D25.5-80WC05	25.5		80		160			
C32-3D26-81WC05	26		81		161			
C32-3D26.5-83WC05	26.5		83		163			
C32-3D27-84WC05	27		84		164			
C32-3D27.5-86WC05	27.5		86		166			
C32-3D28-87WC05	28		87		167			
C32-3D28.5-89WC05	28.5		89		169			
C32-3D29-91WC05	29		91		172			
C32-3D29.5-93WC05	29.5		93		174			
C32-3D30-94WC05	30	94	178					
C32-3D30.5-96WC05	30.5	96	180					
C32-3D31-97WC06	31	32	97	60	181	WC_06T308	M3.5X8	T15
C32-3D31.5-99WC06	31.5		99		183			
C32-3D32-100WC06	32		100		184			

Глубина сверления 3xD

3D сверло с хвостовиком WC

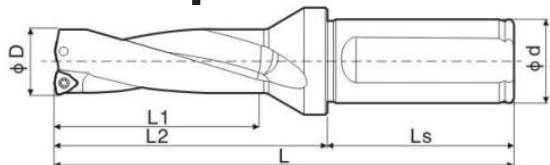

Обозначение	D	L1	L	Ds	Ls	Модель пластины	Винт	Ключ
C32-3D32.5-102WC06	32.5	32	102	60	186	WC_06T308	M3.5X8	T15
C32-3D33-103WC06	33		103		187			
C32-3D33.5-105WC06	33.5		105		189			
C32-3D34-106WC06	34		106		190			
C32-3D34.5-108WC06	34.5		108		192			
C32-3D35-109WC06	35		109		193			
C32-3D35.5-111WC06	35.5		111		195			
C32-3D36-112WC06	36		112		196			
C32-3D36.5-114WC06	36.5		114		198			
C32-3D37-116WC06	37		116		206			
C32-3D37.5-118WC06	37.5		118		208			
C32-3D38-119WC06	38		119		209			
C32-3D38.5-121WC06	38.5		121		211			
C32-3D39-122WC06	39		122		212			
C32-3D39.5-124WC06	39.5	124	214					
C40-3D40-125WC08	40	40	125	70	225	WC_080412	M4X10	T15
C40-3D41-128WC08	41		128		228			
C40-3D42-131WC08	42		131		231			
C40-3D43-134WC08	43		134		234			
C40-3D44-137WC08	44		137		237			
C40-3D45-140WC08	45		140		240			
C40-3D46-143WC08	46		143		243			
C40-3D47-146WC08	47		146		246			
C40-3D48-149WC08	48		149		249			
C40-3D49-152WC08	49		152		252			
C40-3D50-155WC08	50		155		255			
C40-3D51-158WC08	51		158		258			
C40-3D52-161WC08	52		161		261			
C40-3D53-164WC08	53		164		264			
C40-3D54-167WC08	54	167	267					
C40-3D55-170WC08	55	170	270					
C40-3D56-176WC08	56	176	278					
C40-3D57-179WC08	57	179	281					
C10-3D58-182WC08	58	182	284					
C40-3D59-185WC08	59	185	287					
C40-3D60-188WC08	60	188	290					

Глубина сверления 4xD

4D сверло с хвостовиком WC

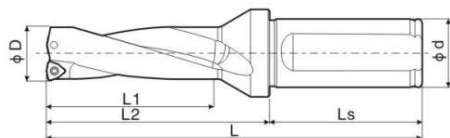

Обозначение	D	L1	L	Ds	Ls	Модель пластины	Винт	Ключ
C20-4D15-63WC03	15	20	63	44	122	WC_030208	M2.5X5	T8
C20-4D15.5-65WC03	15.5		65		124			
C20-4D16-67WC03	16		67		126			
C20-4D16.5-69WC03	16.5		69		128			
C20-4D17-71WC03	17		71		130			
C25-4D17.5-73WC03	17.5	25	73	56	144	WC_030208	M2.5X6	T8
C25-4D18-75WC03	18		75		146			
C25-4D18.5-77WC03	18.5		77		148			
C25-4D19-79WC03	19		79		150			
C25-4D19.5-81WC03	19.5		81		152			
C25-4D20-83WC03	20		83		154			
C25-4D20.5-85WC03	20.5		85		156			
C25-4D21-87WC04	21	25	87	56	158	WC_040208	M2.5X7D	T8
C25-4D21.5-89WC04	21.5		89		160			
C25-4D22-91WC04	22		91		162			
C25-4D22.5-93WC04	22.5		93		164			
C25-4D23-95WC04	23		95		169			
C25-4D23.5-97WC04	23.5		97		171			
C25-4D24-99WC04	24		99		173			
C25-4D24.5-101WC04	24.5		101		175			
C25-4D25-103WC05	25	32	103	60	177	WC_050308	M3X7	T10
C32-4D25.5-105WC05	25.5		105		185			
C32-4D26-107WC05	26		107		187			
C32-4D26.5-109WC05	26.5		109		189			
C32-4D27-111WC05	27		111		191			
C32-4D27.5-113WC05	27.5		113		193			
C32-4D28-115WC05	28		115		195			
C32-4D28.5-117WC05	28.5		117		197			
C32-4D29-120WC05	29		120		201			
C32-4D29.5-122WC05	29.5		122		203			
C32-4D30-124WC05	30	124	208					
C32-4D30.5-126WC05	30.5	126	210					
C32-4D31-128WC06	31	32	128	60	212	WC_06T308	M3.5X8	T15
C32-4D31.5-130WC06	31.5		130		214			
C32-4D32-132WC06	32		132		216			

Глубина сверления 4xD

4D сверло с хвостовиком WC

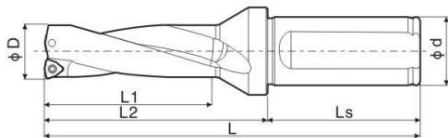

Обозначение	D	L1	L	Ds	Ls	Модель пластины	Винт	Ключ
C32-4D32.5-134WC06	32.5	32	140	60	218	WC_06T308	M3.5X8	T15
C32-4D33-136WC06	33		136		220			
C32-4D33.5-138WC06	33.5		138		222			
C32-4D34-140WC06	34		140		224			
C32-4D34.5-142WC06	34.5		142		226			
C32-4D35-144WC06	35		144		228			
C32-4D35.5-146WC06	35.5		146		230			
C32-4D36-148WC06	36		148		232			
C32-4D36.5-150WC06	36.5		150		236			
C32-4D37-153WC06	37		153		243			
C32-4D37.5-155WC06	37.5		155		245			
C32-4D38-157WC06	38		157		247			
C32-4D38.5-159WC06	38.5		159		249			
C32-4D39-161WC06	39		161		251			
C32-4D39.5-163WC06	39.5	163	253					
C40-4D40-165WC08	40	40	165	70	265	WC_080412	M4X10	T15
C40-4D41-169WC08	41		169		269			
C40-4D42-173WC08	42		173		273			
C40-4D43-177WC08	43		177		277			
C40-4D44-181WC08	44		181		281			
C40-4D45-185WC08	45		185		285			
C40-4D46-189WC08	46		189		289			
C40-4D47-193WC08	47		193		293			
C40-4D48-197WC08	48		197		297			
C40-4D49-201WC08	49		201		301			
C40-4D50-205WC08	50		205		305			
C40-4D51-209WC08	51		209		309			
C40-4D52-213WC08	52		213		313			
C40-4D53-217WC08	53		217		317			
C40-4D54-221WC08	54	221	321					
C40-4D55-225WC08	55	225	325					
C40-4D56-232WC08	56	232	334					
C40-4D57-236WC08	57	236	338					
C10-4D58-240WC08	58	240	342					
C40-4D59-244WC08	59	244	346					
C40-4D60-248WC08	60	248	350					



Глубина сверления 5xD

5D сверло с хвостовиком WC

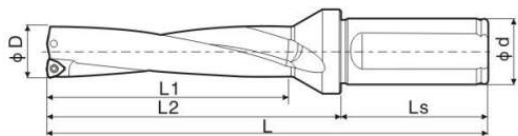

Обозначение	D	L1	L	Ds	Ls	Модель пластины	Винт	Ключ
C20-5D16-83WC03	16	20	83	44	142	WC_030208	M2.5X5	T8
C20-5D16.5-86WC03	16.5		86		145			
C20-5D17-88WC03	17		88		147			
C25-5D17.5-91WC03	17.5	25	91	56	150	WC_030208	M2.5X6	T8
C25-5D18-93WC03	18		93		152			
C25-5D18.5-96WC03	18.5		96		155			
C25-5D19-98WC03	19		98		157			
C25-5D19.5-101WC03	19.5		101		160			
C25-5D20-103WC03	20		103		162			
C25-5D20.5-106WC03	20.5	106	165					
C25-5D21-108WC04	21	25	108	56	167	WC_040208	M2.5X7D	T8
C25-5D21.5-111WC04	21.5		111		170			
C25-5D22-113WC04	22		113		172			
C25-5D22.5-116WC04	22.5		116		175			
C25-5D23-118WC04	23		118		180			
C25-5D23.5-121WC04	23.5		121		183			
C25-5D24-123WC04	24		123		185			
C25-5D24.5-126WC04	24.5		126		188			
C25-5D25-128WC04	25		128		190			
C32-5D25.5-131WC05	25.5		32		131			
C32-5D26-133WC05	26	133		216				
C32-5D26.5-136WC05	26.5	136		217				
C32-5D27-138WC05	27	138		218				
C32-5D27.5-141WC05	27.5	141		221				
C32-5D28-143WC05	28	143		223				
C32-5D28.5-146WC05	28.5	146		226				
C32-5D29-149WC05	29	149		230				
C32-5D29.5-151WC05	29.5	151		233				
C32-5D30-154WC05	30	154		238				
C32-5D30.5-157WC05	30.5	157	241					
C32-5D31-159WC06	31	32	159	60	243	WC_06T308	M3.5X8	T15
C32-5D31.5-162WC06	31.5		162		245			
C32-5D32-164WC06	32		164		248			
C32-5D32.5-167WC06	32.5		167		251			
C32-5D33-169WC06	33		169		253			
C32-5D33.5-172WC06	33.5		172		255			
C32-5D34-174WC06	34		174		258			

Глубина сверления 5xD

5D сверло с хвостовиком WC

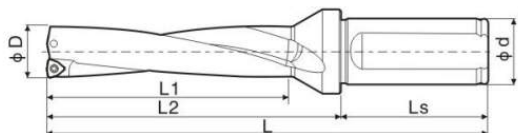

Обозначение	D	L1	L	Ds	Ls	Модель пластины	Винт	Ключ
C32-5D34.5-177WC06	34.5	32	177	60	261	WC_06T308	M3.5X8	T15
C32-5D35-179WC06	35		179		263			
C32-5D35.5-182WC06	35.5		182		265			
C32-5D36-184WC06	36		184		268			
C32-5D36.5-187WC06	36.5		187		271			
C32-5D37-190WC06	37		190		280			
C32-5D37.5-193WC06	37.5		193		283			
C32-5D38-195WC06	38		195		285			
C32-5D38.5-198WC06	38.5		198		288			
C32-5D39-200WC06	39		200		290			
C32-5D39.5-203WC06	39.5		203		293			
C40-5D40-205WC06	40	40	205	70	305	WC_080412	M4X10	T15
C40-5D41-210WC06	41		210		310			
C40-5D42-220WC08	42		220		315			
C40-5D43-225WC08	43		225		320			
C40-5D44-230WC08	44		230		325			
C40-5D45-235WC08	45		235		330			
C40-5D46-240WC08	46		240		335			
C40-5D47-245WC08	47		245		340			
C40-5D48-250WC08	48		250		345			
C40-5D49-255WC08	49		255		350			
C40-5D50-260WC08	50		260		355			
C40-5D51-265WC08	51	265	360					
C40-5D52-270WC08	52	270	365					
C40-5D53-275WC08	53	275	370					
C40-5D54-280WC08	54	280	375					
C40-5D55-285WC08	55	285	380					
C40-5D56-290WC08	56	290	385					
C40-5D57-295WC08	57	295	390					
C40-5D58-300WC08	58	300	395					
C40-5D59-305WC08	59	305	400					
C40-5D60-310WC08	60	310	405					



2D сверло с хвостовиком SP

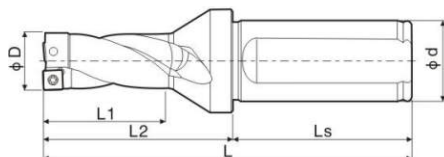

Обозначение	D	L1	L	Ds	Ls	Модель пластины	Винт	Ключ
C20-2D13-29SP05	13	20	29	44	88	SP_050204	M2X4	T6
C20-2D13.5-30SP05	13.5		30		89			
C20-2D14-31SP05	14		31		90			
C20-2D14.5-32SP05	14.5		32		91			
C20-2D15-33SP05	15		33		92			
C20-2D15.5-34SP06	15.5	25	34	44	93	SP_060204	M2.2X5	T7
C20-2D16-35SP06	16		35		94			
C20-2D16.5-36SP06	16.5		36		95			
C20-2D17-37SP06	17		37		96			
C25-2D17.5-38SP06	17.5	25	38	56	109	SP_060204	M2.2X5	T7
C25-2D18-39SP06	18		39		110			
C25-2D18.5-40SP06	18.5		40		111			
C25-2D19-41SP06	19		41		112			
C25-2D19.5-42SP06	19.5		42		113			
C25-2D20-43SP06	20		43		114			
C25-2D20.5-44SP06	20.5		44		115			
C25-2D21-45SP06	21		45		116			
C25-2D21.5-46SP06	21.5		46		117			
C25-2D22-47SP07	22		25		47			
C25-2D22.5-48SP07	22.5	48		119				
C25-2D23-49SP07	23	49		123				
C25-2D23.5-50SP07	23.5	50		124				
C25-2D24-51SP07	24	51		125				
C25-2D24.5-52SP07	24.5	52		126				
C25-2D25-53SP07	25	53		127				
C32-2D25.5-54SP07	25.5	32	54	60	134	SP_090408	M3.5X8	T15
C32-2D26-55SP07	26		55		135			
C32-2D26.5-56SP07	26.5		56		136			
C32-2D27-57SP07	27		57		137			
C32-2D27.5-58SP07	27.5		58		138			
C32-2D28-59SP09	28	32	59	60	139	SP_090408	M3.5X8	T15
C32-2D28.5-60SP09	28.5		60		140			
C32-2D29-62SP09	29		62		143			
C32-2D29.5-63SP09	29.5		63		144			
C32-2D30-64SP09	30		64		148			
C32-2D30.5-65SP09	30.5		65		149			
C32-2D31-66SP09	31		66		150			

Глубина сверления 2xD

2D сверло с хвостовиком SP

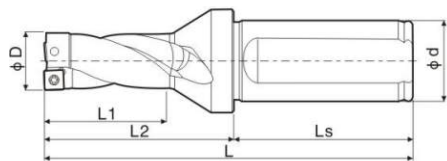

Обозначение	D	L1	L	Ds	Ls	Модель пластины	Винт	Ключ
C32-2D31.5-67SP09	31.5	32	67	60	151	SP_090408	M3.5X8	T15
C32-2D32-68SP09	32		68		152			
C32-2D32.5-69SP09	32.5		69		153			
C32-2D33-70SP09	33		70		154			
C32-2D33.5-71SP09	33.5		71		155			
C32-2D34-72SP11	34	32	72	60	156	SP_110408	M4X10	T15
C32-2D34.5-73SP11	34.5		73		157			
C32-2D35-74SP11	35		74		158			
C32-2D35.5-75SP11	35.5		75		159			
C32-2D36-76SP11	36		76		160			
C32-2D36.5-77SP11	36.5		77		161			
C32-2D37-79SP11	37		79		169			
C32-2D37.5-80SP11	37.5		80		170			
C32-2D38-81SP11	38		81		171			
C32-2D38.5-82SP11	38.5		82		172			
C32-2D39-83SP11	39	83	173					
C32-2D39.5-84SP11	39.5	84	174					
C40-2D40-85SP11	40	40	85	70	185	SP_140512	M5X11	T20
C40-2D41-87SP11	41		87		187			
C40-2D42-89SP14	42		89		189			
C40-2D43-91SP14	43		91		191			
C40-2D44-93SP14	44		93		193			
C40-2D45-95SP14	45		95		195			
C40-2D46-97SP14	46		97		197			
C40-2D47-99SP14	47		99		199			
C40-2D48-101SP14	48		101		201			
C40-2D49-103SP14	49		103		203			
C40-2D50-105SP14	50	105	205					
C40-2D51-107SP09	51	40	107	70	207	SP_090408	M3.5X8	T15
C40-2D52-109SP09	52		109		209			
C40-2D53-111SP09	53		111		211			
C40-2D54-113SP09	54		113		213			
C40-2D55-115SP09	55		115		215			
C40-2D56-120SP09	56		120		222			
C40-2D57-122SP09	57		122		224			
C40-2D58-124SP09	58		124		226			
C40-2D59-126SP09	59		126		228			
C40-2D60-128SP09	60		128		230			



3D сверло с хвостовиком SP

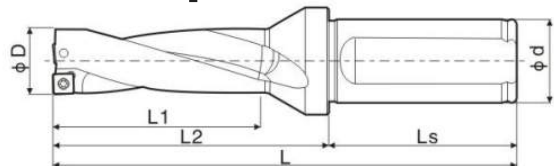

Обозначение	D	L1	L	Ds	Ls	Модель пластины	Винт	Ключ
C20-3D13-42SP05	13	20	42	44	101	SP_050204	M2X4	T6
C20-3D13.5-44SP05	13.5		44		103			
C20-3D14-45SP05	14		45		104			
C20-3D14.5-47SP05	14.5		47		106			
C20-3D15-48SP05	15		48		107			
C20-3D15.5-50SP06	15.5	25	50	44	109			
C20-3D16-51SP06	16		51		110			
C20-3D16.5-53SP06	16.5		53		112			
C20-3D17-54SP06	17		54		113			
C25-3D17.5-56SP06	17.5	25	56	56	127	SP_060204	M2.2X5	T7
C25-3D18-57SP06	18		57		128			
C25-3D18.5-59SP06	18.5		59		130			
C25-3D19-60SP06	19		60		131			
C25-3D19.5-62SP06	19.5		62		133			
C25-3D20-63SP06	20		63		134			
C25-3D20.5-65SP06	20.5		65		136			
C25-3D21-66SP06	21		66		137			
C25-3D21.5-68SP06	21.5		68		139			
C25-3D22-69SP07	22	25	69	56	140	SP_07T308	M2.5X6	T8
C25-3D22.5-71SP07	22.5		71		142			
C25-3D23-72SP07	23		72		146			
C25-3D23.5-74SP07	23.5		74		148			
C25-3D24-75SP07	24		75		149			
C25-3D24.5-77SP07	24.5		77		151			
C25-3D25-78SP07	25		78		152			
C32-3D25.5-80SP07	25.5	32	80	60	160			
C32-3D26-81SP07	26		81		161			
C32-3D26.5-83SP07	26.5		83		163			
C32-3D27-84SP07	27		84		164			
C32-3D27.5-86SP07	27.5		86		166			
C32-3D28-87SP09	28	32	87	60	167	SP_090408	M3.5X8	T15
C32-3D28.5-89SP09	28.5		89		169			
C32-3D29-91SP09	29		91		172			
C32-3D29.5-93SP09	29.5		93		174			
C32-3D30-94SP09	30		94		178			
C32-3D30.5-96SP09	30.5		96		180			
C32-3D31-97SP09	31		97		181			
C32-3D31.5-99SP09	31.5		99		183			

3D сверло с хвостовиком SP

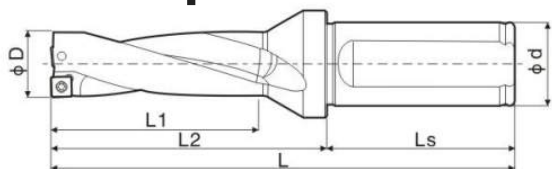

Обозначение	D	L1	L	Ds	Ls	Модель пластины	Винт	Ключ
C32-3D32-100SP09	32	32	100	60	184	SP_090408	M3.5X8	T15
C32-3D32.5-102SP09	32.5		102		186			
C32-3D33-103SP09	33		103		187			
C32-3D33.5-105SP09	33.5		105		189			
C32-3D34-106SP11	34	32	106	60	190	SP_110408	M4X10	T15
C32-3D34.5-108SP11	34.5		108		192			
C32-3D35-109SP11	35		109		193			
C32-3D35.5-111SP11	35.5		111		195			
C32-3D36-112SP11	36		112		196			
C32-3D36.5-114SP11	36.5		114		198			
C32-3D37-116SP11	37		116		206			
C32-3D37.5-118SP11	37.5		118		207			
C32-3D38-119SP11	38		119		209			
C32-3D38.5-121SP11	38.5		121		211			
C32-3D39-122SP11	39	122	212					
C32-3D39.5-124SP11	39.5	124	214					
C40-3D40-125SP11	40	40	125	70	225	SP_140512	M5X11	T20
C40-3D41-128SP11	41		128		228			
C40-3D42-131SP14	42		131		231			
C40-3D43-134SP14	43		134		234			
C40-3D44-137SP14	44		137		237			
C40-3D45-140SP14	45		140		240			
C40-3D46-143SP14	46		143		243			
C40-3D47-146SP14	47		146		246			
C40-3D48-149SP14	48		149		249			
C40-3D49-152SP14	49		152		252			
C40-3D50-155SP14	50	155	255					
C40-3D51-158SP09	51	40	158	70	258	SP_090408	M3.5X8	T15
C40-3D52-161SP09	52		161		261			
C40-3D53-164SP09	53		164		264			
C40-3D54-167SP09	54		167		267			
C40-3D55-170SP09	55		170		270			
C40-3D56-173SP09	56		176		278			
C40-3D57-179SP09	57		179		281			
C40-3D58-182SP09	58		182		284			
C40-3D59-185SP09	59		185		287			
C40-3D60-188SP09	60		188		290			

Глубина сверления 4xD

4D сверло с хвостовиком SP

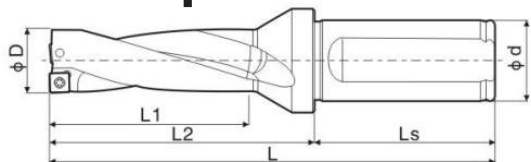

Обозначение	D	L1	L	Ds	Ls	Модель пластины	Винт	Ключ					
C20-4D13-55SP05	13	20	55	44	114	SP_050204	M2X4	T6					
C20-4D13.5-57SP05	13.5		57		116								
C20-4D14-59SP05	14		59		118								
C20-4D14.5-61SP05	14.5		61		120								
C20-4D15-63SP05	15		63		122								
C20-4D15.5-65SP06	15.5	25	65	44	124	SP_060204	M2.2X5	T7					
C20-4D16-67SP06	16		67		126								
C20-4D16.5-69SP06	16.5		69		128								
C20-4D17-71SP06	17		71		130								
C25-4D17.5-73SP06	17.5	25	73	56	144	SP_07T308	M2.5X6	T8					
C25-4D18-75SP06	18		75		146								
C25-4D18.5-77SP06	18.5		77		148								
C25-4D19-79SP06	19		79		150								
C25-4D19.5-81SP06	19.5		81		152								
C25-4D20-83SP06	20		83		154								
C25-4D20.5-85SP06	20.5		85		156								
C25-4D21-87SP06	21		87		158								
C25-4D21.5-89SP06	21.5		89		160								
C25-4D22-91SP07	22		25		91				56	162	SP_090408	M3.5X8	T15
C25-4D22.5-93SP07	22.5	93		164									
C25-4D23-95SP07	23	95		169									
C25-4D23.5-97SP07	23.5	97		171									
C25-4D24-99SP07	24	99		183									
C25-4D24.5-101SP07	24.5	32	101	60	175	SP_090408	M3.5X8	T15					
C25-4D25-103SP07	25		103		177								
C32-4D25.5-105SP07	25.5		105		185								
C32-4D26-107SP07	26		107		187								
C32-4D26.5-109SP07	26.5		109		189								
C32-4D27-111SP07	27		111		191								
C32-4D27.5-113SP07	27.5		113		193								
C32-4D28-115SP09	28		32		115				60	195	SP_090408	M3.5X8	T15
C32-4D28.5-117SP09	28.5				117					197			
C32-4D29-120SP09	29				120					201			
C32-4D29.5-122SP09	29.5	122		203									
C32-4D30-124SP09	30	124		208									
C32-4D30.5-126SP09	30.5	126		210									
C32-4D31-128SP09	31	128		212									
C32-4D31.5-130SP09	31.5	130		214									

Глубина сверления 4xD

4D сверло с хвостовиком SP

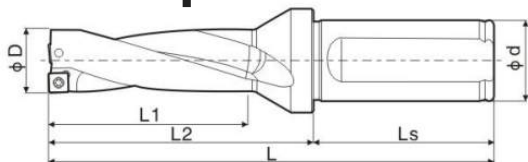

Обозначение	D	L1	L	Ds	Ls	Модель пластины	Винт	Ключ
C32-4D32-132SP09	32	32	132	60	216	SP_090408	M3.5X8	T15
C32-4D32.5-134SP09	32.5		134		218			
C32-4D33-136SP09	33		136		220			
C32-4D33.5-138SP09	33.5		138		222			
C32-4D34-140SP11	34	32	140	60	224	SP_110408	M4X10	T15
C32-4D34.5-142SP11	34.5		142		226			
C32-4D35-144SP11	35		144		228			
C32-4D35.5-146SP11	35.5		146		230			
C32-4D36-148SP11	36		148		232			
C32-4D36.5-150SP11	36.5		150		234			
C32-4D37-152SP11	37		152		243			
C32-4D37.5-155SP11	37.5		155		245			
C32-4D38-157SP11	38		157		247			
C32-4D38.5-159SP11	38.5		159		249			
C32-4D39-161SP11	39		161		251			
C32-4D39.5-163SP11	39.5		163		253			
C40-4D40-165SP11	40	40	165	70	265	SP_140512	M5X11	T20
C40-4D41-169SP11	41		169		269			
C40-4D42-173SP14	42		173		273			
C40-4D43-177SP14	43		177		277			
C40-4D44-181SP14	44		181		281			
C40-4D45-185SP14	45		185		285			
C40-4D46-189SP14	46		189		289			
C40-4D47-193SP14	47		193		293			
C40-4D48-197SP14	48		197		297			
C40-4D49-201SP14	49		201		301			
C40-4D50-205SP14	50	205	305					
C40-4D51-209SP09	51	40	209	70	309	SP_090408	M3.5X8	T15
C40-4D52-213SP09	52		213		313			
C40-4D53-217SP09	53		217		317			
C40-4D54-221SP09	54		221		321			
C40-4D55-225SP09	55		225		325			
C40-4D56-232SP09	56		232		334			
C40-4D57-236SP09	57		236		338			
C40-4D58-240SP09	58		240		342			
C40-4D59-244SP09	59		244		346			
C40-4D60-248SP09	60		248		350			



Глубина сверления 5xD

5D сверло с хвостовиком SP

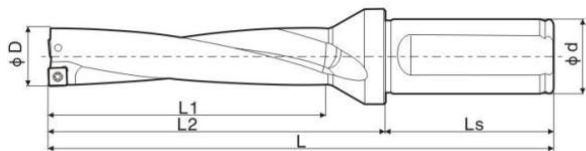

Обозначение	D	L1	L	Ds	Ls	Модель пластины	Винт	Ключ			
C20-5D16-83SP06	16	20	83	44	142	SP_060204	M2.2X5	T7			
C20-5D16.5-86SP06	16.5		86		145						
C20-5D17-88SP06	17		88		147						
C20-5D17.5-91SP06	17.5	25	91	56	162						
C25-5D18-93SP06	18		93		164						
C25-5D18.5-96SP06	18.5		96		167						
C25-5D19-98SP06	19		98		169						
C25-5D19.5-101SP06	19.5		101		172						
C25-5D20-103SP06	20		103		174						
C25-5D20.5-106SP06	20.5	25	106	56	177				SP_07T308	M2.5X6	T8
C25-5D21-108SP06	21		108		179						
C25-5D21.5-111SP06	21.5		111		182						
C25-5D22-113SP07	22		113		184						
C25-5D22.5-116SP07	22.5		116		187						
C25-5D23-118SP07	23		118		192						
C25-5D23.5-121SP07	23.5		121		195						
C25-5D24-123SP07	24	25	123	56	197						
C25-5D24.5-126SP07	24.5		126		200						
C25-5D25-128SP07	25		128		202						
C32-5D25.5-130SP07	25.5		130		213						
C32-5D26-133SP07	26		133		216						
C32-5D26.5-136SP07	26.5	25	136	56	218	SP_090408	M3.5X8	T15			
C32-5D27-138SP07	27		138		219						
C32-5D27.5-141SP07	27.5		141		221						
C32-5D28-143SP09	28	32	143	60	223						
C32-5D28.5-146SP09	28.5		146		226						
C32-5D29-149SP09	29		149		230						
C32-5D29.5-151SP09	29.5		151		233						
C32-5D30-154SP09	30		154		238						
C32-5D30.5-157SP09	30.5		157		241						
C32-5D31-159SP09	31	32	159	60	243	SP_090408	M3.5X8	T15			
C32-5D31.5-162SP09	31.5		162		245						
C32-5D32-164SP09	32		164		248						
C32-5D32.5-167SP09	32.5		167		251						
C32-5D33-169SP09	33		169		253						
C32-5D33.5-172SP09	33.5	172	255								

Глубина сверления 5xD

5D сверло с хвостовиком SP

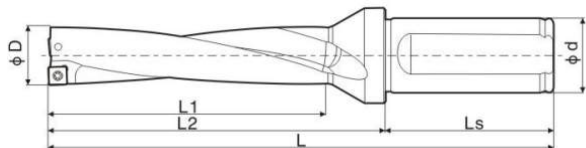

Обозначение	D	L1	L	Ds	Ls	Модель пластины	Винт	Ключ					
C32-5D34-174SP11	34	32	174	60	258	SP_110408	M4X10	T15					
C32-5D34.5-177SP11	34.5		177		261								
C32-5D35-179SP11	35		179		263								
C32-5D35.5-182SP11	35.5		182		265								
C32-5D36-184SP11	36		184		268								
C32-5D36.5-187SP11	36.5		187		271								
C32-5D37-190SP11	37		190		280								
C32-5D37.5-193SP11	37.5		193		283								
C32-5D38-195SP11	38		195		285								
C32-5D38.5-198SP11	38.5		198		288								
C32-5D39-200SP11	39		200		290								
C32-5D39.5-203SP11	39.5		203		293								
C40-5D40-205SP11	40		40		205				70	305	SP_140512	M5X11	T20
C40-5D41-210SP11	41	210		310									
C40-5D42-215SP14	42	215		315									
C40-5D43-220SP14	43	220		320									
C40-5D44-225SP14	44	225		325									
C40-5D45-230SP14	45	230		330									
C40-5D46-235SP14	46	235		335									
C40-5D47-240SP14	47	240		340									
C40-5D48-245SP14	48	245		345									
C40-5D49-250SP14	49	250		350									
C40-5D50-255SP14	50	255		355									
C40-5D51-260SP09	51	40		260	70	360	SP_090408	M3.5X8		T15			
C40-5D52-265SP09	52			265		365							
C40-5D53-270SP09	53		270	370									
C40-5D54-275SP09	54		275	375									
C40-5D55-280SP09	55		280	380									
C40-5D56-285SP09	56		285	385									
C40-5D57-290SP09	57		290	390									
C40-5D58-295SP09	58		295	395									
C40-5D59-300SP09	59		300	400									
C40-5D60-305SP09	60		305	400									

2.25D

Многофункциональные сверла U-серии, 2.25D

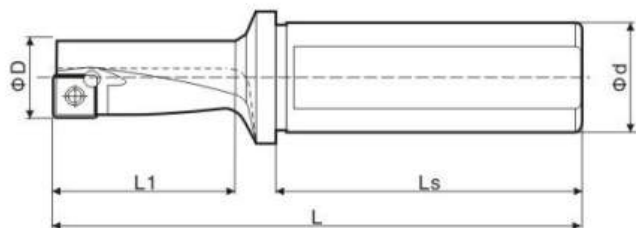

Обозначение	D	L1	L	Ds	Ls		Винт	Ключ
TCAP 08R/L-2.25DN	8	12	18	42	66	XCMT040104	M1.8X4	T6
TCAP 10R/L-2.25DN	10	12	22.5	42	70	XCMT050204	M2.0X5	T6
TCAP 12R/L-2.25DN	12	16	27	45	78	XCMT060204	M2.2X5	T6
TCAP 14R/L-2.25DN	14	16	31.5	45	82	XCMT070304	M2.5X6	T8
TCAP 16R/L-2.25DN	16	20	36	50	92	XCMT080304	M3.0X8	T10

3.25D

Многофункциональные сверла U-серии, 3.25D

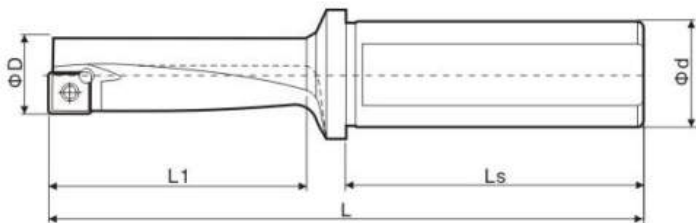

Обозначение	D	L1	L	Ds	Ls	Модель пластины	Винт	Ключ
TCAP 08R/L-3.25DN	8	12	26	42	76	XCMT040104	M1.8X4	T6
TCAP 10R/L-3.25DN	10	12	32.5	42	80	XCMT050204	M2.0X5	T6
TCAP 12R/L-3.25DN	12	16	39	45	90	XCMT060204	M2.2X5	T6
TCAP 14R/L-3.25DN	14	16	45.5	45	97	XCMT070304	M2.5X6	T8
TCAP 16R/L-3.25DN	16	20	52	50	108	XCMT080304	M3.0X8	T10

2.5D

Многофункциональные сверла U-серии, 2.5D

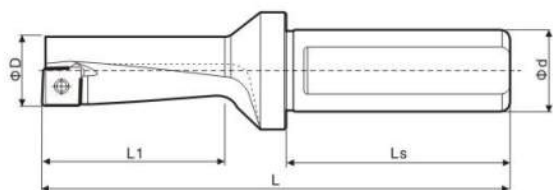

Обозначение	D	L1	L	Ds	Ls	Модель пластины	Винт	Ключ
SF-08R-2.5D-C16	8	16	20	42	72	QCMT040104	M1.8X4	T6
SF-10R-2.5D-C16	10	16	25	42	78	QCMT050204	M2.0X5	T6
SF-12R-2.5D-C16	12	16	30	45	87	QCMT060204	M2.2X5	T6
SF-14R-2.5D-C16	14	16	35	45	92	QCMT070304	M2.5X6	T8
SF-16R-2.5D-C20	16	20	40	50	102	QCMT080304	M3.0X8	T10

3.5D

Многофункциональные сверла U-серии, 3.5D

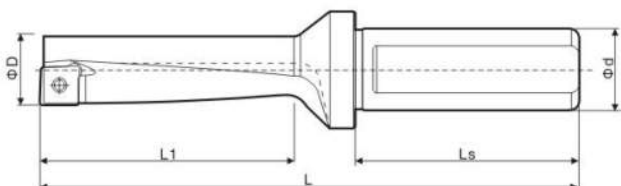

Обозначение	D	L1	L	Ds	Ls	Модель пластины	Винт	Ключ
SF-08R-3.5D-C16	8	16	28	42	80	QCMT040104	M1.8X4	T6
SF-10R-3.5D-C16	10	16	35	42	88	QCMT050204	M2.0X5	T6
SF-12R-3.5D-C16	12	16	42	45	98	QCMT060204	M2.2X5	T6
SF-14R-3.5D-C16	14	16	49	45	106	QCMT070304	M2.5X6	T8
SF-16R-3.5D-C20	16	20	56	50	118	QCMT080304	M3.0X8	T10

Корпусные сверла U-серии для обработки отверстий малых диаметров

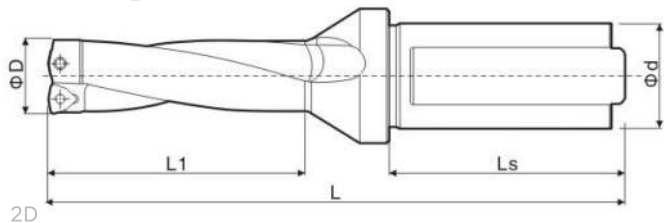

2D

Обозначение	D	L1	L	Ds	Ls	Модель пластины	Винт	Ключ
C20-2D10-22WC02	10	20	22	50	90	WC_020104	M1.8X4	T6
C20-2D10.5-23WC02	10.5		23		91			
C20-2D11-24WC02	11		24		92			
C20-2D11.5-25WC02	11.5		25		93			
C20-2D12-26WC02	12		26		94			
C20-2D12.5-27WC02	12.5		27		95			
C20-2D13-28WC02	13		28		-			
C20-2D13.5-29WC02	13.5		29		96			

2D

Обозначение	D	L1	L	Ds	Ls	Модель пластины	Винт	Ключ
C20-3D10-32WC02	10	20	32	50	101	WC_020104	M1.8X4	T6
C20-3D10.5-34WC02	10.5		34		103			
C20-3D11-35WC02	11		35		104			
C20-3D11.5-37WC02	11.5		37		106			
C20-3D12-38WC02	12		38		107			
C20-3D12.5-40WC02	12.5		40		109			
C20-3D13-41WC02	13		41		110			
C20-3D13.5-43WC02	13.5		43		112			

2D

Обозначение	D	L1	L	Ds	Ls	Модель пластины	Винт	Ключ
C20-4D10-42WC02	10	20	42	50	111	WC_020104	M1.8X4	T6
C20-4D10.5-44WC02	10.5		44		113			
C20-4D11-46WC02	11		46		115			
C20-4D11.5-48WC02	11.5		48		117			
C20-4D12-50WC02	12		50		119			
C20-4D12.5-52WC02	12.5		52		121			
C20-4D13-54WC02	13		54		123			
C20-4D13.5-56WC02	13.5		56		125			

Корпусные сверла U-серии для обработки отверстий малых диаметров

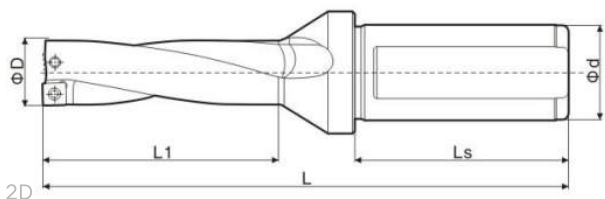

Обозначение	D	L1	L	Ds	Ls	Модель пластины	Винт	Ключ
C20-2D10-22SO04	10	20	22	50	90	SO_040102	M1.8X4	T6
C20-2D10.5-23SO04	10.5		23		91			
C20-2D11-24SO04	11		24		92			
C20-2D11.5-25SO04	11.5		25		93			
C20-2D12-26SO04	12		26		94			

2D

Обозначение	D	L1	L	Ds	Ls	Модель пластины	Винт	Ключ
C20-3D10-32SO04	10	20	32	50	101	SO_040102	M1.8X4	T6
C20-3D10.5-34SO04	10.5		34		103			
C20-3D11-35SO04	11		35		104			
C20-3D11.5-37SO04	11.5		37		106			
C20-3D12-38SO04	12		38		107			

2D

Обозначение	D	L1	L	Ds	Ls	Модель пластины	Винт	Ключ
C20-4D10-42SO04	10	20	42	50	111	SO_040102	M1.8X4	T6
C20-4D10.5-44SO04	10.5		44		113			
C20-4D11-46SO04	11		46		115			
C20-4D11.5-48SO04	11.5		48		117			
C20-4D12-50SO04	12		50		119			

5D

Удлиненные корпусные сверла с центрирующей сменной пластиной

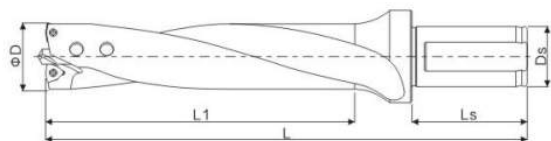

5D

Обозначение	D	L1	L	Ds	Ls	Модель пластины	Винт	Ключ
VLT-21050D S25	21	105	186	25	56	WCMX030208	M2.5X6	T8
VLT-22050D S25	22	110	191	25	56	WCMX030208	M2.5X6	T8
VLT-23050D S25	23	115	196	25	56	WCMX030208	M2.5X6	T8
VLT-24050D S25	24	120	201	25	56	WCMX030208	M2.5X6	T8
VLT-25050D S32	25	150	240	32	60	WCMX030208	M2.5X6	T8
VLT-26050D S32	26	150	240	32	60	WCMX040208	M2.5X7D4	T8
VLT-27050D S32	27	150	240	32	60	WCMX040208	M2.5X7D4	T8
VLT-28050D S32	28	150	240	32	60	WCMX040208	M2.5X7D4	T8
VLT-29050D S32	29	150	240	32	60	WCMX040208	M2.5X7D4	T8
VLT-30050D S32	30	150	240	32	60	WCMX040208	M2.5X7D4	T8
VLT-31050D S32	31	175	265	32	60	WCMX040208	M2.5X7D4	T8
VLT-32050D S32	32	175	265	32	60	WCMX050308	M3.0X8	T10
VLT-33050D S32	33	175	265	32	60	WCMX050308	M3.0X8	T10
VLT-34050D S32	34	175	265	32	60	WCMX050308	M3.0X8	T10
VLT-35050D S32	35	175	265	32	60	WCMX050308	M3.0X8	T10
VLT-36050D S32	36	200	290	32	60	WCMX050308	M3.0X8	T10
VLT-37050D S32	37	200	290	32	60	WCMX050308	M3.0X8	T10
VLT-38050D S32	38	200	290	32	60	WCMX050308	M3.0X8	T10
VLT-39050D S32	39	200	290	32	60	WCMX050308	M3.0X8	T10
VLT-40050D S32	40	200	290	32	60	WCMX050308	M3.0X8	T10

6.5D

Удлиненные корпусные сверла с центрирующей сменной пластиной

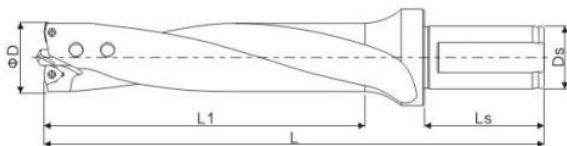

6.5D



Обозначение	D	L1	L	Ds	Ls	Модель пластины	Винт	Ключ
VLT-210650D S25	21	137	218	25	56	WCMX030208	M2.5X6	T8
VLT-220650D S25	22	143	224	25	56	WCMX030208	M2.5X6	T8
VLT-230650D S25	23	150	231	25	56	WCMX030208	M2.5X6	T8
VLT-240650D S25	24	156	237	25	56	WCMX030208	M2.5X6	T8
VLT-250650D S32	25	185	275	32	60	WCMX030208	M2.5X6	T8
VLT-260650D S32	26	185	275	32	60	WCMX040208	M2.5X7D4	T8
VLT-270650D S32	27	185	275	32	60	WCMX040208	M2.5X7D4	T8
VLT-280650D S32	28	185	275	32	60	WCMX040208	M2.5X7D4	T8
VLT-290650D S32	29	185	275	32	60	WCMX040208	M2.5X7D4	T8
VLT-300650D S32	30	185	275	32	60	WCMX040208	M2.5X7D4	T8
VLT-310650D S32	31	218	308	32	60	WCMX040208	M2.5X7D4	T8
VLT-320650D S32	32	218	308	32	60	WCMX050308	M3.0X8	T10
VLT-330650D S32	33	218	308	32	60	WCMX050308	M3.0X8	T10
VLT-340650D S32	34	218	308	32	60	WCMX050308	M3.0X8	T10
VLT-350650D S32	35	218	308	32	60	WCMX050308	M3.0X8	T10
VLT-360650D S32	36	250	340	32	60	WCMX050308	M3.0X8	T10
VLT-370650D S32	37	250	340	32	60	WCMX050308	M3.0X8	T10
VLT-380650D S32	38	250	340	32	60	WCMX050308	M3.0X8	T10
VLT-390650D S32	39	250	340	32	60	WCMX050308	M3.0X8	T10
VLT-400650D S32	40	250	340	32	60	WCMX050308	M3.0X8	T10

8D

Удлиненные корпусные сверла с центрирующей сменной пластиной

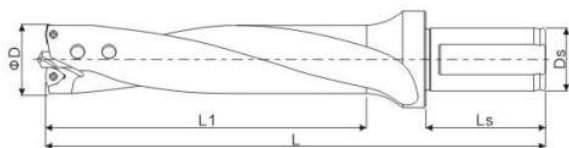

8D



Обозначение	D	L1	L	Ds	Ls	Модель пластины	Винт	Ключ
VLT-21080D S25	21	168	247	25	56	WCMX030208	M2.5X6	T8
VLT-22080D S25	22	176	255	25	56	WCMX030208	M2.5X6	T8
VLT-23080D S25	23	184	263	25	56	WCMX030208	M2.5X6	T8
VLT-24080D S25	24	192	271	25	56	WCMX030208	M2.5X6	T8
VLT-25080D S32	25	220	310	32	60	WCMX030208	M2.5X6	T8
VLT-26080D S32	26	220	310	32	60	WCMX040208	M2.5X7D4	T8
VLT-27080D S32	27	220	310	32	60	WCMX040208	M2.5X7D4	T8
VLT-28080D S32	28	220	310	32	60	WCMX040208	M2.5X7D4	T8
VLT-29080D S32	29	220	310	32	60	WCMX040208	M2.5X7D4	T8
VLT-30080D S32	30	220	310	32	60	WCMX040208	M2.5X7D4	T8
VLT-31080D S32	31	260	350	32	60	WCMX040208	M2.5X7D4	T8
VLT-32080D S32	32	260	350	32	60	WCMX050308	M3.0X8	T10
VLT-33080D S32	33	260	350	32	60	WCMX050308	M3.0X8	T10
VLT-34080D S32	34	260	350	32	60	WCMX050308	M3.0X8	T10
VLT-35080D S32	35	260	350	32	60	WCMX050308	M3.0X8	T10
VLT-36080D S32	36	300	390	32	60	WCMX050308	M3.0X8	T10
VLT-37080D S32	37	300	390	32	60	WCMX050308	M3.0X8	T10
VLT-38080D S32	38	300	390	32	60	WCMX050308	M3.0X8	T10
VLT-39080D S32	39	300	390	32	60	WCMX050308	M3.0X8	T10
VLT-40080D S32	40	300	390	32	60	WCMX050308	M3.0X8	T10

Быстросменные головки

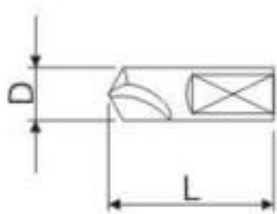

Обозначение	D	L	Подходящий тип сверла
PLD-V0630 TIN	6	30	VLT, TSD, TMD
PLD-V0835 TIN	8	35	VLT, TSD, TMD
PLD-V1035 TIN-H	10	35	VMD, VLT, MXD, TSD, TMD
PLD-V1238 TIN-H	12	38	VMD, VLT, MXD, TSD, TMD
PLD-V1645 TIN-H	16	45	VMD, VLT, MXD, TSD, TMD
PLD-2045 TIN-H	20	45	VMD, MXD
PLD-2558 TIN-H	25	56	VMD, MXD
PLD-3068 TIN-H	30	68	VMD, MXD



| www.rinscom.com
| Брянск, ул. Воровского, д. 6
| Москва, ул. Артюхиной, д. 4

| all@rinscom.com
| 8 (800) 200-48-32

